



**National Library
of Canada**

**Acquisitions and
Bibliographic Services**

**395 Wellington Street
Ottawa ON K1A 0N4
Canada**

**Bibliothèque nationale
du Canada**

**Acquisitions et
services bibliographiques**

**395, rue Wellington
Ottawa ON K1A 0N4
Canada**

Your file Votre référence

Our file Notre référence

The author has granted a non-exclusive licence allowing the National Library of Canada to reproduce, loan, distribute or sell copies of this thesis in microform, paper or electronic formats.

The author retains ownership of the copyright in this thesis. Neither the thesis nor substantial extracts from it may be printed or otherwise reproduced without the author's permission.

L'auteur a accordé une licence non exclusive permettant à la Bibliothèque nationale du Canada de reproduire, prêter, distribuer ou vendre des copies de cette thèse sous la forme de microfiche/film, de reproduction sur papier ou sur format électronique.

L'auteur conserve la propriété du droit d'auteur qui protège cette thèse. Ni la thèse ni des extraits substantiels de celle-ci ne doivent être imprimés ou autrement reproduits sans son autorisation.

0-612-33804-5

**Tactical Air Power in the Normandy Campaign:
The Role of 83 Group**

by

Christopher Robert Evans

**Combined Honours B.A. English and History, Carleton University, 1991
B.A. Political Science, Carleton University, 1993**

THESIS

**Submitted to the Department/Faculty of History
in partial fulfilment of the requirements for
Master of Arts**

Wilfrid Laurier University

1998

Christopher Robert Evans 1998©

ABSTRACT

There is now over a half century of historiography regarding tactical air power in the Normandy campaign in the Second World War. Within this body of material there exists two schools of thought; by far the largest and most popular is that which argues tactical air power was effective, even decisive, in winning the campaign, primarily in the role of 'tank-buster'. A more moderate school has attempted to refute this and instead argue that tactical air power, while effective, was not decisive, and contributed to the campaign by producing a negative 'morale effect' on the enemy. In each case the focus has been on the provision of air support directly on the battlefield.

This thesis studies the role of 83 Group and its effectiveness in providing support to the land campaign using a broader perspective that incorporates the study of tactical air power both above and beyond the field of battle. It also addresses the assumptions ingrained in the historiography and offers a new, balanced appraisal of tactical air power in Normandy and in the Second World War.

Acknowledgments

This thesis is based upon documents from the Public Record Office in the United Kingdom, the Directorate of History and Heritage, Department of National Defence, Ottawa and the United States Air Force Archives, Montgomery, Alabama. Some of the British and American documents are part of the collection of the Laurier Centre for Military Strategic and Disarmament Studies and were donated by Professor Terry Copp and Dr. Robert Vogel (now deceased) who had originally planned to write a book on tactical air power. Their research was assisted by a grant from the Social Science and Humanities Research Council, Wilfrid Laurier University and McGill University. Mr. Oliver Haller undertook a good deal of the research in locating many of the documents in the United Kingdom for the initial project. In addition I conducted a research trip to the Imperial War Museum and Public Record Office utilizing its massive documents collection.

No work of this magnitude is done in isolation and I would like to thank the people who have assisted me in this endeavour. Through the support of the Canadian Battle of Normandy Foundation I had the great fortune to travel to Europe and study the battlefields of Normandy. My guide at the time, Professor Terry Copp, soon after

became my advisor and encouraged me to continue the work begun by himself and Robert Vogel. Not unlike a new pilot being schooled in the ways of the squadron by its leader, Professor Copp allowed me to stretch my wings and explore new avenues of research, but was there to clip them whenever I threatened to spin out of control down some fascinating but secondary avenue. His guidance and forbearance were of immense value and by his own example Professor Copp renewed my faith that the study of our past experiences in warfare are intrinsic to the study of history and can not and should not be divided.

Many others also assisted me along the way and deserve acknowledgment: The staff at the Imperial War Museum and Public Record Office in London, Directorate of History in Ottawa and RCAF Museum in Trenton who provided friendly, helpful assistance; Dr. Norman Hillmer, Dr. George Urbaniak and Professor Syd Wise who, as former teachers, encouraged me in my work and inspired me by their own; Dr. John Last, MD, FRCPC, who gave me sage advice at a pivotal juncture in my earlier studies; Mrs. Lynne Doyle of the history department and the staff of Graduate Studies whose assistance in navigating the intricacies of university rules and regulations was invaluable; Michael Evans, Jamie Leggo and Randy Lutz who bolstered my conviction that, just as military history should not be separated from history, man and the machines he uses in warfare are just as strongly related; Mike Bechthold, Stephen Duncan, Serge Durflinger, Alan Thurrot and Brian Rawding who, as young historians themselves, provided a great sounding board and more than a few laughs when I needed them.

And finally, I wish to thank my parents who have given me unconditional love and support throughout my life and make each of my accomplishments the greater because of it. It is to them that I dedicate this work.

Despite the length of the list of those who helped me, all errors and omissions are the responsibility of the author alone.

Christopher Evans
September 1, 1998
Kitchener, Canada

Table of Contents

Abstract	i
Acknowledgments	ii
Table of Contents	v
List of Tables	vi
List of Figures	vii
Introduction	1
Chapter One	14
Chapter Two	47
Chapter Three	74
Conclusion	124
Appendices	
Appendix A - 83 Group Organization Chart	138
Appendix B - Summary of 83 Group Claims	139
Appendix C - German Anti-Aircraft Guns	141
Appendix D - Gun Armament Chart of 83 Group Aircraft	142
Appendix E - Three Main Fighter Types of 83 Group	143
Bibliography	144

Tables

Table

- 1.1 Number of Bombs to Give an Even Chance of Hitting a Standard Point Target of Area 150 sq. ft.
- 2.1 German Fighter Losses - June 1944 Western Front
- 3.1 Estimate of Luftwaffe Reinforcements to reach Normandy
- 3.2 Production of Air Photographs by 83 Group during the Normandy Campaign
- 3.3 Typhoon Casualties Against all Targets
- 3.4 Typhoon Casualties due to Flak
- 3.5 Summary of Vehicles Found and Investigated at La Baleine
- 3.6 Results of Ground Investigation at Mortain
- 3.7 Analysis of Damage by Air Attack to Enemy Equipment During the Pocket Period
- 3.8 Enemy Vehicles Found in the 'Shambles', August 1944
- 3.9 Enemy Vehicles Found in the 'Chase', August 1944
- 4.1 Effort expended on obtaining and maintaining Air Supremacy
- 4.2 Sorties by Aircraft of 2 ATF during the Normandy Campaign
- 4.3 Attacks by Fighters and Fighter Bombers on Gun Positions, HQs etc. which were checked by ground observers afterwards

Figures

Fig.	
1	Rocket-Firing Typhoons at the Falaise Gap, Normandy, 1944
2	“Watch me sink the next one into the right pocket.”
3	“Boys, meet Mr. Jones. He flies a Rocket-Typhoon.”
1.1	Side View of Strafing Attack
1.2	Side View of Rocket Projectile Attack
1.3	Side View of Dive Bombing Attack
1.4	Rocket Installation
1.5	Army Air Training Instruction Pamphlet
3.1	The Normandy Campaign
3.2	Fighter Patrol Areas on June 6, 1944
3.3	Enemy Vehicles Found in ‘The Pocket’, August 1944
3.4	Map of Enemy Vehicles Found in the ‘Shambles’, August 1944
3.5	Map of Enemy Vehicles Found in the ‘Chase’, August 1944

Introduction

The primary purpose of this thesis is to examine the role played by 83 Group of the Royal Air Force's 2nd Tactical Air Force in the Battle of Normandy, 6 June to 21 August, 1944. To accomplish this purpose it has proven necessary to investigate the development of tactical air doctrine in the RAF and to evaluate equipment-procurement/development decisions made in the pre-invasion period. The thesis therefore makes a contribution to our understanding of the broader history of tactical air power in the Second World War.

Two very different schools of thought exist regarding the effectiveness of tactical air power, and its role in the Normandy campaign. The Royal Air Force, its proponents and certainly its pilots, argued strongly and persuasively that their contribution had been vital in the victory, perhaps even decisive. Individual pilots wrote memoirs filled with bravado and recounted such heroic acts that their compelling tales swept the day, solidifying the image of the tank killing fighter aircraft as depicted in Frank Wootton's painting 'Rocket-firing Typhoons at the Falaise Gap,

Normandy, 1944'.¹ Even cartoons of the time made it clear just how effective these 'tankbusters' were.² (Fig. 1, 2 & 3)

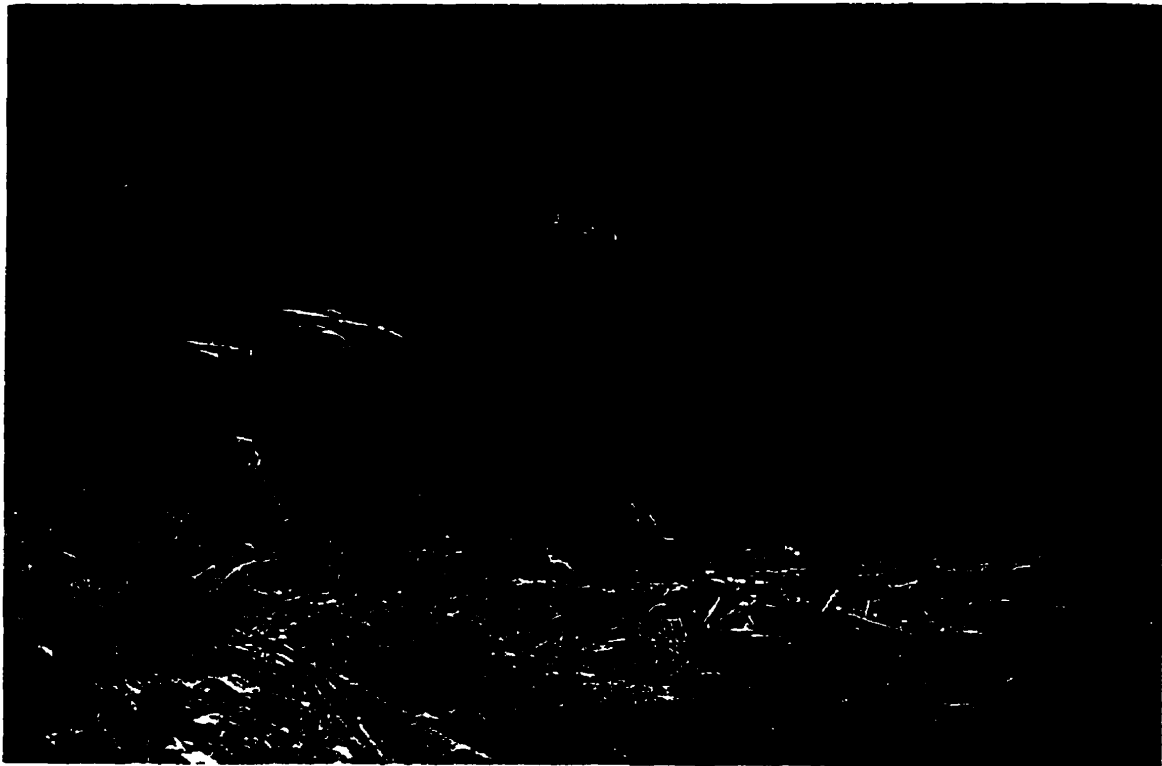

"Watch me sink the next one into the right pocket."
Ricki REAF
FRANCE



"Boys, meet Mr. Jones. He flies a Rocket-Typhoon."
Ricki &
MOLLA

Dashing heroes abounded and publishers were eager to provide the public with their tales of daring do. Group Captain Desmond Scott, a former Typhoon pilot, echoed many when he wrote

if a self propelled gun in a certain grid number was giving trouble we would immediately streak down and blow it to pieces. Tanks, guns, mortar positions and troop concentrations were attacked in this manner, some very close to our own troops. It was the ultimate in close-support operations.³

His and so many other pilots' claims of destruction were bolstered immensely from on high. The commanding officer of the 2nd Tactical Air Force, Air Marshal Sir Arthur Coningham, in his report on operations released after the war stated clearly in bold lettering that tactical air power had been "decisive" on more than one occasion in winning the field of battle.⁴ Coningham's knighthood along with his many other decorations seemed further proof that what the flyboys said must be right.

The pervasiveness of this idea is very strong and appears in memoirs of other combatants as well. George C. Blackburn, a former gunner with the Canadian artillery wrote in his award winning, national best seller The Guns of Normandy, published in 1995, that:

Surely the Typhoon is proving to be the most effective weapon of all in combatting the superiority of the enemy's armour, particularly his irresistible Tigers. Without the Typhoons, the Allies might never have subdued his armoured divisions to the point where a break-out became possible.⁵

Along with the wide readership one expects from a best seller and award winning book The Guns of Normandy has been praised as the finest "first hand account of Canadians at war" that "promises to be definitive about wartime soldiering" and that "may well contain the greatest Canadian memoirs of World War II."⁶ Surely then this idea must

be right? One must keep in mind however, that the victors write the history and their version may not necessarily be the most accurate. That said, the defeated, the Germans, wholeheartedly supported the tales of tactical air power, a battle and even war-winning factor.⁷ Less than one week into the campaign Field Marshal Erwin Rommel, the general specifically tasked with repelling the invasion forces, despaired that this would prove impossible:

Our own operations are rendered extraordinarily difficult and in part impossible to carry out [owing to] the exceptionally strong and, in some respects overwhelming, superiority of the enemy air force. The enemy has complete command of the air over the battle zone and up to about 100 kilometres behind the front and cuts off by day almost all traffic on roads [-] Neither our flak nor the Luftwaffe seem capable of putting a stop to this crippling and destructive operation of the enemy's aircraft.⁸

Almost as if fate dictated it, Rommel was seriously injured a month later when his staff car was strafed by fighters of the 2nd Tactical Air Force.

A study produced by the German Air Historical Branch in August of 1944 considered allied air power the “decisive factor in the launching of the invasion” and chronicled the many difficulties the Germans were enduring because of it. It stated that it was vital “to fight the fighter-bombers [-] as these endanger the reinforcements and communications of the Army.”⁹ However the study was not able to offer a positive solution.

After the war historians weighed in with their own take on the matter. When they did, they voted overwhelmingly in favour of tactical air power. Chester Wilmot's The Struggle for Europe and John Terraine's The Right of the Line claimed that “air power was the decisive factor in the Normandy campaign.”¹⁰ Resident historian

Brereton Greenhous, of the Canadian National Defence Directorate of History, concluded much the same. He was careful to note however, in a 1975 presentation at the International Conference on Military History held in Washington, D.C., that “Airmen - and sometimes, perhaps, air historians! have tended to attribute too high a proportion of armour destroyed in battle to airpower’s own unaided efforts” and suggested dividing all claims by three as a good starting point.¹¹ Nonetheless, the use of tactical air power was still considered highly effective. A Historical Analysis of the Effectiveness of Tactical Air Operations Against, and in Support of, Armored Forces was published five years later and claimed to “substantiate the view of many experts that this aircraft [Typhoon] was the most effective antitank plane in World War II.”¹² As the data used was almost exclusively based on pilot claims however, the validity of this scientific approach is suspect.

However the historians said it, it is Hollywood that has forever immortalized the tank killing prowess of tactical aircraft on film with the hit movie “Saving Private Ryan”.¹³ With the likes of former pilots, their commanding officers, eminent historians and Hollywood to support the claim, the debate on the effectiveness of tactical air power in Normandy seems moot. Struggling to be heard amid this cacophony of praise however, has remained a persistent if quiet voice that questions the entire notion of ‘The Day of the Typhoon’.¹⁴

Couched under the mundane title ‘Operational Research’ and studied by a small but dedicated group of scientists, the effectiveness of tactical air power was carefully tabulated, charted, cross referenced and analyzed during and after the war. As

opposed to books with wildly evocative names like The Big Show, Blue Skies, Typhoon Attack or Firebirds: Flying the Typhoon in Action, the men of the obscure operational research teams produced papers with uninspired if functional titles such as ‘Report No. 41 - Operational Rocket Projectile Tactics’ or ‘Operational Results from the Gyro-Gunsight Assessment of Films, 15th June - 7th July, 1944’.¹⁵ Then again, the reports of the operational researchers were not designed to ‘sell copies’ but to inform senior leadership of the performance of weapons on the battlefield so that effectiveness could be ascertained and improvements instigated. However, Air Vice-Marshal Johnnie Johnson, 2nd Tactical Air Force’s highest scoring ace, questions even the effectiveness of that in his book Courage in the Skies. Johnson recounts that after the success of halting the German attack at Mortain on August 7, 1944, at the time attributed almost solely to the Typhoon squadrons of Air Marshal Harry Broadhurst’s 83 Composite Group, he commented that

we had received a report from Solly Zuckerman [Scientific Adviser to the Allied Expeditionary Air Force Bombing Committee] stating that our sixty-pound rockets were pretty useless against tanks!¹⁶

The exclamation mark was an indication of Broadhurst’s disbelief as his pilots claimed a staggering 82 tanks destroyed and another 47 damaged in just one day. It is clear whom he believed.¹⁷ Nonetheless, the scientists continued with their work, using empirical data quantified into reports with charts and graphs illustrating their conclusions in a sound and reasoned manner. Time after time what they found indicated that tactical air power and specifically ‘tank-busters’ couldn’t hit the broadside of barn door...with a barn door. In short, despite what the pilots were

saying, 'The Day of the Typhoon' was a myth and tactical air power was a fraud; the support the army wanted so desperately on the battlefield was a mirage...or was it?

In light of the overwhelming support for tactical air power as a tank destroyer and winner of battles it is not surprising that it took almost four decades for the first signs of a serious rebuttal to be mounted that reintroduced the findings of the Operational Research teams all those years ago. Historian W.A. Jacobs began with an article in the early 1980's that culminated in a chapter in Case Studies in the Development of Close Air Support published in 1990. Utilizing the wealth of O.R. material Jacobs sought to redress the imbalance and suggested that tactical air power played a 'significant role'.¹⁸ This idea was strengthened by Terry Copp and Robert Vogel who, working together, gave strength to Jacobs' argument that tactical air power had not done all that had been claimed for it.¹⁹ The momentum grew, albeit in a more stately and somber fashion than the dominant school of thought, with an article in the early 1990's that convincingly 'debunked' the tank killing prowess of tactical air power.²⁰ It was written by then graduate student Ian Gooderson, who soon added to his work and produced the first serious and in depth look at tactical air power using O.R. material entitled Air Power at the Battlefield: Allied Close Air Support in Europe, 1943 - 1945 from his doctoral dissertation.²¹ Gooderson clearly argues that the notion of tank killing fighter-bombers is a myth. In its place he claimed the real contribution made by tactical air power on the battlefield was the 'morale effect.'²² Put simply, even if the fighter-bomber couldn't destroy a tank or pill box, it could and did terrify the soldiers within thereby degrading their ability to fight. In this way, tactical air power now

stands resurrected as an effective battlefield tool that made its presence felt in a more abstract yet still meaningful way. But is this really the case? After having rejected the claims of pilots and instead relied on hard statistical data it seems incongruous to now argue something almost impossible to quantify that the O.R scientists struggled vainly with over fifty years before.

In fact, the historiography for the past half century has focused so tightly on one aspect of tactical air power, close air support, that it has missed almost completely the bigger picture. The argument of this thesis is that the **defensive** and **protective** nature of tactical air power, not ‘tank-busting’ or ‘morale effects’, was the major contribution of 83 Group. Furthermore, the limitations of the aircraft and pilots that flew them dictated that an operational doctrine would reflect this.

This thesis begins at the beginning with an attempt to understand the evolution of ideas about tactical air power and the reasons for the RAF’s decision to respond to army demands by converting the single-engined, liquid cooled aircraft of Fighter Command to a ground support role. The thesis argues that this decision, while understandable in terms of the task assigned to the RAF, seriously limited the ability of tactical air power to respond directly to the needs of the ground forces. The dichotomy of views between the RAF and the army are also examined shedding light on two very disparate notions of what tactical air power was and how it should be used.

Chapter Two examines the consequences of the decision to use single engine fighters as the primary tactical aircraft and its impact on doctrine and tactics during the

months before D-Day when 83 Group was learning how to carry out its ground support role. The thesis argues that both the heavy casualties and the reports prepared by RAF operational research teams demonstrated that serious problems in target location, accuracy of weapons and survivability against anti-aircraft fire were known to exist when fighter-bombers were used in a ground support role. While aware of the problems, the RAF had little choice except to deploy these squadrons. Their method of employment was designed to minimize the limitations of the fighter-bombers without seriously hindering their ability to support the army on the continent. They could not, however, support the ground forces in the way the army wanted.

Chapter Three offers an account of the operations carried out by 83 Group during the Normandy campaign and demonstrates that 83 Group concentrated its efforts on air superiority, armed reconnaissance/interdiction and intelligence gathering because of the many difficulties in providing direct or close support, and because they believed it was the superior doctrine.

The conclusion to the thesis reflects upon these problems and offers a balanced assessment of the role of 83 Group in the Normandy campaign. Only by studying the broader role of tactical air power can a true estimate of the effectiveness of tactical air power be made. This thesis offers a new and more complete understanding of the role played by fighter aircraft from D-Day to the closing of the Falaise Gap.

The ramifications of this research however, affects far more than our understanding of Normandy and the Second World War. The current trend in military operations conducted by first world nations and indeed, the United Nations, has been to rely

extensively, even exclusively, on tactical air power. A detailed and clearer understanding of the historical role played by tactical air power therefore has obvious benefits to air forces that trace their lineage, assumptions, traditions and doctrine to operations conducted a half century ago above the fields of Normandy.

End Notes to Introduction

¹ Wootton's painting is featured on the cover of Courage in the Skies: Great Air Battles from the Somme to Desert Storm written by two former fighter aces, J.E. 'Johnnie' Johnson and P.B. 'Laddie' Lucas. It also appears in the Official History of the Canadian Army in the Second World War, Volume III and the British official history Victory in the West. In a similar fashion, Christopher Shores used a propaganda photograph featuring a destroyed German tank, upturned half track and several rifles with German helmets on them stuck in the ground as a symbolic illustration of what tactical air power accomplished in his book 2nd Tactical Air Force, 1970. Many books have used similar imagery to that of Wootton's painting and feature renderings of their own that show Typhoon's in a most positive light. See John Golley's The Day of the Typhoon: Flying with the RAF Tankbusters in Normandy, Hugh Halliday's Typhoon and Tempest: The Canadian Story, Jerry Scutts' Typhoon/Tempest in Action and Richard Townshend Bickers' Air War Normandy.

² "Boys, meet Mr. Jones. He flies a Rocket-Typhoon." in Typhoon and Tempest at War by Arthur Reed and Roland Beamont, 1974, p 93. "Watch me sink the next one into the right pocket." In Typhoon and Tempest: The Canadian Story by Hugh Halliday, 1992, p 66. The cartoons were first published during the war in Canadian army newspapers.

³ Desmond Scott. Typhoon Pilot. London: Arrow Books, 1982, p 119.

⁴ AIR 37/876 Air Marshal Arthur Coningham. Operations Carried Out by Second Tactical Air Force Between 6th June 1944 and 9th May 1945. November, 1945, pp. 10 - 12.

⁵ Blackburn, George C. The Guns of Normandy: A Soldier's Eye View, France 1944. p 350.

⁶ Reviews by Tom Clark, National Editor, BBS-TV, Toronto Sun, and Trillium Award jury citation as cited on dust cover of The Guns of Normandy.

⁷ See the United States Department of the Army: Historical Section: O.B. West: "Atlantic Wall to Siegfried Line - A Study in Command" comprised of 5 volumes with many German generals contributing to it, written between 1946 to 1948. Volume I Chapter I is entitled "The Decisive Influence of Enemy Air Power" and speaks for itself.

⁸ John Terraine. Right of the Line: The Royal Air Force in the European War, 1939 - 1945, p 637 Message from Rommel to Field Marshal Keitel, June 12, 1944.

⁹ German Air Historical Branch 'The Normandy Invasion - June, 1944' August 6, 1944. Translated by the British Air Ministry, June 23, 1947, p 7.

¹⁰ Chester Wilmot. The Struggle for Europe. p 289. See also John Terraine. The Right of the Line: The Royal Air Force in the European War, 1939 - 1945. p 284.

¹¹ Brereton Greenhous. 'Mythology, Technology and Aircraft in an Anti-Armour Role Before 1945' presented at the International Conference on Military History, Washington D.C., 14 - 19 August, 1975, p 13. See also his unpublished paper 'The Effectiveness of Aircraft v. Armor in the Battle of Normandy, 1944' in which he concludes in "the first month of the Normandy campaign the use of aircraft in a close support role against armor may well have been decisive", p 20.

¹² Historical Evaluation and Research Organization (Sandia National Laboratories). A Historical Analysis of the Effectiveness of Tactical Air Operations Against, and in Support of Armored Forces, October 1980, p 57.

¹³ In his most recent big budget movie, 'Saving Private Ryan', summer - 1998, director Steven Spielberg relates a tale of courage and sacrifice in the Normandy campaign aided by stunning special effects and a seeming sense of realism other war movies have never been able to capture. At the very climax of the movie when all seems lost two aircraft, Mustangs in this case as it is an American tale, swoop down from a clear blue sky and with an accuracy to rival pilots of the Gulf War with smart weapons, destroy a dreaded Tiger tank and in so doing save the day... and Private Ryan.

¹⁴ See Richard P. Hallion's Strike from the Sky: The History of Battlefield Air Attack, 1911 - 1945. Shrewsbury, 1989 and by the same author D-Day 1944: Air Power over the Beaches and Beyond. Air Force History and Museum Program, 1994. The phrase refers to the successful destruction of the German armoured attack at Mortain on August 7, 1944 in which rocket firing Typhoons have been credited with the victory. Credence to this claim was added by the Allied Supreme Commander, General Dwight D. Eisenhower, who said "The chief credit in smashing the enemy's spearhead, however, must go to the rocket firing Typhoon planes of the Second Tactical Air Force" p 217 and p 33. Along the same lines 2nd Tactical Air Force, by Christopher Shores claimed that the Typhoons "saved the day" p 18.

¹⁵ See Pierre Clostermann's The Big Show: Some Experiences of a French Fighter Pilot in the RAF. London, 1951; Bill Olmsted's Blue Skies: The Autobiography of a Canadian Spitfire Pilot in World War II. Toronto, 1987; Norman Frank's Typhoon Attack, London, 1984; Charles Demoulin's Firebirds: Flying the Typhoon in Action. Shrewsbury, 1986/87; Report No. 41 - Operational Rocket Projectile Tactics, ORS (Air Defense Great Britain) March 30, 1944. AIR 37/497 xc155046; and 'Operational Results from the Gyro-Gunsight Assessment of Films, 15th June - 7th July, 1944' ORS (Allied Expeditionary Air Force) August 26, 1944. AIR 37/497 xc155046

¹⁶ Johnnie Johnson and Laddie Lucas. Courage in the Skies: Great Air Battles from the Somme to Desert Storm, London, 1992, p 140.

¹⁷ 83 Group Intelligence Summary for August 1944. See papers of Squadron Leader R. T. Wilkins, Imperial War Museum 83/15/3

¹⁸ W.A. Jacobs. 'The Battle for France in Case Studies in the Development of Close Air Support, p 284.

¹⁹ See 'Anglo-Canadian Tactical Air Power in Normandy: A Reassessment' 1987 presentation at the American Military Institute, Virginia, by Terry Copp and Robert Vogel; 'Tactical Air Power in Northwest Europe 1944-45: The Evidence from Operational Research' 1987 Draft paper by Terry Copp; 'Tactical Air Power in Normandy: Some Thoughts on the Interdiction Plan' in *Canadian Military History*, Spring 1994, Vol. 3, No. 1 by Robert Vogel.

²⁰ Ian Gooderson 'Allied Fighter-Bombers Versus German Armour in North West Europe 1944-1945: Myths and Realities' in *The Journal of Strategic Studies*, Volume 14, June 1991, No. 2, pp 210 - 231.

²¹ Ian Gooderson. Air Power at the Battlefield: Allied Close Support in Europe 1943-45. London, 1998.

²² Gooderson. *Ibid.* See Chapter 8.

Chapter One

At the start of the First World War military heavier than air aviation consisted of simple cloth and string machines capable of short duration flights at low altitude. Unarmed, they were used as little more than mobile observation platforms. Four years later aircraft capable of carrying machine guns and several bombs, were able to travel at previously unimagined speeds for great distances and at heights that required the wearing of oxygen masks. Compared with the attrition of trench warfare the air war, while costly, appeared to offer an easier way to wage, and possibly win, war. The concept of strategic bombing began to take shape, the idea being that large multi-engined bombers could deliver massive bomb loads far behind the enemy's front lines disrupting the work of its factories and directly attacking the morale of its citizens. The bombing of London by Zeppelins created a furor in England and public opinion demanded retaliation in kind. Strategic bombing against Germany thus began in the spring of 1917. While initially converted fighters and small bombers were used, by the end of the war specially built heavy bombers such as the Handley Page O/100 were employed which would have been followed by the even more powerful V/1500 had the war continued.¹

By 1917 the Royal Flying Corps began to study the possibility of assisting the ground forces with more than aerial reconnaissance and artillery spotting. Sir Douglas Haig argued strongly for all available aircraft to assist directly in the fighting at Passchendaele in 1917 but no purpose-built aircraft existed that could adequately meet the demand. In April 1918 the newly independent Royal Air Force (RAF) asked for

two new fighters, one for aerial combat and one for ground attack, under the specifications AF Type I and AF Type II. The Type I would eventually become the Sopwith Snipe and reached squadrons in September 1918. The Type II was designated the Salamander and it was specifically designed to address the need for a close air support aircraft. To survive above the battlefield the cockpit area was protected by 8mm of armour, a trade off of speed for protection. The two forward firing Vickers machine guns were set at a depressed angle below the line of flight to better allow for strafing. This meant the pilot had less chance of flying into the ground while attacking a target but resulted in a decreased ability to hit air targets. In other words, the Salamander had one role and one role only, ground attack.²

These modifications had first been tried out in converted Camels which were sent to France for evaluation.³ Other attempts included the FE2 Bristol fighter equipped with small bomb racks on its lower wings.⁴ Despite promising reports, the war was over before these aircraft or the Salamander could demonstrate their potential. With the massive down sizing of the military after the war and the growing enthusiasm for heavy bombers with their promise of obviating the need for future ground wars, development of ground attack-aircraft all but ceased.

The concept of strategic bombing continued to gain popularity during the interwar period, championed by Italian General, Giulio Douhet and American General, William Mitchell. No government was keen to fight another land war of attrition and the idea that the heavy bomber could prevent this by taking the war right to the heart of the enemy country made it the main focus of many air forces at this time, including that of Britain. As one historian has noted:

On the basis of the evidence of the Great War, the airmen argued that any future warfare on land or at sea would be doomed to a stalemated battle of attrition; the strength of modern defensive technology had made a breakthrough virtually impossible. Future warfare should therefore develop on the principle that victory could be won by leaping over the enemy armed forces and attacking the centres of industry and of civilian morale on which the fighting fronts ultimately depended.⁵

As a result, aircraft designed to support land operations were neglected and it wasn't until 1927 that the Armstrong Whitworth Atlas, the first aircraft specifically built for such a task since the Sopwith Salamander of 1918, entered service. A fabric skinned two seat biplane, the Atlas was far from ideal. The Atlas was unarmoured and functioned for the most part as an observation platform. By December 1934 it had a rather odd stablemate in the form of the Cierva C.30 Autogiro, a combination helicopter/aircraft, with six being delivered to the School of Army Cooperation.⁶ The reason for such meager additions was not hard to find.

A 1924 RAF Air Staff Planning Committee meeting had made it clear that the development of dedicated attack aviation, as was occurring in the United States, was "quite unsuited to the needs of this country and that it would be impossible to produce a similar organization without starving far more important branches of the RAF."⁷ The more important branches were those concerned with the development of long range strategic bombers and short range defensive fighters to defend against enemy bombers. While beyond the scope of this paper a cursory examination of British foreign policy between the wars makes the reason for this abundantly clear. British policy focused on not tying itself to a large commitment of land forces on the continent ever again. The Royal Air Force would therefore not be required to support

a land army on a large scale and so could focus instead on the bomber and defenses against it.

In comparing policy in America and Italy with developments in Britain a 1935 report noted that “an air force whose primary function is direct co-operation with the Army in a large scale ‘land-forces’ war - [was] neither in the role of the Royal Air Force in war, nor in its ‘imperial police’ duties in normal times.”⁸ It was clear that an independent RAF had no intention of reverting to an army support role. However, hedging their bets ever so slightly the report’s authors conceded that some gesture must be made:

It is recommended that, although it may not be considered necessary or desirable to form an experimental attack squadron, some direction is necessary as to the importance to be attached to the occasional employment of a proportion of squadrons on low flying attacks and the consequent regard to be paid to this requirement in training schemes, tactical exercises and development of equipment.⁹

That this was just a gesture is made clear by another statement in the report, “the idea of armouring aircraft for use in the RAF has been definitely abandoned and, although it is probable that extensive use will be made of low flying attacks against ground targets in the future, the ordinary service types of machines will be used for this work.”¹⁰

Two decades after the First World War RAF development of ground attack aircraft and doctrine was stagnant.

Group Captain John Slessor was one of the few senior air staff personnel interested in the problems of close air support. But in his book Air Power and Armies, published in 1936, he echoed the feelings of the RAF in general that the air force would not participate in a land battle except under the most extreme conditions.¹¹ An Air Staff

paper published in November 1939 and known as the Slessor Memorandum reaffirmed his earlier work, “decrying the use of tactical close support.”¹² It is therefore not surprising that the RAF began the Second World War with the Westland Lysander, designed for reconnaissance and artillery spotting, dedicated to direct army support. Slow, unarmoured and lightly armed, the Lysander epitomized the RAF’s view of the role of air support for the army on the battlefield.¹³

By the summer of 1940, with the British Expeditionary Force (BEF) swept from the field of battle in France, the RAF and Royal Navy were left to take the fight to Germany, and only the RAF had the potential to really do so. In the face of continued German success and the growing reputation of the Stuka dive bomber in ground support roles a new school of thought, one that was at odds with the RAF’s main strategic initiative, was coalescing. After trials conducted in Northern Ireland in September 1940 Colonel J.D. Woodall and Group Captain A. Wann produced a report which put forth the then heretical notion of close air support including the creation of ‘tentacles’. Their proposal was that army officers in light cars would be placed with front line units and from this forward position they would signal back requests for air support “directly to a control centre, where they were monitored by Army and Air Force Staff Officers, sitting together.”¹⁴ The ramifications were twofold; the aircraft would provide close support to the battlefield and two, the dedicated signals apparatus/procedure to control such support, later known as Army Support Signals Units (ASSU) would be established. However, acceptance of this new doctrine would take years of bitter inter-service fighting as well as trial and error in North

Africa and Italy before any real attempt was made to incorporate it into the plans for a return to the European mainland.*

By the end of 1940 the lip service paid to army support by the RAF was no longer enough. Therefore, on December 1, 1940 Army Cooperation Command was created under Air Marshal Sir Arthur Barratt in England. Coming as it did after the post mortem on Dunkirk it presented an opportunity for the Army and Air Force to work together for future operations. Despite the hopeful title ACC was made up of just two groups, one equipped with 12 squadrons of Lysanders, the other with an administrative and training function. However, events were taking place that would force the RAF to re-examine its policies on ground support.

The launching of Operation Barbarossa in the summer of 1941 saw the Luftwaffe transfer almost all of its available fighter squadrons to the east. As a result the Luftwaffe was no longer a major threat to England which meant the defensive role of Fighter Command with its squadrons of high performance single engine fighters was suddenly excessive. In fact, the RAF was the only service that had the ability to take the offensive to the Germans and this factor was to prove crucial in advancing the concepts of army air support. In an attempt to assist their newly found Russian allies

* John Terraine argued in The Right of the Line that by 1940-41 the three essential elements of close air support began to take shape in both England and the Middle East. As he defined them they were the need for close working relationships between air and ground officers, a dedicated signals apparatus to relay information and the mutual understanding that at times the Air Force must be prepared en masse to cooperate with the Army and therefore foregoing, at least for a time, its desired independent role of winning the war through strategic bombing. While it is true that all three criteria were being developed at this time RAF acceptance was grudging and progress, especially in England where 2 TAF was to emerge, was slow. (See Terraine, Right of the Line, p 352).

the British employed the only offensive tool they had in Europe, the RAF. This support took the form of bombing and fighter sweeps over occupied Europe, under a variety of code names and configurations, all with the basic intent of drawing Luftwaffe reserves to the west and keeping enough pressure on those still stationed there that they could not be transferred east. This policy transferred “to the slender German defending forces precisely the advantages which Fighter Command had enjoyed during the battle of Britain.”¹⁵ This meant that British pilots shot down were invariably captured while German pilots could return to their airfields to fight another day. Even when it became apparent that this strategy was both costly in loss of pilots and aircraft and was not achieving its stated aim the program continued and was expanded to include arming some Hurricane fighters with small bombs to attack targets in occupied Europe.[†] The Hurricane, designed as a fighter-interceptor, was equipped with minimal armour, possessed a limited range and was flown by pilots unfamiliar with bombing. As a result the experiments were not overly successful but the idea did not die. This first step in converting fighters to bombers was a case of

[†] The losses in experienced leaders was severe as this sample demonstrates:
G. C. Douglas Bader, 22.5 victories, air to air collision over France, 8-9-41 POW
W. C. Robert Tuck, 29 victories, shot down over France by Flak, 1-28-42 POW
W. C. Brendan Finucane, 32 victories, shot down over French coast by Flak, 7-17-42
KIA

F.L Donald Morrison, 5.3 victories (highest scoring RCAF pilot at the time) shot down by ?? 11-8-42 POW

W.C. Leslie Ford, 6 victories, shot down by Flak over channel, 6-4-43 KIA

In addition to the loss of leaders was the high attrition rate in new pilots. One particularly tragic example occurred on June 2, 1942 when 403 RCAF lost seven pilots on one mission.

(Hess, W.N. The Allied Aces of World War II and Christopher Shores History of the Royal Canadian Air Force.)

searching for a new role in relation to strategic concerns and was not dictated by battlefield requirements. The birth of the fighter-bomber in the RAF was a compromise brought about by unforeseen circumstances with far reaching consequences.

It is helpful to digress from the narrative at this point to examine the development of the weapons systems and tactics these fighters turned fighter-bombers were employing in the early stages of the war. Fighter aircraft design was a constant trade off of arms and armour versus speed and maneuverability. The fighters at the beginning of the war were, for the most part, capable of great acrobatic feats at high rates of speed but were lightly armed. The Supermarine Spitfire was no exception. Sleek and graceful, the early mark Spitfires were armed with eight Browning .303 inch machine guns, four in each wing. Firing rifle calibre bullets however, the Spitfire's destructive power - while adequate against other fighter planes - was of limited value against ground targets. Against armoured fighting vehicles, the .303 was virtually useless. The other stalwart of Fighter Command at the time was the Hawker Hurricane which was similarly armed. The Hurricane was an older design and was constructed of metal, wood and fabric components unlike the virtually all metal Spitfire and the new Hawker Typhoon. The Hurricane, the backbone of the RAF in the Battle of Britain, was already considered obsolete.

The Hawker Aircraft Company's Typhoon fighter-interceptor, originally intended to challenge the supremacy of the Supermarine Spitfire, performed poorly at altitudes above 20,000 feet and was ultimately converted to a fighter bomber role. Its exceptional handling qualities below 20,000 feet combined with its rugged

construction, its ability to carry large external weapons loads and heavy wing armament, and the fact that no aircraft in production in Britain was designed for ground attack, meant that the Typhoon was consigned to this.[‡] As with the Hurricane before it, the conversion of the fighter to bomber was not a perfect marriage. Equipped with an inline, liquid cooled engine and with only minimal armour protection, the Typhoon, despite its rugged construction, was vulnerable to fire from below.[§] This fact was stated clearly by AOC in C Fighter Command at a May 1943 meeting just prior to the creation of 2 TAF. Leigh-Mallory argued that additional armour was required to protect both pilot and vital components for aircraft engaged in ground attack missions.¹⁶ He also stated that:

the best type of aircraft for low flying attack was the radial engine fighter, where damage to the engine still left reasonable prospects of getting home, as opposed to the liquid cooled engine, where damage to the cooling system was fatal. [Hopefully] - a fighter of this type [will] eventually become available.¹⁷

For the RAF, no such fighter was to materialize and the full import of these factors became startlingly clear during the Normandy campaign. Unlike the German Henschel

[‡] This is not to say that other aircraft weren't tried in the ground attack role. Perhaps the most notable of these was the twin engine Westland Whirlwind, entering service in June 1940. Originally designed as a long range escort fighter the Whirlwind proved inadequate and was converted to a fighter-bomber by attaching bomb racks to its wings. However, due to its poor engine performance and high landing speed the Whirlwind was deemed unsuitable again and production ceased in December 1941. Gunston. World War II British Aircraft, p60.

[§] The Typhoon carried armour plate in three areas "to protect the pilot, oil tank and fuel pipes in the fuselage." (The Hawker Typhoon in Aeroplane, Feb. 11, 1944) The coolant system was unarmoured and remained the Achilles heel of this aircraft. Additional armour plating was added later in the war giving more protection in the cockpit and radiator. As the Typhoon was still tasked as both fighter and bomber however, the weight of the armour added had to be minimal so as not to seriously degrade the aircraft's aerobatic characteristics.

129 or Russian Il-2 Stormovik, which were specifically designed for ground attack and as a result were both heavily armoured against ground fire, the Typhoon was and remained a high performance fighter.

As offensive sweeps over the continent continued, the Air Ministry released a report on the requirements for aircraft attacking armoured fighting vehicles. German tank development spurred by experience on the Russian front resulted in ever improving armoured fighting vehicles that far outstripped the best armour the Western allies had. The need, therefore, for other means of combatting German armour were voiced by the army and the RAF responded with its current surplus weapon, the fighter. It was therefore argued that “the ‘tank buster’ should be fast, light on the controls and maneuverable. It should be armed with 20mm or greater calibre guns and armoured against fire from the ground and debris thrown up by the fighter’s own shells.”¹⁸ The report also concluded that the sight line for the guns “should be depressed 2° to the line of flight at best attacking speed”¹⁹ The irony is, of course, that these and other lessons had already been learned by 1917 and incorporated into new aircraft design at the time. However, no aircraft in the RAF possessed the combination of attributes described and equally important, no pilot desired a modified gun sight or other changes, that would impair his ability in air to air combat. Fighter pilot reticence in embracing the ground attack role was understandable. The Air Ministry itself noted that “ground attack bears little relation to air fighting”.²⁰ The negative reaction of fighter pilots to this new role became a morale problem as it was noted that “the assignment of fighter units to a fighter-bomber role struck a heavy blow to the self-esteem of those pilots first assigned to such duties.”²¹

With the anti-armour role now added to the repertoire of the fighter a suitable weapon was required to make this feasible. As it was clear that the Browning .303 was insufficient armament for taking on armoured fighting vehicles (AFV's), trials were conducted on alternative weapons, focusing on bombs and rocket projectiles. The problems were myriad. Equipping a fighter aircraft with either bombs or rockets meant attaching racks or rails under the wings, designing a new, stronger wing to take the increased load, adding additional wiring in the aircraft to deploy the weapons and training ground crew and pilots on how to maintain and use them. Only then could the focus turn to accuracy, delivering the weapon on target. Trials and operational data combined with statistical estimates revealed a troubling theme, one that was to plague close air support throughout World War II; hitting a small target in a fast flying aircraft was close to impossible. The results of early trials summarized in the following table indicate the scope of the problem.

**Number of Bombs to Give an Even Chance of Hitting
a Standard Point Target of Area 150 sq. ft.²²**

Height of Release (ft.)	Opposition		
	None	Moderate	Intense
50	60	300	400
100	100	500	700
250	200	1,000	2,000
500	300	1,000	2,000
1,000	500	2,000	4,000
2,000	800	4,000	6,000
5,000	1,400	7,000	10,000
10,000	7,000	30,000	50,000

(Table 1.1)

The conclusion reached as the data accumulated was that the only way to hit small targets was to drop a large number of bombs. Even then chances of success were

slim. A report written after the Dieppe raid commented that estimates of bombing errors, such as those listed in the table above, were considered optimistic, in other words, operational data indicated aiming errors were greater even than training exercises suggested.²³

Why was the task of ground support so difficult to accomplish? The method of ground attack fighter pilots used in World War II can be broken down into three basic types. Strafing was performed by low level attack which meant flying toward the target at heights as low as 10 feet above the ground and firing for as long as possible before pulling up. Such strafing attacks improved accuracy and were effective against trucks and other soft skinned vehicles but were only suitable in flat, open country. For the firing of rockets and dropping of bombs a shallow dive attack was employed, commencing at a medium altitude upwards of a few thousand feet and finally pulling up at just a few hundred feet above the target. As in a low level attack the accuracy of a shallow dive attack was very good with the benefit of the pilot having an easier time in identifying his target. The third type was a steep diving attack which began from far greater heights and due to increase speed in the dive required a pull out further away from the target, in excess of 500 feet. The accuracy of these types of attack with fighter aircraft was very poor and while strafing, rocketing or bombing could be employed in this manner, none were effective except for a very few skilled pilots.²⁴ A fourth attack type did exist in the form of a vertical dive attack, but it was considered “entirely impracticable under operational conditions.”²⁵ What becomes immediately clear is that all forms of ground attack, required extremely low flying to have any chance of success. In addition to putting the pilot at risk of hitting the ground the

danger from light and medium flak at low levels was thus increased. In aircraft that provided only minimal armour protection against ground fire the engine and radiators were thus exposed to critical damage by even one piece of shrapnel. It was becoming clear that this new and sudden shift in the operational use of fighter aircraft was to suffer from the lack of a clearly defined concept of close air support doctrine and requisite development of aircraft to provide it.

Side View of Strafing Attack²⁶ (Fig. 1.1)

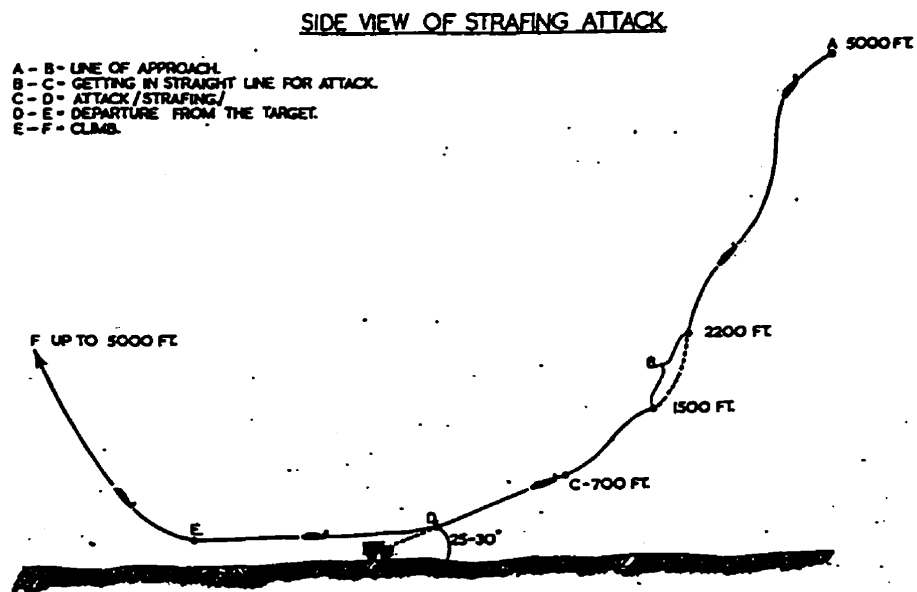

Side View of Rocket Projectile Attack²⁷ (Fig. 1.2)

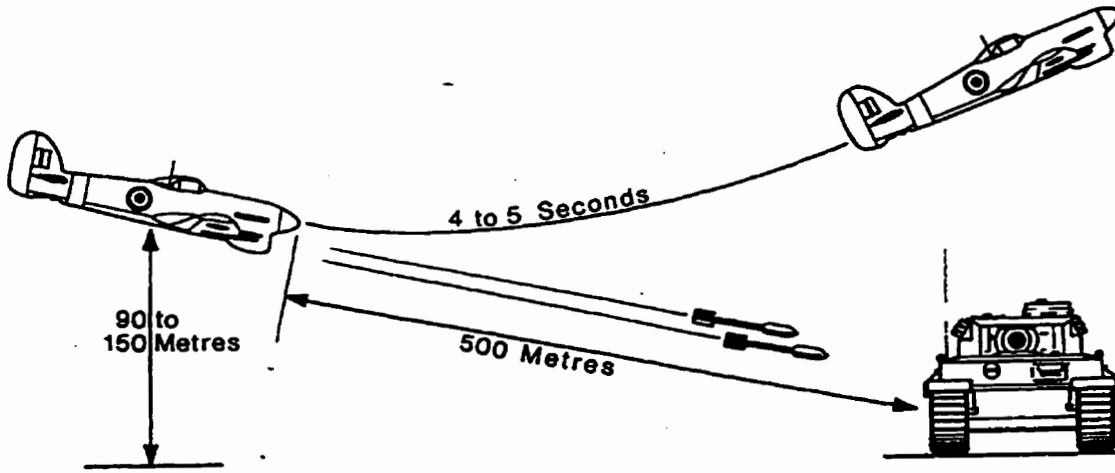

Side View of Dive Bombing Attack²⁸ (Fig. 1.3)

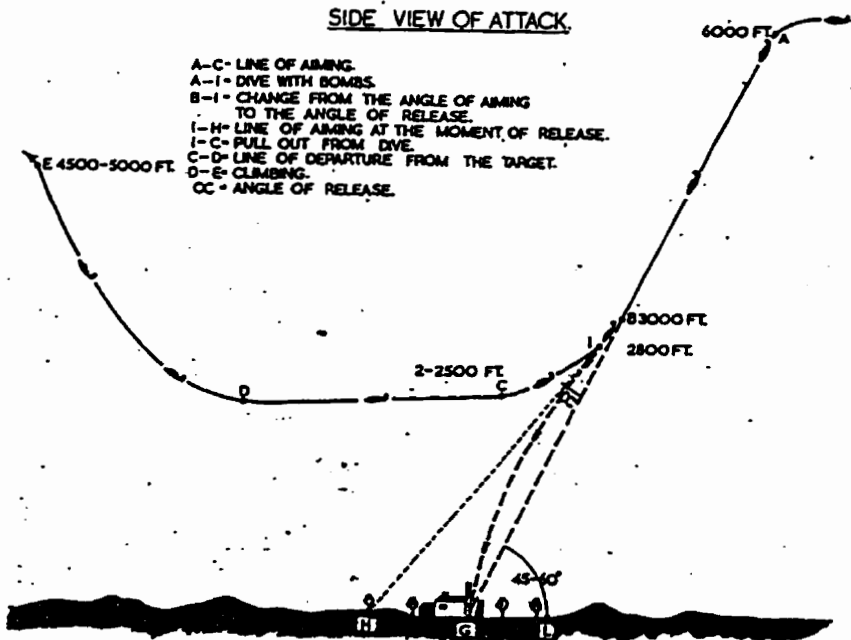

The arming of fighter aircraft with bombs was not a new idea in World War Two. In fact very little had changed since the first bomb racks had been fitted to bi-plane fighters in the First World War. Built and designed with speed and maneuverability in mind the British fighters of the day exhibited smooth, streamlined exteriors for minimal drag. Placing bomb racks and bombs under the wings detracted from the performance of the fighter, making it less competitive in air-to-air combat. The aging Hurricane was deemed suitable as it was already considered obsolete in direct air-to-air combat with the Luftwaffe's fighters and required fighter escort of its own. Fighter Command Tactical Memorandum No. 13 circulated in August 1941 stipulated the type of bomb and tactics to be employed against specific targets. The standard bomb used by the 'Hurribomber' was the 250lb General Purpose (GP) bomb. The method by which this bomb was to be dropped, however, was less than standard. In a low-level attack pilots were told to sight along the nose of their aircraft then release the bomb when the target was "a nose length ahead of the aircraft."²⁹ In diving attacks pilots were instead instructed to sight "along the top of the engine cowlings" and release the bomb(s) at the appropriate time.³⁰ Crucial in a pilot's calculations was the time set on the bombs fuse. Despite the report's endorsement of low level bombing attacks the attached appendix noted that bombs fuzed for instant explosion should be dropped from no lower than 1,000 feet.³¹ Only with a delayed fuze which the report gives as 11 seconds can lower level attacks be performed safely.³² The danger to aircraft and pilot from the bomb blast was significant, especially to small single engine fighters designed for a very different battlefield.

Rocket Installation³³ (Fig. 1.4)

**Typhoon IB
Mk I Rocket
Rails**

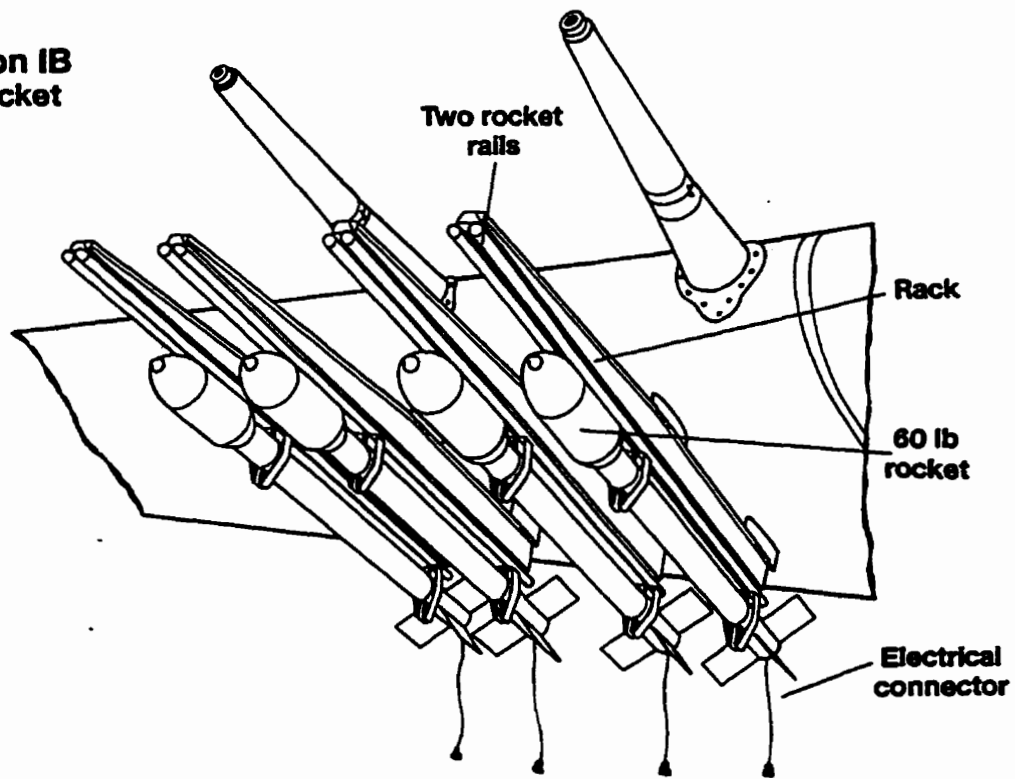

The alternative to bombs was the rocket projectile, consisting of an explosive warhead mounted on the end of a thin cylinder with fins, the interior of which was packed with a solid fuel that propelled the rocket forward as it burned. Trials of rocket projectiles began with the fitting of a 3 inch armour piercing warhead, weighing 25lbs, on Hurricane fighters. The low initial velocity of the rocket at 340 ft. per second and the quite substantial gravity drop meant that a standardized attack method was crucial if targets were to be hit.³⁴ Low level and shallow dive attacks were considered suitable for the rockets. The 3-inch rocket did not attain its maximum velocity of 1,850 ft per second until it had traveled over 2,000 feet. This meant that to optimize armour penetration the rockets had to be fired from at least 650 yards away from the target, but with longer ranges came increased aiming errors. Clearly, something had to be done. Trials were conducted using a 2-inch hollow charge rocket

which it was hoped would have the same hitting power as the 3 in but weigh only a third as much. This would allow the rocket to be fired at close range thereby increasing accuracy as the hollow charge did not rely on velocity to penetrate armour like the armour piercing shot.³⁵

Other trials used a faster burning propellant in the 3 inch rocket body to increase its initial release velocity thereby closing the range at which it could be fired. Since early estimates calculated that average aiming errors of 17.2 feet line (left or right of target) and 8.0 feet height (above or below target or in front or behind target) were to be expected, and considering that AP and Hollow Charge weapons require direct contact to have any effect, the early development of the rocket projectile did not look promising.³⁶

Further trials, conducted in 1943, offered more signs that modified fighter aircraft and fighter pilots were less than ideal for ground attack duties. Practice runs at Leysdown Air range suggested that rocket projectiles averaged a 45.5% chance of hitting a target versus 50% with the 40mm cannon. While an improvement over earlier trials, these statistics were based solely on training missions against stationary targets with no return fire. A new, heavier warhead was also tried with the rocket projectile. At 60lbs the explosive charge was devastating against locomotives but far less effective against concrete gun emplacements.³⁷ Other trials held at Shoeburyness on 25 February 1943, involved several weapons types against a stationary locomotive on track. The results of the trial were that the RP 60lb war head was considered the “ideal means of inflicting almost irreparable damage to a locomotive”.³⁸ It was also felt that the morale effect of the heavier rocket projectile made it a more potent

weapon as “it can be seen in flight and bears some resemblance to a flame thrower-cum-rocket, which makes a most startling noise, resulting in a very uncomfortable climax.”³⁹ Once again, however, the problem of accuracy was downplayed and other factors such as the morale effect came to the fore. A memo dated 1 August 1943 circulated by HQ Fighter Command noted that as the RP was not a “precision weapon”, it should be used only against large targets.⁴⁰

As trials with new weapons and tactics proceeded, the fight over whether the RAF should even engage in such activities continued apace. Despite the new policy of attacking ground targets there was little improvement in the development of a complimentary doctrine. Group Captain John Slessor, now commanding No. 5 Group, Bomber Command, reiterated the thesis of his earlier book in a paper that said, in part:

There has been too much tendency in all these battles for the Army to turn around and ask the Air Force to do what it should be doing itself. It is not the job of the Air Force to stop deployed tanks. That is the job of the anti-tank weapon on the ground, of the sapper with his tank traps and mines, of the properly trained infantryman...The job of the Air Force is to make it impossible for the tank to go on owing to a shortage of fuel, food and ammunition. In other words, I do not believe in close support at all except in the rare occasion when you have to throw in everything to avert a disaster (and that disaster should not threaten, if you have used your air properly from the beginning) or, of course to turn a retreat into a rout.⁴¹

With attitudes like these it should be no surprise that Army Cooperation was deemed a misuse of effort on the part of the RAF. Not expressed however was the simple fact that the RAF couldn't do the job even if it wanted to which it most certainly didn't. Chief of the Air Staff, Sir Charles Portal, was a firm believer in the concept of strategic bombing and an opponent of directing resources to other tasks. RAF production had

focused on heavy bombers and fighters with little to no time spent on attack aircraft. A 1942 paper by the Air Staff concluded that through the efforts of Bomber Command Germany and “her armies would have been reduced to a point where effective resistance to an allied re-entry on the Continent would no longer be possible - long before the end of 1944”.⁴² It further stated that with “the highest priority and sufficient energy - devoted to the development of a coordinated day and night bomber offensive - the war can certainly be won in 1944, and possibly in 1943.”⁴³ It is hardly surprising then that RAF support for the development of a ground attack doctrine and aircraft to conduct it was low on the priority list.

This attitude was reflected just as strongly within Fighter Command, the organization that now found itself in the business of ground attack. In 1943 Wing Commander E.M. Donaldson wrote a handbook on air combat for the United States Army Air Force (USAAF) and in it stressed the order of priority in which fighters should be used:

1. Home Defence.
2. The offensive sweep patrols over enemy country.
3. The maintenance of air superiority ...
4. Escort for bombers.
5. Ground strafing.⁴⁴

Priorities one through four were aimed at air to air combat clearly indicating what the RAF thought was the proper use of fighter aircraft. Considering that the Hurricane, Spitfire and Typhoon had been designed with those priorities in mind the RAF's reluctance to expand army co-operation is understandable.

Despite this attitude Fighter Command did what was previously unthinkable and in the January 1942 articulated a desire to work with the army in providing air support. Air Chief Marshal Sir Sholto Douglas, AOCinC Fighter Command, sent out a memo in January that said “it is essential that a much closer liaison should be established between the two services than generally exists at present” and instructed that training in Army support duties should be undertaken, when possible, by all fighter squadrons.⁴⁵ Needless to say the army concurred and a directive released by the Chiefs of Staff in the spring of 1942 strongly urged that “Army and R.A.F. formations work closely together in battle with the fullest knowledge of each others possibilities, limitations and procedure.”⁴⁶ However, in acknowledging that RAF units were involved in active operations, the directive conceded restrictions on aircraft participation in joint exercises, instead stressing that “full use will therefore be made of exercises without troops and aircraft, to study the technique of Army Air Support”.⁴⁷ Such an accommodation allowed Douglas’ successor, Leigh-Mallory, to pursue closer cooperation with the army on Fighter Command’s own terms. This growing interest in supplying fighter squadrons to train with the Army did not result in any significant increase in the resources allotted to Army Cooperation Command. Instead Fighter Command as a whole was to pursue this new strategy and thereby remain intact and independent. This new development did not go unnoticed and the AOC-in-C of ACC, Air Marshal Sir Arthur Barratt, complained that things were becoming “a little complicated” with Fighter Command now pursuing a role in ground support as well.⁴⁸ Several months later the Army Liaison Officer with Fighter Command echoed this sentiment, commenting that both Fighter Command and Army Co-operation

Command were “carrying out research almost independently with resultant waste of effort and confusion.”⁴⁹ This could not continue for long.

Along with weapon trials, experiments were carried out to determine the best form of what is now known as C3 - command, control and communication - for aircraft flying support missions. In May 1942 trials were held to improve the response time of fighters to calls from AASC and study the best way to provide the support. As well, Army Cooperation Tac R aircraft using VHF and HF radios were compared.⁵⁰ It was found “that Mustang aircraft especially equipped with VHF gave reports more clearly and at greater distances than the Tomahawk aircraft equipped with the type No. 19 HF set.”⁵¹ In this way it was envisioned that the Mustang could, after over-flying its target area immediately gain altitude and broadcast its report thereby speeding up the collection of intelligence. Another trial with VHF was the placing of a pack set in a vehicle with a tentacle so that pilots could be briefed on their way to the target. The trials showed that pilots could not find the tentacles and the pack set was not suitable for the job as it lacked power and range due to its small size.⁵² Despite the problems progress was being made towards some form of cooperation between the two services.

For its part the Army continued to press for aircraft to support land operations. The Imperial General Staff circulated a paper in June 1942 calling for no less than 109 squadrons to support ground forces, noting that “Army Co-operation has been the

⁵⁰ By this time Army Cooperation Command included both P-40 Tomahawk and Mustang I fighter aircraft. Neither aircraft was considered top line, the P-40 being basically obsolete in NW Europe before it arrived and the Mustang, in its original

Cinderella branch of the RAF, and the Army's effort's to get proper air support in reconnaissance, bombing and fighter cover has never had a fair deal."⁵³ In the fall of 1942 a detailed report was written by the Scientific Adviser to the Army Council at the request of the Director of Air, War Office, regarding Army requirements for air support on the battlefield. The Army view was that to date, including the First World War, "the RAF, in spite of many attempts, have never achieved decisive results by attacking rear areas of the enemy's armies" and noted that the reasons for this were:

- (a) Such attacks cannot prevent movement by night.
- (b) Much protection against an attack is now achieved by proper dispersion.
- (c) Vital installations will always be strongly protected by A.A. fire.
- (d) The further behind the enemy's front we ask our bombers to go, the greater will be the chances of their interception by enemy fighters.⁵⁴

Instead, the Army argued that air support must be concentrated "at the decisive point to achieve success", that being the front lines.⁵⁵ The RAF view begged to differ.

Their stance was that leading up to a battle the role of air support was in "bombing of enemy supply lines and bases" and that only for the few days before a battle and the immediate battle itself would air support be "chained to the battle area", a less than positive assessment.⁵⁶ Once the battle had moved to a break-out phase air support would once again revert to attacks far away from the front lines. The RAF also insisted that "the long range heavy bomber force is not suitable for use by day in close support roles".⁵⁷ The RAF report argued that the apparent disagreement between the two parties was not as great as it appeared. All were in agreement that if methods could be devised to allow air support to operate closely with forward troops, close air

configuration with an Allison engine, was relegated to Army Coop Command due to

support could become a decisive factor. The problem of identifying and hitting small targets from the air was, however, considered difficult if not insoluble.⁵⁸

The creation of the Second Tactical Air Force appears at first glance to represent a massive shift in RAF policy. Previously, the RAF had distanced itself from the ground war, willing only to tolerate the existence of the rather ineffectual Army Cooperation Command. But by the summer of 1943 the Germans had suffered their worst defeat of the war to date at Stalingrad, the Desert war had been won, and the Western Allies could begin to seriously consider a return to the continent. Within that context 2 TAF seemed a genuine step towards greater Air/Army cooperation. However, appearances were deceiving. At the Chiefs of Staff meeting held on 11 May, 1943, it was confirmed that, with the creation of the Second Tactical Air Force, the Army Cooperation Command would cease to exist on 1 June, 1943. It was also noted that the large majority of the headquarters staff for 2 TAF would come from ACC.⁵⁹ On the surface the elimination of the Army Cooperation Command made little sense as it had been in existence since 1940 and was specifically tasked with what the RAF were now finally embracing in a much grander way. Five days later a rather spurious logic was offered:

Army Co-operation Command was formed in December 1940 to organize, experiment and train in all forms of land/air co-operation - the main purpose for which Army Co-operation Command was created has now been fulfilled. It is now necessary to pass from the phase of development to the phase of action and to adapt the organization of the Metropolitan Air Force to suit.⁶⁰

its barely adequate performance.

Coming as it did in May of 1943 with no real prospect of supporting land forces across the channel until the summer of 1944, a year away, it was a stretch to term 2 TAF 'the phase of action'. For that matter, to state that the purpose of ACC had been fulfilled, with the implication that Army Air cooperation was now an ingrained, well understood and well executed function understood by both the army and air force was, to put it mildly, an exaggeration. It is evident that the RAF were unwilling to see Fighter Command gutted with the bulk of its squadrons transferred to the ACC and instead gave the command that had saved Britain a new role that would guarantee its future.

To be fair to the RAF though, one must consider the state of events by the summer of 1943. The RAF had, to an extent the other services had not, taken the offensive to the heart of Germany almost single-handily, and suffered appalling losses in doing so. While the Army was engaged in North Africa it was understood by all concerned that the Western desert was a side show. The American heavy bombing campaign that was to garner so much publicity later was in its infancy at this point, which meant the only substantial offensive weapon the western Allies could use to assist their ally to the east was the RAF. It is therefore not surprising that the RAF fought and succeeded in setting the terms for a tactical air force that acknowledged their contribution to the war effort. At the same time it was realized that both the men and machines for this new organization would have to come from "existing static Commands and to a very large extent from Fighter Command."⁶¹ The conclusion reached was that "it appears difficult to deny the Air Force the right to select what they consider to be the most suitable static organization on which to build the supporting RAF organization."⁶² For its part the Army was not about to complain because after a long and difficult struggle

it was finally getting a large air force dedicated to serving its immediate needs on the battlefield, although to what extent remained to be seen.

Army Air Training Instruction Pamphlet⁶³ (Fig. 1.5)

26/CS Publications/1943
ARMY AIR TRAINING INSTRUCTION

No. 1 1943
Army Air Operations

(PROVISIONAL)
This instruction supersedes
Army Training Instruction No. 6, 1941

Prepared under the direction of
The Chief of the Imperial General Staff
and The Chief of the Air Staff
THE WAR OFFICE JULY
THE AIR MINISTRY 1943



RESTRICTED

The information given in this document is not to be communicated, either directly or indirectly, to the Press or to any person not authorized to receive it.

This document must NOT fall into enemy hands!

CROWN COPYRIGHT RESERVED

With the creation of this new air force from Fighter Command a new doctrine was required. The result was Army Air Training Instruction No.1 published in July 1943. Prepared under the joint direction of both the army and the air force the initial doctrine nonetheless perpetuated the already entrenched opinions of the two services on the way air support could best assist ground forces. The cover for the Army Air Training Instruction pamphlet was illustrated with a sketch that seemingly portrayed the ideal situation of close air support. Just yards away from a British soldier, bomb-laden Hurricane fighters sweep down and, as evidenced by the smoke and explosion, destroy the ground target in front of him. The sky in the immediate vicinity is clear and no flak or enemy fighter defences are evident. Also conspicuous by their absence are the heavy and medium bombers of Bomber Command. Inside the pamphlet the writers attempted to make that ideal a reality.

First, centralized control by the RAF was confirmed as being the right method. The rationale for centralized control was the ability to bring the full weight of the air support to bear on one 'decisive point':

Flexibility is the primary characteristic of any air force and its commander will be unable to exploit this, to the full, unless he has centralized control of the available air forces. Dispersion of air resources and sub-allotment to subordinate formations are generally detrimental to successful results.⁶⁴

Air resources, the RAF argued, must not be treated as a mere support arm of the Army in the way that artillery was. The new doctrine also stressed that after the primary mission of gaining air superiority had been attained, tactical air forces would focus on 'Indirect Support', ranging far behind enemy lines attacking all manner of targets that would eventually, though not immediately effect the land battle. Therein

lies the paradox. The Army was willing to accept centralized control if it meant air power could be delivered to the battlefield where it was needed most, directly in front of advancing troops, exactly as depicted on the cover of the document. The RAF however, argued that direct/close support was difficult and not the best use of air power. Under the heading 'Suitability of Targets' the RAF made it clear where their support would be placed:

Generally speaking, the more concentrated the target, the easier it is to attack it effectively. Since the enemy dispersion will be greater nearer the front line, the majority of targets will be found in the rear of the battle area.⁶⁵

In addition, targets close to the front line were invariably within artillery range and the Instruction pamphlet stated that it was "important that aircraft are not used when other support, such as artillery, is sufficient for the purpose."⁶⁶ It was also noted that to assign fighters to direct support meant drawing them away "from their main role" of gaining and maintaining air superiority.⁶⁷ Factoring in the small but important clause that complete air superiority was "impossible" it appears clear that the new doctrine provided the RAF with a virtual carte blanche to conduct operations as it saw fit while the Army was left with a hollow document that gave little if any concrete assurances of direct support to its forces.⁶⁸ This should not be interpreted as a sweeping condemnation of the RAF. By ensuring they maintained control, the RAF believed they could best assist in waging and winning the war. One might consider it a form of what is euphemistically called 'tough love'; the RAF would support the army but not necessarily in the manner the army thought it needed. In the case of applying air power against the enemy, the RAF believed it knew what was best and with the

somewhat naïve agreement of the army, were successful in creating a doctrine that reflected this.

The pamphlet also claimed that the tactical air forces could provide a positive morale effect by shooting down enemy aircraft within sight of allied troops.⁶⁹ While it is true that in the First World War air battles above the trenches were avidly watched by the soldiers below, it should be remembered that the aircraft flew at speeds of as little as 40 - 50 miles per hour at virtually tree top level making identification of the colourfully painted aircraft easy. That aerial combats of World War Two conducted by fighters in aircraft capable of speeds of 400 miles per hour with service ceilings in excess of 30,000 feet would offer any morale effect to the troops below seems uncertain at best. The RAF knew this; Wing Commander Donaldson's handbook for the USAAF stated clearly that "Nowadays very few combats are ever fought at altitudes of less than 17,000 feet - so it is essential - that as much practice as possible should take place at operational altitudes - that is above 17,000 feet."⁷⁰ What did have a positive morale effect on forward troops, as we shall see, was witnessing friendly aircraft attacking enemy positions immediately in front of them, just as the cover illustrated.

Historians concerned with writing a logical narrative would (and have) linked the creation of the Second Tactical Air Force in the summer of 1943 with the fruition of years of trial and error in developing a sound, workable air support doctrine. It is useful to remember however, that events do not necessarily comply with good literary style. The reality was that a large portion of Fighter Command had a new name, an untested doctrine and no army in the field to support. RAF acquiescence to a doctrine

that purported to support the land forces seemed to meet the needs of the army. However, in accepting this new role the RAF maintained that it alone knew how best to apply air support, something the army was willing to concede. Without an army engaged in land operations in North West Europe to test this new tacit understanding, however, the RAF preference for indirect support over close support was adopted by default. Trials of new weapons and tactics support this stance as accuracy remained the central challenge facing the provision of air support to the battlefield. Without it, air support remained a weapon best employed away from, not near, the battlefield. Within this context the Second Tactical Air Force began operations with the knowledge that in less than one year's time this new doctrine would be put to the test in North West Europe.

End Notes to Chapter One

¹ Douglas Robinson. 'Strategic Bombing' in Warplanes & Air Battles of World War I, edited by Bernard Fitzsimons. pp 132 - 136.

² L.K. Blackmore. Hawker: A Biography of Harry Hawker, p 127.

³ Blackmore. Ibid.

⁴ Blackmore. Ibid.

⁵ Malcolm Smith. British Air Strategy Between the Wars, p 310.

⁶ R.L. Rimel. R.A.F. between the Wars, p 27.

⁷ Minutes of Air Ministry Planning Committee February 28, 1935. p 1. AIR 9/6 131884

⁸ Ibid. p 5.

⁹ Ibid. p 6.

¹⁰ Ibid. p 1.

¹¹ W.A. Jacobs. "Air Support for the British Army, 1939 - 1943". Military Affairs. December 1982, p 175.

¹² Draft Development of Air Support to the Army 1939 - 1945, 25 May 1945, p 1. WO 233/60 xc154610

¹³ Bill Gunston. World War II British Aircraft. p 60.

¹⁴ C.E. Carrington "Air Liaison Officer" - Unpublished Manuscript, Chapter III, p 3.

¹⁵ John Terraine. The Right of the Line: The Royal Air Force in the European War, 1939 - 1945. p 284.

¹⁶ Minutes of Meeting Held by Commander in Chief Home Forces at GHQ on Tuesday, 11 May, 1943 to discuss Army Air Support. WO205/567 154331

¹⁷ Ibid. WO205/567 154331

¹⁸ Air Ministry Air Tactics "Fighter Attack of Armoured Fighting Vehicles" May 1942, p 3. AIR 23/1861 9918

¹⁹ Ibid. Air 23/1861 9918

²⁰ Ibid. Air23/1861 9918

²¹ Brereton Greenhous et. al. The Crucible of War 1939 - 1945: Official History of RCAF, Volume III, p 228.

²² Report on the Army Requirement for Direct Support in Battle 30 Nov 1942, Appendix A, p 19. Air37/760 139570

²³ Ibid. Air37/760 139570 Appendix B, p 26.

²⁴ Ibid. Air37/760 139570 Appendix B, p 27.

²⁵ Ibid. Air37/760 139570

²⁶ Air Ministry. Tactics Used by Spitfire Day Fighter/Bomber Squadrons of the 2nd Tactical Air Force During the Campaign in Western Europe. Tactical Paper No. 4, 1947, Appendix F. AIR 20/6857 92550

²⁷ Christopher Shores. Ground Attack Aircraft of World War II. p 157.

²⁸ AIR 20/6857 92550 Appendix B

²⁹ The use of the Hurricane Bomber from HQ Fighter Command, Tactical Memorandum No. 13, 29 August, 1941, p 2. PRO 16/334 xc3848

³⁰ Ibid. PRO 16/334 xc3848

³¹ Ibid. PRO 16/334 xc3848

³² Ibid. PRO 16/334 xc3848

³³ Jerry Scutts. Typhoon/Tempest in Action, p 19.

³⁴ Report on The Army Requirement of the Royal Air Force For Direct Support in Battle, Appendix B. The War Office, Scientific Adviser's Department, 30 November, 1942, p 32. AIR 14/3946

³⁵ Ibid. AIR 14/3946 p 33.

³⁶ Ibid. AIR 14/3946

³⁷ Efficacy of R.P. and 40mm Weapons Report 3 August 1943 Fighter Command HQ p 2. AIR 16/705 00074

³⁸ Appendix C Fighter Attack on Locomotives - D. Arm D. Trial Interim Report, p 6.
Air 16/705 00074

³⁹ Ibid. AIR 16/705 00074

⁴⁰ Ibid. AIR 16/705 00074

⁴¹ W.A. Jacobs. p 175.

⁴² Relative Bombing Efficiency - Actual Results to be Expected Through Improved Strategy, Tactics and Equipment, Air Staff, 14 October 1942, p 7. AIR 20/3360 xc184616

⁴³ Ibid. Air20/3360 xc184616

⁴⁴ Wing Commander E.M. Donaldson. 'Notes on Air Gunnery and Air Fighting 1943' in Fighting in the Air: The Official Combat Technique Instructions for British Fighter Pilots, 1916 - 1945, p 214.

⁴⁵ AOC in C Fighter Command to Groups, 24 January, 1942. AIR 16/776

⁴⁶ GHQ Directive on Training in Co-operation with the RAF 30 April, 1942. AIR 16/552 xc153917

⁴⁷ Ibid. AIR 16/552 xc153917

⁴⁸ Barratt to Carr, HQ, Eastern Command, 13 March, 1942. AIR 39/129

⁴⁹ A Summary of Recent Exercises within Fighter Command, August 1942. AIR 16/776

⁵⁰ Report on Army Air Support Trials at RAF Station Digby with no. 7 A.A.S.C., Fighter Command, 18 May, 1942. AIR 16/552 xc153917

⁵¹ Ibid. AIR 16/552 xc153917

⁵² AIR 16/552 xc153917 See also IMW Papers Lt. Col M.A. Philip unpublished manuscript 'Worm's Eye View', p 8.

⁵³ Brian Bond, ed. Chief of Staff, London, 1974, II, pp. 19 - 20.

⁵⁴ Report on The Army Requirement of the Royal Air Force For Direct Support in Battle. The War Office, Scientific Adviser's Department, 30 November, 1942, p 6. AIR 14/3946

⁵⁵ Ibid.

⁵⁶ Ibid. p 7.

⁵⁷ Ibid.

⁵⁸ Ibid.

⁵⁹ Ibid.

⁶⁰ Letter from Chief of Staff GHQ Home Forces 16 May, 1943

⁶¹ Organisation of Air Support for the Army in Continental Operations - Phase 2
WO205/567 154331

⁶² Ibid. WO205/567 154331

⁶³ Army Air Training Instruction No. 1 1943 Chief of the Imperial General Staff and
Chief of the Air Staff July 1943. AIR 8/988 92396

⁶⁴ Ibid. p 4.

⁶⁵ Ibid. p 8.

⁶⁶ Ibid. p 5.

⁶⁷ Ibid. p 7.

⁶⁸ Ibid. p 4.

⁶⁹ Ibid. p 5.

⁷⁰ Donaldson. p 223.

Chapter Two

By 1943 the Allied military commanders agreed that in order for a return to the continent to succeed four pre-conditions must exist. They were air superiority, control of the English Channel, evidence that Allied deception had convinced the Germans that the Pas de Calais, not Normandy, was the real target, and ability to isolate the battlefield, or at least delay reinforcements through air power. Of these, two clearly fell within the purview of air power. The first, air superiority, appeared to have been achieved far quicker than had been imagined but the level of resources required to maintain it was still vast. Nonetheless, with a decreased Luftwaffe presence within range of the aircraft of Fighter Command, other roles could be allocated to the squadrons in an attempt to isolate the battlefield and support the ground forces. In the summer of 1943, these requirements resulted in the creation of the Second Tactical Air Force.

Unfortunately, the development of aircraft, weaponry and doctrine for ground support operations underwent little further advancement in the year after the formation of the Second Tactical Air Force in June, 1943. Indeed, 2 TAF continued to train and deploy squadrons for missions over France and the low countries which emphasized air-to-air combat and attacks upon readily identifiable ground targets. Although it was known that in less than one year's time 2 TAF would be involved in supporting land operations on the continent, the dichotomy of views between the army and the air force regarding how this support could best be provided meant the Normandy campaign would begin with much still left to learn.

Although the overall air plan for the return to the continent was not officially articulated until 15 April 1944, the first of its four phases had already been achieved by the time of its publication. In essence, phase one was “to win air superiority, to disrupt enemy communications, to provide air reconnaissance of the Assault area, and to attack enemy Naval Forces”¹ As we shall see, the two most critical parts of phase one, the need to “attain and maintain an air situation whereby the G.A.F. is rendered incapable of effective interference with Allied operations” and to “provide continuous reconnaissance of the enemy’s dispositions and movements”, were for the most part extremely successful.² However, with this success came a dilemma for 2 TAF. The lack of a serious Luftwaffe threat meant that most of 2 TAF squadrons, equipped with high performance fighters designed for air-to-air combat such as the Spitfire and Typhoon, were in search of other missions. As Chapter One demonstrated, this dilemma was not new, yet it was to continue to prove difficult to address.

When the production of dedicated ground attack aircraft was rejected by the RAF in the interwar period, aircraft production naturally focused on two main types, the single engine fighter and multi-engine bombers. Policy dictated that existing aircraft types be ‘multi-purpose’ and so the fighter became the fighter-bomber. However, it was evident that the “chief weakness in the fighter-bomber [lay] in the direction of design [-] originating from the earlier conceptions of the defensive interceptor.”³ The result was that, by the summer of 1943, when it was clear that a more specific aircraft design that included such attributes as increased armour and an air to ground sighting mechanism would have been advantageous in the direct/close support role, it was too

late. In fact, the successor to the Typhoon, the Tempest, was already in production; it too was designed as a high altitude interceptor.⁴

The decisions of the interwar period had now come home to roost, resulting in the main component of 2 TAF being the single engine fighter. Air superiority virtually guaranteed that allied ground forces could deploy with little disruption from the Luftwaffe. It also meant that the German command structure would be unable to benefit from aerial reconnaissance of allied forces and that air support provided to the ground forces could proceed free from any serious air-to-air threat. On the other hand, as the majority of the aircraft employed were fighters, their suitability in the ground attack role was limited due to their high speed, vulnerability to ground fire, and poor accuracy; moreover, they were flown by pilots trained and indoctrinated in air-to-air combat.

Recent studies on tactical air power, perhaps in an attempt to distance themselves from early works, have all but ignored the contribution of air superiority. Nonetheless, such studies have still praised the work of the tactical air forces by focusing on the 'morale effect'. Impossible to quantify except in quite specific case studies, the contribution of tactical air power has now shifted from 'destroyer' to that of 'terrorizer'. A truer representation would be that of 'protector'. Just as Germany considered an invasion of England impossible without air superiority so too did the Allies in their planning for a return to the continent. Once ashore in France the landed forces would rely almost exclusively on sea transported supplies and reinforcements, which would remain highly vulnerable to disruption by air attack without

overwhelming air power for protection. Allied troops on the ground would benefit too from such protection, allowing the movement of troops and supplies once ashore to proceed relatively unhindered. When compared to the disruption and 'morale effect' historians now attribute to tactical air power on German ground operations it seems clear that any other situation would have had serious consequences on Allied land operations. That this did not occur is perhaps the single most important accolade that can be given to tactical air power.

The unpublished history of 2 TAF noted that the RAF "regarded the re-entry into Europe as an operation requiring an intensification of effort rather than the opening of a new campaign."⁵ As such, RAF determination to maintain control of 2 TAF seems quite sensible. However, it also ensured that army-air cooperation would for the year leading up to the invasion of France, remain weak. The RAF strongly believed that its single most important contribution to supporting ground forces was air superiority. The tool for that mission was the fighter. In the summer of 1943, with less than a year before the invasion, little time was left to create a wholly new air force designed for tactical use in conjunction with land operations. This should not be surprising. The Luftwaffe, with its focus on Blitzkrieg and dive bombers, epitomized by the Stuka, had been a tactical air force unable to make the switch to strategic one. It is not surprising then that 2 TAF operations continued virtually identical to those conducted by Fighter Command before it, namely, offensive fighter sweeps and ground attacks against targets of opportunity. At the same time, squadrons formerly with Army

Cooperation Command, now equipped with the Mustang I, continued reconnaissance flights over the continent.

Despite the seeming continuity of operations significant changes were taking place with the formation of 2 TAF. Perhaps the most important was the move towards mobility. Ground crew formally attached to a specific squadron now found themselves joined to a specific Airfield, ready to service any squadron that might land there.⁶ This greatly enhanced the ability to place squadrons where ever they might be needed on short notice without having to move the quite considerable ground support with it. As well, more Airfields were set up in southern England with troops living under canvas, a precursor to conditions soon to be found in Normandy, reflecting the need to keep airfields as close to the battlefield as possible.

Command of the new composite air force was given to Air Marshal Arthur Coningham, former commander of the Western Desert Air Force. On the surface Coningham seemed the perfect choice. Both he and Air Marshal Tedder had worked well with General Bernard Law Montgomery in the desert creating a tactical air force that cooperated well with the Army. However, England was not the desert. Montgomery was now not only the commander of 21 Army Group, but also the land forces commander for the invasion. Due to its distance from the command nexus in England and the view of many, certainly including the RAF, that it was secondary in importance to the overall war effort against Germany, the North African campaign was not typical.

Coningham's strong views on the importance of providing air support to the army were at odds with RAF policy. While they could be tolerated in the desert with the relatively few squadrons involved, the situation in England was far different. So too was the relationship between Coningham and Montgomery. By November 1943 the air forces command structure for the invasion was settled with the creation of the Allied Expeditionary Air Force, commanded by Air Chief Marshal Sir Trafford Leigh Mallory. That same month Fighter Command officially ceased operations and the squadrons that had not been transferred to 2 TAF were renamed Air Defence of Great Britain. In 2 TAF, 83 Composite Group was to be lead by Air Vice Marshal Harry Broadhurst, who had taken over command of the WDAF after Coningham. 83 Group was originally tasked with supporting 1st Canadian Army but instead became attached to British 2nd Army. 84 Composite Group was commanded by Air Vice Marshal L.O. Brown and would support 1st Canadian Army in France. 2 Group, composed of light and medium bombers, was to be commanded by Air Vice Marshal B. Embry and was not attached to a specific army.⁷

In a move to simplify the command structure Coningham was also named commander Advanced AEF, which theoretically put him at par with Montgomery as commander of the allied ground forces and 21 Army Group. However, personality conflicts between the two, in part due to Coningham's anger over Montgomery taking the credit for the desert victory while ignoring the contribution of the air force, and in part to Montgomery's refusal to view Coningham as an equal, hindered closer ties between the two forces.⁸ While it is true that such animosities in no way affected the

ability of a pilot to hit a ground target, the lack of closer cooperation ensured that on D-Day there was still much to be done for the land and air forces to cooperate to their full potential.⁹

One of the hurtful aspects of this lack of good will as far as the army was concerned was reflected in the training of pilots prior to the invasion. Pilot training for fighter aircraft slated to perform ground attack missions continued to be first and foremost in air-to-air combat techniques. The training syllabus for the Typhoon pilot made it clear that “a ground attack pilot’s aim is - to shoot down and destroy enemy aircraft”.¹⁰ This is not surprising as the RAF had consistently maintained that its biggest contribution to land operations would be in the ‘gaining and maintaining’ of air superiority. However, in practical terms this meant that the designated ground attack component of 83 Group, the Typhoon, was being flown by pilots receiving as little as 18 hours in ground attack instruction. A scant 2 hours was allocated to ‘pin-pointing’, the ability to locate a target on the ground, with expected results. Major trials conducted in 1943, including attacks on up to a full division of simulated German artillery, were abysmal failures. Even with the precise six-figure coordinates, pilots had great difficulty in finding the guns, never mind attacking them accurately.¹¹

Another ramification of the lack of cooperation between the main personalities was limited combined training of air and ground forces in working together on the battlefield. The RAF were involved in active operations so the amount of time and number of squadrons available for such training were by necessity limited.¹² When training sorties were authorized, they most often involved small numbers of aircraft

engaged in 'Low Level Attacks' against the allied forces they would later be in support of, hardly the type of cooperation the army desired.¹³ A better working relationship between the two main commanders would no doubt have improved what training there was, but again it is important not to overemphasize the importance of personality conflict.

Exercise/Operation STARKEY, conducted in October 1943, is a perfect example of the difficult relationship between the army and the air force. The reason for the split designation was that while the air force would in fact conduct real operations over France, consisting of offensive fighter sweeps, the army could only simulate an amphibious assault on the French coast. The result was less than spectacular. 21 Army Group complained that the current system would not be "satisfactory in the event of invasion operations."¹⁴ It was also observed that single engine fighter aircraft were less vulnerable to ground fire at medium altitudes than when flying at ground level. By January 1944 results from the Anzio assault were to emphasize this already obvious dilemma; "unless aircraft fly low and press home their attacks to close range returns are small."¹⁵ Training and operational data were painting a grim picture indeed for the prospects of direct/close air support.

After STARKEY a series of suggestions was made to improve direct/close air support. Among them was that the physical separation of the Air and Ground commands had to be overcome if they were to work effectively. In arguing for a centralized system to better exert control, the report accedes that it could work only "if communications and the machinery are extremely efficient, and the necessary

standards can only be reached by constant practice.”¹⁶ The relationship however, between the army and the air force, soon to become polarized between Montgomery and Coningham, ensured that such measures were difficult to implement.

While the working relationship between the army and the air force remained cool, weapons development proceeded at a rapid pace. The rocket projectile made its operational debut in June 1943 and with it a series of attacks against the rail network in France were undertaken. A study conducted just before 2 TAF became operational attempted to determine the accuracy of both bombs and Rocket Projectiles as used by fighter aircraft against small targets, especially bridges. The results were disappointing. For 777 bombs dropped only 6 to 8 hit their target or approximately 1% while of 1,844 rockets fired between 40 and 82 hit their target for a success rate of 2% to 4%.¹⁷ While the R.P. appeared slightly more accurate, the destructive power of a single warhead was far less than that of a single bomb. Later studies of R.P. attacks against targets in the Pas de Calais area found that pilots were using less than optimum tactics when firing their rockets.¹⁸ Yet another study made on attacks carried out in April 1944 noted why difficulties in accuracy persisted:

In order to hit a small target with RP, the pilot must be at the right height and dive angle, have the correct speed, have his sight on the target and the right angular depression on his sight, make the correct wind allowances and be free from skid or ‘g’; but in addition he must pull out the right amount for the right time.¹⁹

The effect of flak on accuracy was clearly pegged as the biggest contributing factor, with the intensity correlating directly with increased inaccuracy. Facing no flak pilots were releasing their weapons below 5,000 feet but with intense flak this distance

sky-rocketed in some cases to over 11,000 feet.²⁰ Clearly pilots were wary of flak, and with good reason. A report written by the Operational Research Section attached to Fighter Command/2 TAF stated that of the 1,072 sorties flown between January and July 1943 90 aircraft were lost.²¹ 89% of the casualties were due to flak, with only around 5% being caused by enemy fighters.²² In return, four enemy aircraft were destroyed, over 338 locomotives damaged to varying degrees, and there were numerous successful attacks on Motor Transport and barges.²³

The three main single engine fighter aircraft of 83 Group, the Mustang, Spitfire and Typhoon, all used liquid cooled engines with radiators positioned on the underside of the airframe. A puncture in the cooling system was therefore more serious, and made more likely because of its location - with often terminal results. The problem was so severe in the Typhoon that a small gauge was installed in the cockpit to warn the pilot that his engine was about to seize.²⁴ Prior to its installation pilots had no indication they were losing coolant until the engine stopped, an almost fatal occurrence if they were in a dive or at low altitude. By comparison, the United States Army Air Force's P-47 Thunderbolt "with its big air cooled [radial] engine and heavy protective armour, has shown itself outstanding in its capacity to swop punches at close range, get away with it and come back for more."²⁵

The British built fighters of 83 Group, along with inappropriate engines and insufficient armour, also suffered from a lack of range. This was inevitable in that "the chief weakness in the fighter-bomber lies in the direction of design originating from the earlier conceptions of the defensive interceptor type".²⁶ Added to this was the lack of

a suitable bomb/rocket sight for aiming. It is no wonder that the British post war report on air support in North West Europe “suggested that the army is directly interested in future air force production policy as it affects the fighter-bomber.”²⁷ However, it was too late to begin production of a more suitable ground attack fighter even if the RAF had wanted one, and there is no evidence that they did. Extensive trials were undertaken to develop the best possible tactics to ensure accurate delivery of bomb and rockets, but the conclusion reached was that “conditions of those trials are, however, very different from operational conditions, so that results are of somewhat limited value in deciding the best operational tactics.”²⁸ Pilot inaccuracy caused by evasive action or the releasing of weapons too far from the target remained a common occurrence throughout the Second World War.

The attacks against occupied France and the Low Countries continued. Despite the limitations of both aircraft and tactics successes were achieved. Perhaps the greatest offensive contribution 83 Group made in the period prior to D-Day was the disruption of enemy communications in and around the invasion area of Normandy. This was best achieved by the interdiction of rail traffic. A report released by HQ 2 TAF on September 12, 1943 noted the increased defensive measures being taken by the Germans to guard rail traffic, and characterized it as illustrating “grave concern” on the part of the German High Command.²⁹ Locomotives were being modified with steel plate and concrete as well as the addition of anti-aircraft wagons to trains all in an attempt to withstand the constant air assault.³⁰ These developments were properly understood to reflect the growing strain being placed on the rail network servicing the

German Army, and the added drain of having to take extraordinary measures to deal with it. The fighters and fighter-bombers of 83 Group were taking their toll, but in a role far different from the close/direct support envisioned by the army.

Reconnaissance flights throughout the pre-D-Day phase grew to represent a crucial element in the overall planning for Neptune, not the least of which was the photographing “of the whole invasion area”.³¹ Pilots flying specially converted Mustangs and Spitfires equipped with powerful cameras provided a wealth of intelligence information for military planners. Their photographs included potential airfield sites, coastal batteries, beach defences and all innumerable military targets.³² Such flights helped to confirm information gathered from the Ultra decrypts, as well as fill in the many blanks. It is difficult to imagine how the Allies could have launched an amphibious assault against the continent without the preliminary work done by photo reconnaissance units such as those in 83 Group.

By January 1944 the spectre of V weapons had come to the fore. Discovered the previous autumn, the threat posed by these sites added impetus to the arming of Typhoon fighters with bombs and rockets in an attempt to nullify them. Codenamed ‘Noballs’, the V1 and V2 sites and their ancillary facilities came under increasing attack by the fighter-bombers almost to the exclusion of other targets.³³ During this period squadrons would be pulled out of the line at the rate of one or two at a time for short periods to undertake further training at Armament Practice Camps.³⁴ As well, during the early months of 1944 squadrons engaged in some joint training with the Army and undertook conversion training as squadrons equipped with older aircraft,

such as the Hurricane IV and Spitfire V, replaced their mounts with Typhoon IBs and Spitfire Mk IXs.³⁵ In addition, a full six Spitfire squadrons exchanged their aircraft for Mustang IIIs (RAF name for American P-51 B and C models) for reconnaissance duties. However, other training tasks were also undertaken which, while taking up valuable time, did little to improve direct/close air support techniques. The most notable was the conversion training of Spitfire pilots to towing and piloting Hotspur gliders. Thomas Koch, a Spitfire pilot with RCAF 401 Squadron, amassed almost 14 hours in 33 trips flying and towing Hotspur gliders, and he was not alone.³⁶ All three squadrons of 126 Wing, 83 Group, 401, 411 and 412, received this type of training, with many 401 pilots acting as instructors. That pilots would be involved in this type of training in the preceding months before D-Day demonstrates the degree of air superiority attained in the Normandy area. This was due in large part to the massive strategic bombing attacks escorted by long range fighters against Germany, that forced the Luftwaffe into the air in defence. It also gives one more indication of how limited a commitment there was to the direct ground support role, a tacit acknowledgment that the RAF would not and could not deliver the kind of close support the army wanted.

To illustrate how far Fighter Command (now divided between 2TAF and Air Defence of Great Britain {ADGB}) had come since the Battle of Britain, the Spitfire, that thoroughbred of Scheinder Racing Cup fame that turned back the Blitz in wheeling aerial combats over London, was equipped with bomb racks and sent on dive bombing missions in the months leading up to the invasion. A Fighter Command

instructional paper to Spitfire pilots clearly indicated fighter pilot sensibilities on the matter: “as time goes on in this war we have been finding that fighter aircraft have been subjected to all sorts of queer roles.”³⁷ Wing Commander Hugh Godefroy, leading 127 Wing of 83 Group was one of those pilots who embarked on this new adventure. In his book Lucky 13, written after the war, Godefroy noted that:

this technique of dive bombing was extremely inaccurate. - The target was to be approached at eight thousand feet. When it was opposite the wing tip, the aircraft was to be turned and dived at an angle of sixty degrees holding the bead of the gun-sight on the target. At three thousand feet a gradual pull-out was to be executed and on the count of three, the bomb dropped. - The bomb should not be released in the dive, only in the pull-out, lest it should hit the prop and blow you all to hell.”³⁸

The sixty degree mark had to be guessed at and as the Spitfire lacked dive brakes the speed of the dive created a lag in the altimeter and blurred the needle as it whirled around, so much so that it was impossible to detect when the 3,000 foot mark had been reached.³⁹ On a mission over France, Godefroy led his squadron against a flak battery and scored a direct hit eliciting the cry of “Sheer unadulterated bullshit luck, Skipper!” from a fellow pilot. Godefroy’s silence signaled his agreement.⁴⁰

A report written in March examining the training and operational effectiveness of fighter-bombers over several months articulated what pilots already knew and previous trials had proven:

In view of the considerable effect that flak has upon operational tactics, it is clear that non-operational training is of only limited value for teaching pilots how to attack heavily defended targets. It is suggested, therefore, that a certain amount of operational training should be undertaken.⁴¹

The report also made note of the importance of using cine-gun film when any attack is made, whether in training or operations, as it allowed for later examination of the attack to assess success or failure and to show where the pilot could improve his technique.⁴² Another point brought out in the report highlighting the difficulty incurred by pilots being retrained from one role to another:

Training methods should emphasize the necessity of releasing the RPs in a smooth dive, to ensure that the 'pull-out technique' as used for dive bombing is not employed with RPs. Release of RP weapons during the pull-out will cause the shooting to be very inaccurate.⁴³

Some fighter pilots, first trained in air-to-air combat, then retrained in dive bombing tactics, were put on course to use rocket projectiles. The rapidity of the transition coupled with the stress of combat resulted in pilots reverting to older, more familiar tactics, resulting in poor performance. As noted above, the report called for the increased use of cine-gun film in order to evaluate attacks and correct mistakes. However, due to problems in installing these cameras in Typhoons, the vast majority of their rocket and bombing attacks went unwitnessed and, therefore, mistakes went uncorrected.⁴⁴

W.A. Bishop became a fighter pilot as his famous father had before him, in World War One. Unlike his father, the younger Bishop found more and more of his targets on the ground, not in the air. Prior to the invasion Bishop noted that he and his squadron mates received "two weeks training for dive bombing - and it was fine until we got over there. When you came in to attack, all this flak was flying at you. It was different from the practice runs and nobody enjoyed it much."⁴⁵ His lament at now

attacking mostly “ground targets” was understandable. Flying a Spitfire such as the Mk IX a pilot had at his control one of the finest air-to-air combat aircraft of the war. It was the Mk. IX that had regained supremacy for the RAF after the Fw 190 had appeared and proven itself superior to the Spitfire Mk V. As Bishop put it, “we didn’t feel like we should be doing dive bombing missions. We felt like we should be looking for the Luftwaffe.”⁴⁶

Considering the weight of the family name, the younger Bishop may have had reason to grouse at being denied the chance to shoot down enemy fighters, but the simple fact of the matter was the Luftwaffe had been all but cleared from the sky along the coast of France. The period of February 20th through the 25th, which came to be known as ‘Big Week’, marked the last major air-to-air battles between the Luftwaffe and the allied air forces, specifically the US 8th Air Force. As part of a new phase of Operation POINTBLANK, American heavy bombers began an offensive against German aircraft production centres. The Luftwaffe sent up large numbers of aircraft to meet the American bombers with their escort of long-range fighters, and suffered grievous losses. For the month of February alone 287 German fighters were lost to the guns of the US 8th Air Force.⁴⁷ In fact, ‘Big Week’ marked not the height of German losses, but the beginning of devastating losses from which Germany had no hope of recovery. The chart below (Table 2.1) indicates the seriousness of the damage done to the Luftwaffe fighter corps in the months leading up to the invasion, and explains why the fighters of 83 Group were in search of new missions in addition to air-to-air combat.

German Fighter Losses January - June 1944 Western Front⁴⁸ (Table 2.1)

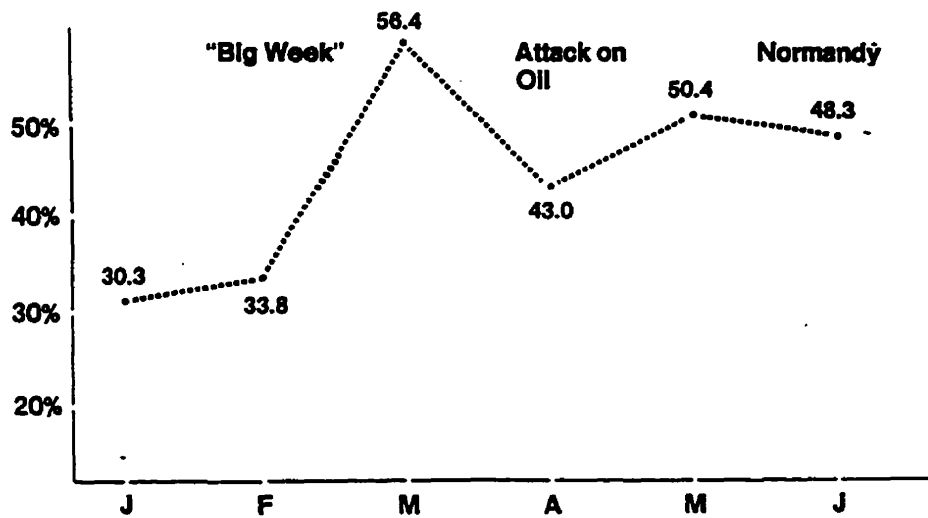

As trials and operations were flown testing various aircraft, weapons and tactics, a parallel development was being pursued that was as equally important to the success of the concept of Army co-operation and direct/close air support. Falling under the military nomenclature 'command and control', 2 TAF struggled with a new component that had been absent from its fighter defence of the British Isles. While fighters were vectored onto enemy aircraft formations through the use of radar in the Battle of Britain, no such technology existed to track ground formations. As long as the army remained in England this was of little consequence to 83 Group flying over enemy territory, because with no ground forces to cooperate with, it could fly as it pleased. However, planners realized this situation would change drastically once ground forces were ashore. The need to coordinate air and ground actions would

become of greater importance. Indeed, the creation of 2 TAF was based on the idea of close cooperation between the two forces, each supporting the other. In Italy this was emphasized by naming the air component the XII Air Support Command. Back in England, however, Fighter Command may have changed names, but it was not about to become a mere supporting arm of the army, as demonstrated by the dissolution of Army Co-operation Command. In fact, not until January 1944 did the RAF accept some form of control of its aircraft from ground forces:

In view of the evidence obtained during the present campaign in ITALY - it has been agreed in consultation with Headquarters Second Tactical Air Force that the principle of visual control of aircraft from forward battle areas should be accepted.⁴⁹

This was to be an extension of the Group Control Centre and ASSU. It was therefore decided that with the agreement of HQ Allied Expeditionary Air Force "trials will be arranged with the object of determining the exact equipment and personnel which will be required."⁵⁰

The value of experience gained in Italy for the Normandy campaign should not be overlooked. The idea that 2 TAF, and therefore 83 Group was a reflection of lessons learned in North Africa is only partly correct. Far more pertinent information was derived from combat experience in Italy, which came closer to approximating the terrain and conditions of Normandy than the North African desert ever could. The Italian experience reinforced the view that fighter-bombers should be "used in the enemy's back areas, beyond the range of our artillery."⁵¹

there may be rare occasions, in terrain approximating to that of the North African desert, when lack of cover enables fighter-bombers to take advantage of targets of opportunity in the enemy's forward areas - **but as a general rule**

they should not be used against gun positions, strong points or fighting troops on the battlefield which can be engaged by artillery.⁵² (my emphasis)

As a result of this combat experience Allied HQ Mediterranean cautioned that “calls for close battlefield support by fighter-bombers should be reduced to the absolute minimum” in order that the air asset can be kept in reserve until sent en masse to attack the enemy’s rear areas thereby isolating the battlefield.⁵³ This operational experience clearly confirmed what the RAF had been arguing all along: air support was best employed far behind the enemy’s lines.

The month of March signified the beginning of the secondary or preparatory phase of the overall air plan. This entailed continued attacks against rail communications, V1 and V2 sites, German airfields in the Normandy area, coastal batteries and naval installations.⁵⁴ Attacks against radar stations were to begin in May just one month before the invasion so that there would be insufficient time to repair the installations.

April marked the beginning of pre-invasion attacks, and targets previously restricted from attack were now authorized. For the fighter-bombers of 83 Group this meant bridge busting. In a letter to Portal in April 1944, Slessor commented on the suitability of the bridge as a target for medium and fighter-bombers: “I hope the value of the bridge as an objective in attack on communications is thoroughly realized by the Tactical Air Forces in U.K. - it is something rather new since Tedder’s day out here.”⁵⁵ As we have seen the lessons of the Italian campaign were making their way through to England, but it is also clear that 83 Group was discovering for itself what targets could

be hit accurately. A report written in May questioned the suitability of the bridge after studying data from several attacks:

A 50 per cent zone of 400 yards is not too unsuitable for area targets; but hopeless for the small targets that are so vital in army support work. Many hundreds of sorties would be necessary to make sure of hitting a bridge when the scatter is so large. Instead, something like 100 yards is needed, to keep the sorties down to a reasonable number. Even then there must not be too few if it is an important target. This accuracy is obtainable by good pilots, both in dive bombing and in level bombing with the right sight; but it needs more practice than we have had...⁵⁶

A report at so late a date signaling the inability of pilots to hit small targets would have been shocking to the Army but the AEAFF continued to promise its support on the battlefield and Montgomery either blithely accepted this, or was cognizant of the difficulties but determined to proceed regardless. It is hard to understand the gulf between the air and ground forces as memoranda continued to circulate noting such difficulties.

The May 1944 draft report on Army Air Co-operation for the upcoming campaign in Normandy was quite clear: "The proper function of bombers of all classes is to prevent or interfere with movement of reserves, fuel, ammunition, rations, and warlike stores generally."⁵⁷ The report also stated that in the assault phase "close battlefield support by fighter-bombers should be reduced to absolute essential minimum, so that they may be concentrated at the critical time against enemy movement where it is important - in his immediate back areas where reserves and supplies may be expected to move."⁵⁸ Written in this way the RAF indicated that it could best serve the Army by pursuing its own battle plan - one that would not directly assist the Army,

something it had consistently argued since the end the First World War. Instead of admitting to the Army that it was unable to assist it as the army desired, the RAF instead argued that interdiction was a more useful role than direct/close air support.

By May additional targets were attacked by the fighter-bombers of 83 Group including radar stations along the coast and airfields in and around Normandy as well as increased attention given to rolling stock and locomotives. The radar sites proved both difficult to hit and heavily defended by flak emplacements, resulting in heavy losses to fighter-bombers. Additional targets were railway key points and road communications, coastal batteries, airfields in active use and 'CROSSBOW' targets, V1 launch sites and affiliated facilities.⁵⁹ At the meeting when these targets were selected, intelligence reports were discussed indicating "no general move of German fighters from GERMANY to the West has taken place"⁶⁰ The invasion was just days away and Ultra had confirmed what fighter sweeps had been indicating for months, the Luftwaffe was no longer believed to be a serious threat. In light of this information, one should consider the makeup of 83 Group. The vast majority of its squadrons were made up of air superiority fighters. With the need for maintaining air superiority reduced, the preponderance of fighters trained primarily in escort duty makes it clear why the RAF focused on tactics away from the battlefield. In short, 83 Group was equipped and prepared to support the army in a land campaign on the continent through the 'gaining and maintenance of air supremacy'. Flowing logically from that initial policy came the deployment of fighters and fighter-bombers to armed reconnaissance and interdiction missions behind German lines, in an attempt to isolate

the battlefield and destroy and/or disrupt the supply and reinforcement of German front line positions.

Seemingly oblivious to the RAF's inability and unwillingness to offer the kind of close support the army desired, General Montgomery proceeded apace, all the while extolling the virtues of close relations. In a memorandum Montgomery sent to his senior ground commanders (Dempsey, Crerar, Bradley and Patton) in May 1944 he rather belatedly noted that "there is a definite gulf in England between the armies and their supporting air force." As a way of improving this situation, Montgomery suggested that they "get to know each other, and get that understanding of each other's problems which will be the firm foundation of mutual confidence and trust when we begin fighting."⁶¹ Montgomery went on to list a series of points he felt were crucial to the endeavour. Perhaps most critical was that "the two HQ, Army and Air, must be side by side, or adjacent." Uncharacteristically, Montgomery included the following statement:

I feel very strongly on the whole matter, and I know that we can achieve no real success unless each Army and its accompanying Air Force can weld itself into one entity. There is much to be done and not too much time in which to do it. We must not merely pay lip service to a principle we must put into practice the actual methods that will achieve success.⁶²

In fact Montgomery himself had made sure that such a close working relationship did not develop in his refusal to meet with Coningham and insisted on dealing directly with Leigh-Mallory. One must keep in mind, however, that even if the various commanders involved had developed a close working relationship the basic problems of close air

support would remain - finding and hitting a target in a fast moving single seat fighter designed for air-to-air not air to ground combat.

After almost one year of existence, 83 Group prepared to embark on a new and relatively untested mission, the support of ground forces engaged in land operations on the continent. The success of the invasion was far from the certainty now perceived over half a century later. The vulnerability of Allied forces, first in the English Channel and then on the beaches, was deemed severe, and consequently the role to be played by 83 Group was. It was to this task, the protection of the invasion forces, that the tactical air force now turned its full attention in the third act of the Overall Air Plan, the Assault phase, D-Day.

End Notes to Chapter Two

¹ British Official History The Liberation of North West Europe, Air Historical Branch, 1947, p 13. AIR 41/24 169523

² Ibid. AIR 41/24 169523 p 12.

³ Air Support and Air Reconnaissance Aspects of Combined Operations in NW Europe, June 1944 - May 1945, Air Historical Branch. Chapter One, General Review, p 6.

⁴ Jerry Scutts. Typhoon/Tempest in Action. p 32.

⁵ AIR 41/24 169523 p 13.

⁶ Christopher Shores. 2nd Tactical Air Force. p 2.

⁷ W.A. Jacobs. The Battle For France, 1944, p238.

⁸ Jacobs. Ibid, p 242.

⁹ Terraine. p 637.

¹⁰ Training Syllabus Summary of Flying Training Exercises - Single Engined Ground Attack Pilots (Typhoon) p 1. AIR 16/493

¹¹ Fighter Command Tactical Memorandum No. 30 "Artillery Positions as Targets for Army Support Aircraft"

¹² In his book The Brigade, Terry Copp notes just how limited training opportunities were between air and ground formations. Not until February 1944 did 5 Brigade of Cdn 2 Inf Div have an opportunity to train with elements of 2 TAF and then only briefly. British formations fared no better. p 39.

¹³ 83 Group Intelligence Summary Reports 1943 - 1944. Contained in the Papers of Squadron Leader R.T. Wilkins, IWM Collection, 83/15/3.

¹⁴ Memo on Air Aspects of Operations as it Affects 21 AG, October 1943. WO 233/24 155624

¹⁵ Air37/1237 xc 154927 p2

¹⁶ WO233/24 155624 Memorandum on the Air Aspect of Operations as it Affects 21 Army Group, 6 October 1943, p 2.

-
- ¹⁷ ORS Assessment of Attacks on Small Targets by Fighter Type Aircraft, 20 May 1944. AIR 37/497 xc00019
- ¹⁸ ORS (ADGB) Report No. 41 Operational R.P. Tactics 30 March 1944, p 3. AIR 37/497 xc155046
- ¹⁹ ORS/AEAF Report No. 16, "The Accuracy of Attacks on Small Targets by Fighter-Bombers and R.P. Fighters" 10 June 1944.
- ²⁰ AIR 37/497 xc155046 p 4.
- ²¹ ORS (FC) Report No. 501. "RHUBARB" Operation - Results achieved and losses suffered January - July 1943 12 October, 1943, p1. AIR 16/1044 136304
- ²² Ibid. AIR 16/1044 136304
- ²³ Ibid. AIR 16/1044 136304
- ²⁴ Air Historical Branch. The Origins and Development of Operational Research in the Royal Air Force, p 136.
- ²⁵ Air Historical Branch. Air Support and Air Reconnaissance Aspects of Combined Operations in NW Europe, June 1944 - May 1945, p 7. WO 233/61 7225
- ²⁶ Ibid. WO 233/61 7225 p 6.
- ²⁷ Ibid. WO 233/61 7225 p 7.
- ²⁸ AIR 37/497 xc155046 p 6.
- ²⁹ Report on Air Attacks on Locomotives September 12, 1943, HQ 2TAF. AIR 37/826 168868
- ³⁰ Ibid. Air 37/826 168868
- ³¹ AIR 14/24 169523 p 14.
- ³² Ibid. AIR 14/24 169523
- ³³ Tactics used by Typhoon Day Fighter/Bomber Squadrons of 2nd TAF p 1. AIR 37/835
- ³⁴ Shores. 2nd Tactical Air Force, p 6.
- ³⁵ Ibid. p 7.

-
- ³⁶ Robert Bracken. Spitfire: The Canadians. p 75.
- ³⁷ The Use of the Spitfire-Bomber (Bombfire) HQ Fighter Command, Air Tactics, March 16, 1943, p 1. A5218 598
- ³⁸ Hugh Godefroy. Lucky 13, p 237.
- ³⁹ Ibid.
- ⁴⁰ Ibid. p 238. See also Bill Olmsted's Blue Skies: The Autobiography of a Canadian Spitfire Pilot in World War II. Toronto: Stoddart Publishing, 1987. "In our role as dive bombers we were forced to use a trial-and-error method, for we had no special apparatus to aid us in aiming our bombs." p 179 .
- ⁴¹ AIR 37/497 xc155046 p 2.
- ⁴² Ibid. AIR 37/497 xc155046
- ⁴³ Ibid.
- ⁴⁴ Ibid. p 3.
- ⁴⁵ Bracken. Spitfire: The Canadians. p 79.
- ⁴⁶ Ibid. p 80.
- ⁴⁷ William Hess and Thomas Ivie. Fighters of the Mighty Eighth. p 64.
- ⁴⁸ Williamson Murray. Luftwaffe. p 227.
- ⁴⁹ Air Co-operation with Armoured Formations HQ 21 Army Group, 19 January 1944. WO 205/535 114125
- ⁵⁰ Ibid. WO 205/535 114125
- ⁵¹ The Employment of Bombers and Fighter-Bombers in Co-operation with the Army, Allied Forces Headquarters, May 6, 1944. AIR 2/7870 113691 p 6.
- ⁵² Ibid.
- ⁵³ Ibid. p 7.
- ⁵⁴ AIR 41/24 169523 p 14(a).

⁵⁵ Terraine. p 587. (as quoted from Slessor)

⁵⁶ Report by Group Captain Harvey, ORS/AEAF 2 May 1944.

⁵⁷ Draft Employment of Bombers and Fighter Bombers in Cooperation with the Army
6 May 1944. p 10. AIR 20/3213

⁵⁸ Ibid. AIR 20/3213 p 11.

⁵⁹ BIGOT Notes on Stanmore Meeting No. 4, 31 May 1944, p 4. AIR 37/1126

⁶⁰ Ibid. AIR 37/1126

⁶¹ Memorandum sent to Generals Dempsey, Crerar, Bradley and Patton by General
Montgomery, May 1944. AIR 37/1237 xc 154927

⁶² Ibid. AIR 37/1237 xc 154927

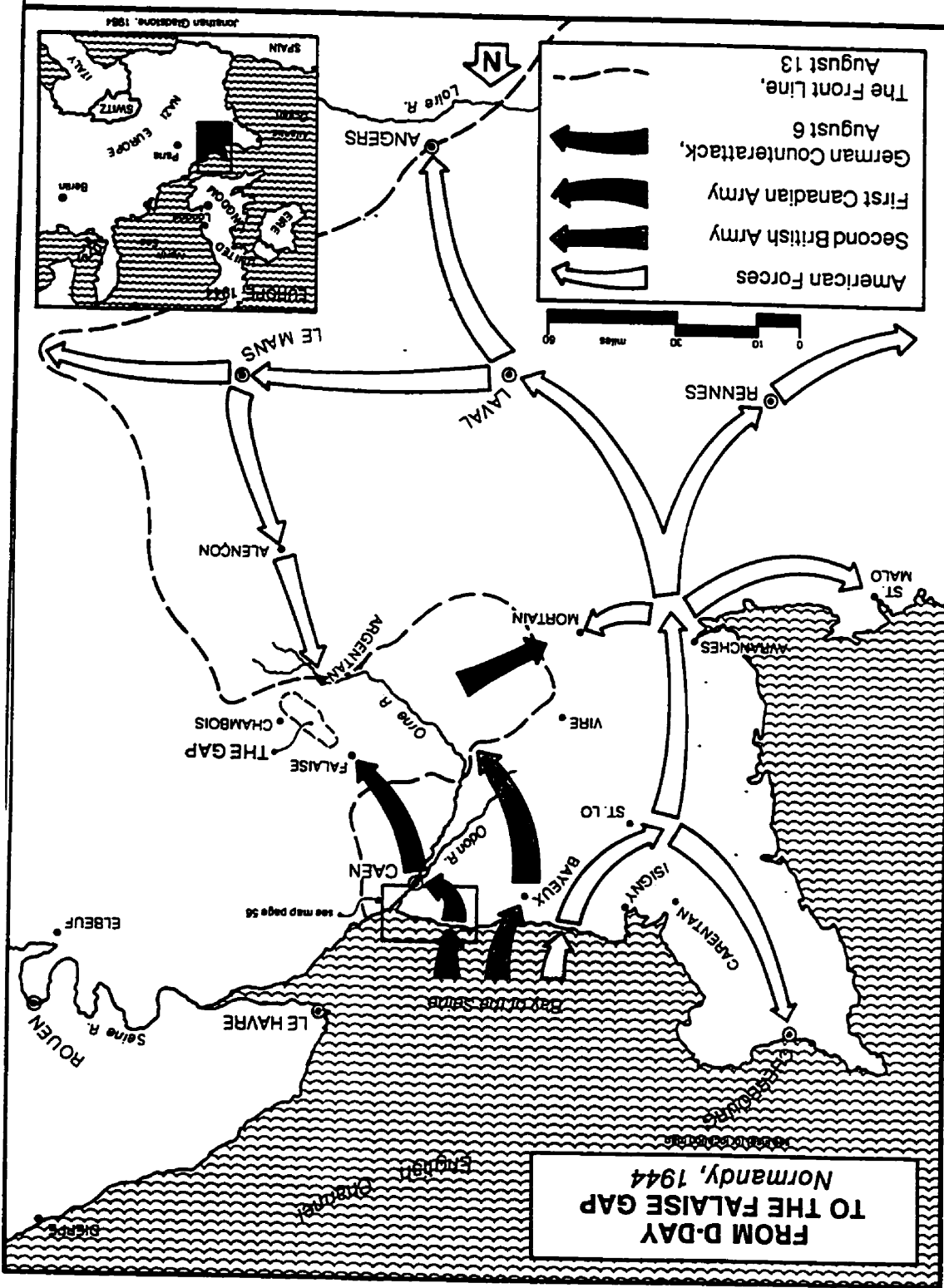

The Normandy Campaign (Fig. 3.1)

Four years after their ignominious retreat from the European continent the Allies prepared to return in what would be the greatest amphibious invasion in history. Many things had changed in the intervening years to make an invasion possible. The British and Canadian armies were now joined by that of the United States and the bulk of the German forces were enmeshed in the war with the Soviets. Numerically, the Allies enjoyed a sizable advantage on land and sea and an overwhelming one in the air. By the summer of 1944 Germany was on the defensive in every theatre of war and the prospect of an Allied victory that year, whether on the eastern or western front, was considered, albeit quietly. However, for the western Allies the first of many hurdles in the path toward that goal was the successful crossing of the English Channel and capture of a beachhead on the continent. Just as German planners had concluded before them, Allied commanders considered air superiority crucial if the assault was to have a chance of succeeding. One major component in ensuring that goal was the creation of 83 Composite Group within the Second Tactical Air Force in the summer of 1943.

Composed almost exclusively of high performance single engine fighters, 83 Group was to provide air support to the ground forces in both defensive and offensive roles. The first and foremost among these was the 'gaining and maintenance of air superiority' over the battle area. As this thesis has shown that goal had largely been achieved by the summer of 1944, yet as D-Day approached the need to ensure that this hard-won superiority was not squandered meant a high percentage of sorties were still

tasked with air supremacy; the tempting target about to cross the channel made this imperative.

In this chapter the conduct of operations in the Normandy campaign will be examined. This refers to the period of D-Day through to the closing of the Falaise Gap. Thus far this thesis has examined the development of a tactical air power doctrine in the British military in North West Europe and the efforts expended in developing the men and machines to implement its use. On June 6, 1944, those efforts were put to the ultimate test as the combined western allied armies came ashore in Normandy and engaged the German army in combat. Ranging above and beyond the battlefield the fighters and fighter-bombers of 83 Composite Group strove to make the contest as uneven as possible.

Two potential crises were anticipated by the planners during the assault phase, the crucial period when the troops began to come ashore, and the expected enemy counterattack with massed armour.² The reserves that the German Army could rush to the assault landings were believed to comprise 9 panzer and panzer grenadier divisions and one infantry division. A report circulated in February 1944 examined the timetable for these German divisions to be moved to the battlefield after D-Day. Four were expected to move by road, four entirely by rail and the final two using a combination of both. The report concluded that with no interference and a complete failure of the deception plan to convince the Germans that the Pas de Calais was the main landing site, all divisions could be expected to reach the battle front by the afternoon of D+4.³ In each case air superiority was deemed vital to ensure that the

Luftwaffe could not disrupt Allied ground forces at their most vulnerable moment and, at the same time, inhibit the movement of the German forces. To that end Leigh-Mallory as Air Commander in Chief of the AEAFF allocated his vast fighter resources to the dual task of defending the assault forces, and interdicting the enemy. They were supremely suited to carry out the first task.

The Overall Air Plan had originally called for 100% effort by the air forces on 1 and 2 June, with a decrease of 50% for 3 and 4 June “so that maximum force could be ready for the Assault [5 June].”⁴ However poor weather altered the original plan. On June 1 far less than 100% effort was expended. The next day saw weather conditions improve but again less than 100% effort was possible. 50% effort was achieved on June 3 as planned as radar installations, coastal batteries, bridges and railway targets were attacked.⁵ That night General Eisenhower made the decision to postpone D-Day until June 6, citing the fact that while the air forces enjoyed an overwhelming majority the land forces did not. Noting that the invasion was only possible with such air superiority he concluded that “if the air could not operate then it [the invasion] must be postponed.”⁶ Eisenhower understood how extremely vulnerable the Allied forces would be in the assault phase and would not risk them without the protective shield of the air forces. It should be understood here that this protection could be provided only in one form, the single engine fighter. Not since the Battle of Britain had the men and machines of the RAF’s fighter squadrons been faced with such an important task.

On 4 June, originally planned as 50% effort, additional operations were added resulting in more attacks on coastal batteries in the Pas de Calais as the cover plan was

still in effect. On 5 June, the original date for D-Day, there was a further increase in the number of sorties flown. The Typhoons of 83 Group spent the entire morning attacking radar stations along the coast and then switched to attack various German Headquarters buildings further inland.⁷

Taking off from England in the dawn on June 6, 1944 the pilots of 83 Group flew towards the coast of France in aircraft freshly painted with black and white recognition stripes on their wings and fuselages.* Despite this precaution and a ban on firing unless directly under attack, naval anti-aircraft fire repeatedly shot at friendly aircraft.⁸ The 12 Spitfire squadrons of 83 Group were assigned low fighter cover between 3,000 and 5,000 feet over the beaches on D-Day during daylight hours along with 15 squadrons from 84 Group and 9 squadrons from ADGB.⁹ 122 Wing of 83 Group, equipped with the Mustang III, was assigned to the Readiness Pool of some 30 squadrons to be kept in reserve should the Luftwaffe mount an all-out onslaught at some point. As the day wore on and no attack was forthcoming, 122 Wing was released and flew escort missions for Coastal Command and transports carrying airborne troops to the battle area on D-Day, a relatively uneventful day.¹⁰ For the

* In the final few days before the invasion allied aircraft were over painted with a series of large black and white stripes. Their purpose was to provide quick recognition to both allied anti-aircraft crews as well as other allied fighters in order to minimize friendly fire incidents. Their success was questionable as numerous aircraft were lost or damaged due to friendly fire, one account in particular noting that "German striped planes were either attacked by Allied fighters - or met terrific cones of ack ack fire". (see Maple Leaf Up - Maple Leaf Down by Peter Simonds, pg 164.) In fact these aircraft were almost certainly allied. In fact it became necessary to curtail sorties over the beaches at dawn and dusk as the number of friendly fire incidents was quite high. In just one 2 ½ hour period on June 9 14 allied aircraft were shot at by allied flak off

Spitfire squadrons of 83 Group, the first day proved to be similar. Working in shifts, one Wing consisting of 3 squadrons would fly to the coast and take up position over the assault areas in the Anglo/Canadian sector, keeping up a non-stop coverage over the landing forces. This resulted in 4 squadrons patrolling the centre of the assault area with one on either flank for a total of 6 on Low Cover.

Fighter Patrol Areas on June 6, 1944¹¹ (Fig. 3.2)

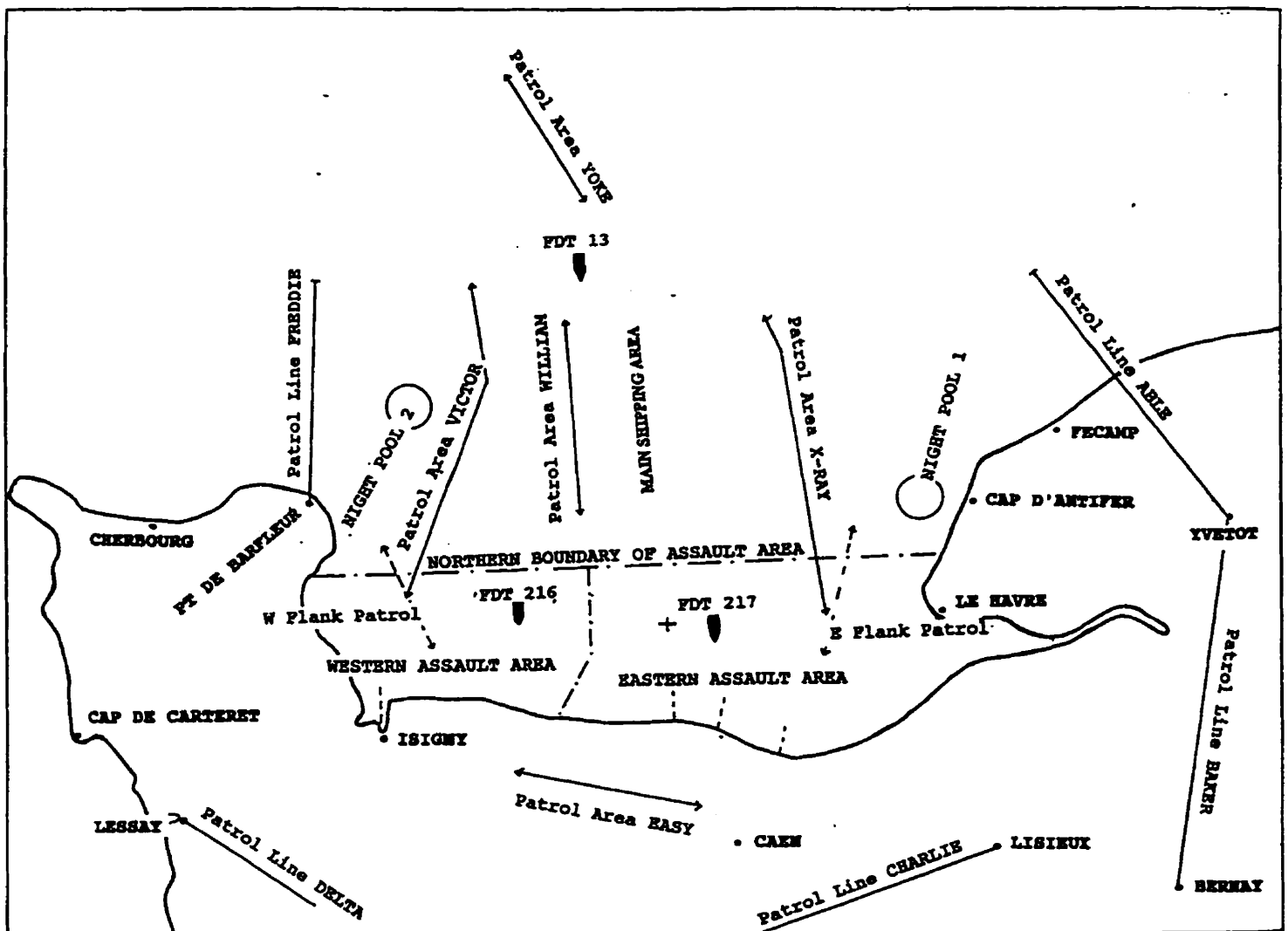

of Utah beach. 3 were destroyed and several more damaged. See AEAFF Official History, p 52.

In order to direct the huge numbers of fighters that would be flying throughout the opening phase, a form of decentralized control was devised to ease the burden on AAEAF HQ, and was set up at Hillingdon House near Uxbridge under the command of Air Marshal Coningham. Known as the Combined Control Centre it used the existing Fighter Command/ADGB infrastructure to oversee all fighter squadrons. As the fighters approached the far shore, however, a new component was to come into play, the Fighter Direction Tender (FDT). Converted from landing ships - tanks, these ships were, in the words of one serving aboard them, “ungainly - radar aerials like revolving chicken coops, RDF [radio direction finding] beacons, antennae”.¹² Three were built and allocated, one each for the Western and Eastern assault forces, with the third being stationed some 40 miles off the beach in the shipping lanes.¹³ (See Fig. 3.2) As it turned out, there was no Luftwaffe presence to speak of in the daylight hours, and with the establishment of 83 Group’s Control Centre in Normandy by the evening of D-Day, the FDTs instead focused on control of night fighters over the beachhead and English Channel.

While the Spitfires and Mustangs provided defensive air cover and escorts, the Typhoons were employed in offensive strikes in aid of the ground forces. Of the 18 Typhoon squadrons in 83 and 84 Group, 12 were given pre-arranged tasks for the morning. Nine were allotted to the British/Canadian sector, one per beach with the other six rotating throughout the day. These were on air alert and controlled by the respective HQ ship for each beach. The squadrons had already been briefed on targets to attack, “but were instructed to call up the HQ ships on arriving at the assault

area in case the Assault Force Commanders required them to take on more urgent targets.”¹⁴ The other 9 squadrons had pre-arranged targets further inland. Receiving no instructions from the HQ ships the Typhoons bombed their first targets, strong points at Gold, Juno and Sword beaches.¹⁵

As the day wore on the Typhoons were then released to fly armed reconnaissance missions south of the line Bayeux-Caen-Lisieux.¹⁶ D+1 witnessed the same intensity of fighter cover over the Assault area, which was to provide a huge dividend. Two formations of enemy aircraft sent to bomb the beachhead were intercepted before they could attack, thereby almost certainly averting heavy casualties among ground and naval forces. 83 Group fighters claimed 14 enemy aircraft with a loss of 16, but 10 of these were Typhoons brought down on ground attack missions.¹⁷

Concern over the movements of German armoured divisions to the battle area prompted the decision “to intensify armed reconnaissances by 2nd TAF fighter-bombers in order to harass enemy movement towards the beach-head.”¹⁸ For 83 Group this meant the 10 Typhoon squadrons “were assigned to the quadrilateral from Caen to Mezidon Railway junction thence to Falaise and to the road fork south of Villers-Bocage.”¹⁹ They were also instructed, however, to call up HQ ships as they passed over the coast to see if they were needed more urgently somewhere else.

In the early stages of the campaign the RAF’s preferred method of air support was being applied, and with good reason. The lack of close support targets meant the numerous fighter-bomber and fighter squadrons were able to perform the task the air force had argued for from the beginning, defensive patrols and armed reconnaissance

far beyond the front lines, seeking to interdict air and road movement towards the front, a task which they were eminently better suited.

Despite bad weather the sorties went ahead and pilots reported that now there was considerable road movement toward the front. Two missions past the beachhead were in fact diverted in the morning to attack road movements of trucks and tanks. Of the sorties flown that day by 2 TAF the vast majority, over 700 sorties out of 752, were armed reconnaissance.²⁰ 83 Group dropped 307 bombs and fired 1,321 R.P. resulting in claims of 6 tanks, 79 MET and 14 enemy aircraft destroyed. The following day saw little improvement in the weather and this, combined with a lack of suitable targets and little Luftwaffe opposition, resulted in a decline in sorties flown.²¹ Nonetheless, the number of calls for support by the army increased, and Typhoons of 83 and 84 Group flew 80 close air support sorties on June 8. More calls for air support were received as the ASSU's came ashore, and Allied units came up against ever increasing resistance. Responding to the heavy traffic moving towards the front from the east, the Typhoons quadrilateral was cut to the triangle Caen-Lisieux-Falaise, while longer range Mustangs were allotted the more distant target areas. That evening it was reported that elements of 21 Panzer, 12 SS and the Panzer Lehr Division were in the line opposite 2nd British Army.²²

By 9 June, D+3 the allies had linked all five beachheads and had brought enough reinforcements ashore to provide a secure defence against German counterattacks, particularly since the forward lines were within easy range of naval guns. The tactical air forces now truly confronted the challenge: in addition to providing air cover,

intelligence, interdiction of the movement of German units and supply, they were to fly more missions in direct or close support. It is from here that the myths, controversies and recriminations over this aspect of air support has muddied the debate on tactical air power in the Normandy campaign. A closer look at the various mission types would be useful at this point.

Air Superiority

The generally accepted concept of air superiority is

that degree of dominance in the air battle of one force over another which permits the conduct of operations by the former and its related land, sea and air forces at a given time and place without prohibitive interference by the opposing force.²³

However, the simplicity of the statement belies a complex implementation:

The fight for air superiority is not a straight forward issue like a naval battle or a land battle; it is not even series of combats between fighters; it is frequently a highly complex operation which may involve any or all types of aircraft. It is a campaign rather than a battle, and there is no absolute finality to it so long as any enemy aircraft are operating. [-] I think that one reason why people have found it difficult to understand is that it is most effective when the operations to secure and maintain air superiority are not visible to those who are benefiting from it.²⁴

In the Normandy campaign the German Air Force continued to fly in such numbers that despite Allied numerical superiority the maintenance of air superiority remained a constant and, as this thesis will argue, vital role in the support of ground forces.

By D-Day air superiority was believed to be well in hand but required constant attention to maintain. Air Marshal Tedder commented after the war without bravado that “even though one ‘felt’ the air situation was satisfactory one must admit to a certain degree of anxiety - it would have needed only a small surviving enemy force to

do immense damage during the initial landings.”²⁵ To prevent such attacks the tactical air forces continued attacks on Luftwaffe airfields and infrastructure, escort patrols for bomber and fighter bomber formations, defensive patrols over the sea and land forces and offensive sweeps behind enemy lines to search out and destroy enemy aircraft.

The maximum effort that the Luftwaffe was expected to put up on D-Day was estimated at 1,250 sorties for all types of aircraft. Shortly thereafter the ultimate number of sorties for one 24 hour period was calculated at no more than 1,750, with this number expected to fall rapidly thereafter. Staff at AEAH HQ became more and more skeptical that the Luftwaffe could attain even these relatively small numbers as D-Day approached.²⁶ An Allied intelligence estimate of Luftwaffe strength submitted in May 1944 calculated a total of 5,250 aircraft on all fronts. Of these approximately half, 2,350, were stationed in the Western Front. The report cautioned that while these numbers were larger than previously estimated, the “low fighting value and operational inefficiency of the G.A.F. - with a correspondingly far greater increase in the strength and quality of the G.A.F.s opponents” meant the Luftwaffe was a mere shadow of its former self, no longer able to sustain intense combat operations for more than a short span of time, and only with dire consequences to pilot and aircraft numbers.²⁷ In all of France, only 335 long range bombers, 70 fighter bombers, 210 single engine fighters, 210 twin engine fighters, 55 long range reconnaissance and 45 tactical reconnaissance aircraft were stationed.²⁸ Of this number, 900 aircraft were considered likely to be available to attack on D-Day, and only 220 of these were single

engine fighters.²⁹ Reinforcements likely to be made available were calculated as follows:

Estimate of Luftwaffe Reinforcements to reach Normandy³⁰ (Table 3.1)

	L.R.B.*	F.B.	S.E.F.	T.E.F.	Total
D Day to D+1	110		90	30	230
D+1 to D+4	90	50	140	20	300
Total	200	50	230	50	530

* Mainly anti-shipping units.

The Allies had broken most of the German Air Force Enigma keys by February 1944 and so were able to closely monitor that organization.³¹ The vast Allied air armada assigned to defend the ground and naval forces assembled in the English Channel might therefore seem excessive, but the prudent course of action was still the protection of the assault forces at all costs. Despite the vociferous recriminations that have echoed ever since Dieppe, that failed raid did provide some important lessons. Dieppe illustrated the need for overwhelming firepower both at sea and in the air once the element of surprise had been exhausted. On June 5 Allied commanders lacked the confidence of so many historians when they describe D-Day in retrospect. Allied commanders knew that there was the very real possibility of the assault being thrown back into the sea. Had that tragedy come to pass the air superiority of the allies would have been crucial in pinning down German ground forces and protecting the withdrawing forces at their most vulnerable.

During the period June 6 through June 30, 1944, despite over 5,000 vessels of all types being in a small confined area losses caused by the Luftwaffe amounted to a mere 5 vessels sunk and 7 damaged.³² The vulnerability of infantry and armour in

ships was absolute before they reached the shore, yet the Luftwaffe was prevented from wreaking havoc upon them. The reason was clear, as noted in the diary of at least one sailor aboard ship: "We have overhead a continual screen of fighter aircraft. It is a grand sight to see them wheel and chase off any enemy aircraft that dare to come over."³³ The largest ship sunk was a destroyer which was insignificant to the land battle being waged. Far more important targets such as battleships with 16-inch guns able to directly intervene in battles miles inland were entirely unmolested by the Luftwaffe. On D+2 this inability had resulted in a complete route of a German counter-attack against Canadian forces:

The enemy had systematically hacked an element of the Panzer-Lehr Division to pieces with heavy artillery. Beside the obliterated vehicles and weapons lay the pieces of our Comrades. Others hung from trees. It commanded a dreadful silence.³⁴

As long as the fighting remained within range of the big guns any German counter-attack was at dire risk of being caught in the open by their huge shells. Without a credible threat from either the Luftwaffe or Kriegsmarine, the German army was at the mercy of these weapons and unable to prevent the reinforcement of the beachhead.

The archive of a German maritime attack squadron illuminates just how critical this was:

The enemy could, because of his air supremacy, strike at our key industries and road and rail transportation systems and vehicles. We were unable to attack the enemy's key industries. But the enemy could make use of his key industries only when they were delivered to the battle area. Thus, for us, the enemy's key industries were his supply ships. The shipping fleet was a concentration of key industry. It was attackable by us. Only there could the enemy be grievously hit.³⁵

Intelligence

The fourth fighter type operated by 83 Composite Group were the Allison powered Mustangs.[†] The Mk I and IA Mustangs despite unsatisfactory performance at high altitude equipped 3 of the 4 squadrons in 83 Group's No. 39 Reconnaissance Wing. These fighters were tasked with low and medium altitude tactical reconnaissance missions well beyond the battlefield. They found little road movement that first morning and so were unable to provide targets for the Typhoons later in the day. Nonetheless their reconnaissance missions were of the utmost importance, and were used to search out German reinforcements, especially armoured units. While Ultra decrypts provided much information they took time to decode and disseminate whereas tactical reconnaissance by fighters was virtually instantaneous. In general

they [reconnaissance] kept a general watch on road and rail movement and on shipping; they flew over rivers to observe barge movement; bridging and ferrying sites; they made detailed searches of specific areas at the request of Twenty-One Army Group to detect possible concentrations for counter-attacks. They also carried out intelligence missions in search of gun-sites, dumps, supply centres, etc., and for purposes of bomb damage assessment.³⁶

Tactical reconnaissance focused on areas on and relatively near to the front line and involved both "visual and photographic" searches by pilots, often flying singly or in pairs.³⁷ Strategic reconnaissance was performed in 83 Group by the composite squadron of 39 Wing, of Spitfire and Mosquito photo-reconnaissance aircraft. These aircraft flew exclusively at high altitude, deep behind enemy lines and provided intelligence directly to the highest command levels.³⁸

One measure of Tactical and Strategic Reconnaissance utility is reflected in the sheer volume of photographs generated by their missions which were then distributed widely, often down to the platoon level.

Production of Air Photographs by 83 Group during the Normandy Campaign³⁹

Month	No. of Successful sorties	No. of Exposures	No of prints
June	446	34,000	287,000
July	299	33,000	380,000
August	495	76,000	814,000
Totals	1240	143,000	1,481,000

(Table 3.2)

However dedicated reconnaissance squadrons such as those in 39 Wing were not the only aircraft engaged in the gathering of intelligence on German ground dispositions.

It was expected that “aircraft carrying out other tasks”⁴⁰ would also note and report back any useful information they observed:

So frequently are fighter aircraft operating over the forward enemy localities that fighter pilots rapidly develop a considerable knowledge of the enemy ground situation. Information gained from combat, bombing, or ground attack sorties is a useful supplement to tactical reconnaissance, and a reliable alternative to it when tactical reconnaissance is restricted.⁴¹

Armed Reconnaissance and Interdiction

Stated simply armed reconnaissance meant “fighter aircraft are sent out to look for ground targets and attack them. At the same time, pilots bring back any possible information about the enemy ground situation.”⁴² Missions would have anywhere

[†] The Mustang Mk I, IA and II were equipped with the Allison 1,150hp and 1,120hp engine in the II. The Mustang III and IV however, were powered by the Merlin

from 4 to 12 aircraft “sweeping the given area at a height of about 4,000 to 6,000 feet, according to the flak concentrations present, and searching for any form of road, rail or water-borne movement.”⁴³ This, of course, entailed flying behind enemy lines. It is important to note that these missions were carried out primarily by fighter not fighter-bomber aircraft, as the potential of encountering enemy aircraft grew, the further one flew behind enemy lines.

Interdiction “was usually carried out in a fairly calm period before the land battle really joined, and consisted of cutting off completely the area in which the enemy was situated by carrying out bombing attacks on all lines of communication leading to the area.”⁴⁴ Armed reconnaissance missions were therefore an integral part of the interdiction campaign.

The problem in assessing the effectiveness and therefore the contribution made by tactical air power in the interdiction of the battlefield in Normandy resides in the nature of the weapon; it attacks with speed from the air, and then is gone. Pilot claims of destruction were difficult to verify, gun cameras recorded only a fraction of all attacks and then at several hundred miles per hour in less than steady flight. Through POW reports, however, some glimpse of what interdiction achieved is possible. One such report filed during the campaign clearly indicated the extreme measures the German army was forced to undertake in the face of continued allied air attack.

- i) In most areas side roads are used exclusively, and one P/W says the use of main roads is expressly forbidden. A Major alleges that the use of secondary roads and country lanes has prevented the complete breakdown of supplies which would have resulted had any attempt been made to

I,680hp engine and were used in a fighter role. Eyes of the RAF, Nesbit, p 191.

continue the use of main roads. Side road traffic, he believes, is satisfactory where the time factor is not critical.

- ii) The interval between vehicles is 100 to 200 yards, sometimes more in day time and less at night.
- iii) Movements are almost exclusively carried out at night because of the comparative freedom from air attack.
- iv) The side roads to be used are scouted by a small party on the day before the night of the projected move and the route is laid accordingly.
- v) Air lookouts are posted for, aft, and if possible on the flanks of convoys and troop columns. These look-outs are equipped with portable R/T.
- vi) When the watches report and attack as imminent an attempt is made to draw vehicles into the side but there is seldom time for this and personnel usually scatter immediately on receipt of the warning leaving their vehicles standing.
- vii) There are no fixed times of halt and rest.⁴⁵

While it is clear that the ability to move by night and during inclement weather eased the burden, it is equally clear that the threat of constant air attack was a hindrance to the movement of men and materiel, and therefore aided in the victory in Normandy.

In his article 'Tactical Air Power in Normandy: Some Thoughts on the Interdiction Plan' Robert Vogel notes this difficulty, although he ascribes "the complicated nature of the German response" as the primary problem.⁴⁶ Whatever the case the fact remains that it is impossible to quantify the contribution made by air power to isolating the battlefield. German commanders, however, were far less circumspect in citing the Allies' overwhelming air power as the cause of their delays, but again Vogel cautions that by laying the blame on the Luftwaffe, not controlled by the army, the Generals could not be faulted for the loss.⁴⁷ Vogel also examines some of the movements of German forces after D-Day as they made their way to the battlefield. Through German records he determines that many units reached the front lines safely despite the massive effort of the Allied tactical air forces to prevent them from doing so.⁴⁸

Another factor that was a serious hindrance on German movement seems to have been unwillingness to retreat from the range of Allied naval guns. In addition, Vogel points out that the German 7th Army in Normandy was chronically under-supplied during the campaign, but questions how much of this was due to interdiction versus the lack of motorized transport and fuel, as experienced on every front by the summer of 1944.⁴⁹ Vogel also chronicles the movements of several Panzer and Infantry units to the Normandy battlefield, discovering that many were able to move with little or no interference from the air. For the entire month of June, 83 Group claimed only 552 MET destroyed and another 468 damaged which, taking into account the likelihood of inflation, would seem to support his conclusion.⁵⁰

Direct or Close Air Support

Reflected in the dichotomy of views between the army and the RAF on what form air support should take, the general term 'direct air support' was used as a catch all to describe "the attack by air forces of targets having an immediate effect upon the action of our own land forces and may be divided into prearranged and impromptu support."⁵¹ This support was primarily but not exclusively concerned with ground attack, which entailed a combination of strafing, bombing and/or rocketing of specific targets near the front line. Prearranged targets were chosen in advance, whereas impromptu targets were those that the pilots were vectored onto while in flight.

For missions on the battlefield, and therefore near allied troops, a communication system had been developed based on observers on the ground relying information to pilots in the air. This has become widely known as 'CABRANK', the orbiting of

aircraft until such time that they are vectored onto a target. While CABRANK, with its emphasis on loitering over the battlefield, was not in fact widespread, it was utilized on the battlefield:

aircraft would proceed to a rendezvous at about 5,000 ft. and then report by R/T to the Contact Car. The Contact Car would then pass to them the tasks and give them the information about the target with the aid of special grids which were previously drawn on the maps or with the aid of landmarks. (Hills or valleys could not be taken as landmarks for the pilot.) After carrying out the attack the pilot would return to the rendezvous point. The co-operation between the aircraft and Contact Car would go on until all ammunition was spent or the defined time elapsed. Other sections, if required, would then take the place of the one which had just finished its task.⁵²

The need for precision and clarity between pilot and ground controller was obvious, yet as this and the following chapter on operations will demonstrate, the system remained seriously flawed.

On June 9, the tactical air forces were still based in England, resulting in a less than flexible system of air support, complicated by the atrocious weather. Three main conferences were held each day to review the air situation:

1. The Chief of Staff's morning conference at 0915 hours attended by all heads of Branches. The daily presentation included a summary of the air programme for the day and the previous day's air results given by the BGS (Ops).
2. The morning air conference followed under the chairmanship of the Chief of Staff. Senior staff officers of the Army Group and Second Tactical Air Force were present. A full description of the military situation was given, and questions of policy and broad future planning were discussed.
3. The evening conferences at Second Tactical Air Force was held at 1730 hours under the chairmanship of the Air Commodore (Operations). The days operations on the ground and in the air were described by representatives from G(Ops)A and Air Staff (Operations) respectively. The main object of this conference was to agree on the detailed arrangements within the terms of the current policy for the next day's operations.⁵³

Air Marshal Coningham set the time for the evening conference at 1730 hours, forcing the army to determine its requirements for the next day more than twelve hours in advance. Efforts were made to persuade 2 TAF to change the hour but without success.⁵⁴ The air force required the time to incorporate army requests into its own plans; since it did not consider direct and close support to be high priority, there was no need to compromise.

If the system remained rigid at the top, it was more responsive in the battlefield area. The planners had developed a number of methods to limit the dangers of mis-identification of ground targets. The most important was the bomb line which would change whenever the situation warranted. As the name suggests a line was delineated on the field of battle that determined on which side an aircraft could attack targets. Sometimes this line might be defined as a major road. But, for attacks close to allied troops, a more precise method was required. Generally natural landmarks would be used but this was not always sufficient. The number and type of indicators employed varied widely and depended on the materials available and ingenuity of the troops involved. Bomblines indicators included:

- Large groundstrip sign
- Trench made with bulldozer
- Grader run over cultivated field
- Sign made with barrels or even parked vehicles
- White painted strip on tarmac road
- Tarred strip on a non-metalled road
- Coloured smoke or flares used to draw the attention to one of these landmarks⁵⁵

As can be seen, these methods are suited to a static front line. When the campaign evolved into one of rapid movement, these methods were no longer suitable and others were needed. An attempt to overcome this problem was the rule of thumb that arose during the campaign called the '2-hour' method. The rate of advance of the assaulting forces was estimated in distance on the ground and the area where the front line would be 2 hours from its previous position was designated as the bomb line.⁵⁶ The predictions of allied advances were sometimes overly optimistic, which resulted in placing the German forward defensive line on the same side of the bomblines as allied ground forces. Combined with the mass movement of troops and vehicles and the difficult nature of the terrain, incidents of friendly fire were to occur frequently.

It would be helpful at this point to examine the procedure whereby pilots were briefed before commencing a sortie. In a move to standardize such briefings and keep them as straightforward and quick as possible, HQ 2 TAF circulated a memo in May 1944 detailing the components of a briefing. Each would begin with the Intelligence Officer discussing the target, location of flak, useful landmarks such as rivers and railway tracks that would assist in locating the target, and the possibility of encountering enemy fighters in the area. To assist in his briefing the I.O. had at his disposal several visual aids:

Briefing Board - this was a large map at 1/100,000 scale covering the target area. Over top of it was a clear sheet on which flak positions and the approach to the target were marked.

Pilot's Briefing Board - most often this was a black chalk board. On it were details indicating the course to be followed, timing, radio frequencies to be used, speed and call signs. For rocket Typhoons additional information was included noting the angle of dive and sight setting for the gun sight.

Pilot's Information Board - this consisted of actual photographs of the target along with a map at 1/50,000 detailing flak positions in the area and indicators for the bomblines.

Course Board - consisting of a 1/500,000 scale map this board illustrated the entire mission route both to the target and back.

Course Cards - these were carried by the pilots, who copied on them such information as the route to be flown, call signs, distances and timings.

Meteorological Board - the latest weather updates were constantly posted on this.

If the mission was to be directly supporting ground forces, an army Air Liaison Officer would be present as well to brief pilots on the ground situation, particularly the landmarks related to the bomb line. Next the Wing Leader would address the pilots, laying out the flying tactics to be used. It was the duty of the Wing Leader or his deputy to oversee the planning of the operation and the briefing of the aircrews. Should different squadrons within the wing be given different missions then the respective Squadron Leaders would also give a briefing.⁵⁷

Particular attention was paid to the location of flak batteries, as flak against fighters had long been recognized as the most dangerous weapon the Germans possessed against fighters in ground attack roles. A June 15 report gave estimates of the likelihood of being shot down based on what calibre flak was used. A hit from a 40mm or larger cannon shell was lethal 90% of the time, whereas it took 4 hits from 20mm cannon to have the same effect. However, as a 20mm fired four rounds per second versus one round per second by 40mm, the lethality was deemed virtually the same. The report also reaffirmed the obvious truth that low level attack was the most

dangerous mission.⁵⁸ This was no surprise to the RAF, who had over 2 years of experience of flak and single engine fighters.

A week after D-Day, the Anglo-Canadian forces were on the defensive but, in the words of General Montgomery, “aggressively so”. The city of Caen, originally planned to fall on D-Day, remained in German hands. The massing German armoured formations brought up to keep the British and Canadian forces from expanding into and beyond the city presaged the difficulties that would follow in advancing beyond Caen. As the German defences solidified in front of them the allies were faced with the problem they knew was inevitable; attacking against well-prepared defences with weapons inferior to those used by the Germans. Three weapons in the allied arsenal were employed to compensate for this; the German ability to defend against them was mixed. Massive amounts of naval gun fire could be fired inland; such fire was devastating on German counter-attacks when their forces were out in the open. Neither the German Navy or Air Force could effectively impede these guns as long as the Allies maintained air superiority. The downside to naval support was that once the fighting moved farther inland the front line would eventually be out of reach of these guns.

The combined allied heavy bomber force was also employed on the battlefield and, again, was virtually free of German harassment. However, the use of heavy bombers in close support of ground forces was risky and their ultimate value remains questionable.

The one remaining weapon that was available to alter the balance on the battlefield on a large scale was the tactical air forces. They were capable of attacking singly or in large formations; they were fast, capable of carrying sizable payloads and, theoretically at least, able to defend themselves without fighter escort. The reality was somewhat different, as we shall see. For 83 Group, assigned the role of providing support to the British 2nd Army, the hoped for space to construct airfields in the vicinity to the South of Caen remained unrealized and so the bulk of the squadrons were forced to continue flying from their bases in England.

As the initial chaos and exhilaration of D-Day subsided, the allies began to focus on the problems at hand, the capture of Caen and Cherbourg. The expected and desired support of the tactical air forces was muted by the almost constant bad weather in England and Normandy, limiting the number of sorties the fighter-bombers could fly in support of the army. During the period June 9 through 21, 83 Group squadrons claimed only 3 tanks, 94 MET and 35 aircraft destroyed. For a unit comprising over 400 fighters and fighter bombers these totals illustrate just how difficult weather, terrain, camouflage and enemy opposition could be. In this same period of relative ineffectiveness, 83 Group lost 39 aircraft and 24 pilots.⁵⁹

An unexpected gale beginning on 19 June halted almost all supply to the invasion forces as ships and artificial harbours were pounded by wind and waves. When the storm finally lifted on the 22nd, it left in its wake destruction on a scale the Luftwaffe and Kriegsmarine could only dream of. Hundreds of landing craft and ships were damaged, destroyed or beached. The Mulberry harbour in the American sector was

destroyed.⁶⁰ With supply dumps having been only recently established in the beachhead, the situation had the potential to become critical. The tactical air forces stepped up their activities to assist the armies.

The last week of June saw an upswing in 83 Group claims, not the least of which was daily encounters with the Luftwaffe. From 23 to 30 June, 83 Group claimed 84 enemy aircraft shot down with a loss of 37. Operation EPSOM, originally scheduled for June 22 but postponed due to the gale, was designed to take the high flat ground to the south and south east of Caen which, among other things, would provide 2 TAF with its much desired space for airfields. Flying in support of EPSOM on 25 June, 83 Group put up 114 aircraft on armed reconnaissance, 97 on dive bombing, 21 on tactical reconnaissance and 194 on defensive patrols and escorts.⁶¹ As the number of enemy aircraft claimed in this period suggests, the Luftwaffe was by no means absent from the battlefield. It is also instructive to note that almost half of the missions flown that day were protective in nature.

The support that 83 Group could provide to British 2nd army, both direct and indirect, grew in importance as the attritional fighting in Normandy depleted the front line combat units. The need was simple: use the advantage of a large mobile air force to assist the infantry in its advance against well prepared defences strengthened by a large assortment of deadly support weapons such as the Nebelwerfer (Moaning Minnie) and 88mm gun. Technological advances had heralded astounding changes in weapons since the last war which, for the infantry, made their task all the more difficult:

As in the previous war the infantry was expected to lead the attack on the enemy. [-] this normally meant advancing in extended line, behind an artillery barrage across open rising country which the enemy had carefully surveyed to ensure that his artillery and mortars were registered on every patch of ground. During the Battle of Normandy the infantry was expected to conform to rigid, timed artillery fire plans and urged by their commanders to “lean” into the barrage. If something went wrong, and it frequently did, the barrage would be ‘lost’ and further advance would depend on the courage of individuals. Once established on their objective, their real troubles began as German counterattacks were quickly launched often before consolidation could be achieved.⁶²

It is hardly surprising then that the infantry suffered the highest number of casualties in the campaign. By the 30th of June the allies had suffered 61,732 killed, wounded and missing in battle, the bulk of these being in front line rifle companies.⁶³

By the first week of July British Second Army was sufficiently re-supplied and reinforced to renew large scale operations. Heavy fighting along the Anglo-Canadian sector front occurred during the period July 4 through 7 as the Canadians attempted to take Carpiquet airfield near Caen, as a precursor to the capture of the city outright. On the evening of July 7, Operation CHARNWOOD began with the intent of capturing Caen. That night the first use of heavy bombers in a close support role was authorized to blast a path through the German defensive ring around the city. The next morning 83 Group began intensive operations in support of the attack which continued, although hampered by bad weather, on the 9th. By that evening all of Caen on the north-west side of the Orne river had been taken, forcing the Germans to retreat to the south and east. Montgomery’s next move was to consolidate this gain in preparation for the next offensive that would take the rest of Caen and push out into the flat plains beyond.

By July 11 the bridgehead had still not expanded much beyond the original landings. The Cotentin peninsula was now in allied hands, as was the port of Cherbourg, and Caen had finally been entered by Canadian and British forces, but the bridgehead still did not exceed 20 miles in depth, and was only 10 miles deep in some places.⁶⁴ The effect of this narrow lodgment was to seriously congest traffic and supplies. For 83 Group, which was tasked with supporting British 2nd Army, the problem was immense. The number of airfields constructed was curtailed both due to the limited area in which to build them, and the fact that those built were within range of German artillery. As of D+35, the number of squadrons based in Normandy was “less than half the number” planned.⁶⁵ Lack of progress by Montgomery in securing the large flat plains beyond Caen for more airfields was not the only reason, however, for keeping the Typhoons based in England during the first part of the campaign.

Labeled the ‘Dust Menace’, the fine chalk powder of Normandy was to prove more effective in curtailing Typhoon operations from the continent than the Luftwaffe or long range artillery. A June 23rd report by 2 TAF revealed a serious problem: “Typhoon Aircraft have been withdrawn from the Continent owing to the dust menace.”⁶⁶ For an air force tasked with support of ground forces this was a serious but not critical setback that for a brief period hampered their ability to provide close support. It also points out the problems that can follow when using aircraft not specifically designed for their role. Luckily, the solution was a relatively simple and quick repair; combined with the spraying of airfields with water and oil to keep the

dust down, as well as guide lines on the removal of the top surface by graders, the Typhoons were soon back on the continent to stay.⁶⁷

In support of Operation GOODWOOD, 83 Group, reinforced by squadrons of 84 Group conducted intense armed reconnaissance missions behind the front line of the intended offensive on 17 July. Their area was a rough quadrilateral approximately 60 miles deep and 100 miles wide with the river Seine as its eastern boundary, bordered by Beny Bocage - Domfront - Alencon - Dreux - Mantes Gassicourt - Quillebuef.⁶⁸ Intelligence records for that day indicate 83 Group alone dropped 165 bombs and fired 462 rockets; claimed 1 tank damaged, 28 trucks destroyed and another 43 damaged, as well as 13 enemy aircraft shot down.⁶⁹ Not one of the enemy aircraft destroyed was claimed by a Typhoon pilot, giving a fairly clear indication of where their attention lay. The next day the offensive began. 83 Group support rose dramatically as 631 bombs were dropped and 2,295 rockets fired in the same area. Claims also rose as no less than 11 tanks were thought to have been destroyed from the air. Air-to-air claims fell to just 2 enemy aircraft destroyed but losses to 83 Group aircraft sky rocketed from just 3 on the 17th to 10 on the 18th illustrating the deadly nature of German flak for ground attack missions.⁷⁰

Operation GOODWOOD also heralded the first experiment in the Visual Control Post (VCP), comprising a Forward Air Controller and Air Liaison Officer in a Sherman tank. At four times during the day, six Typhoons formed a 'CABRANK' to be directed by the VCP, but each time no targets were transmitted to the waiting aircraft.⁷¹ The Forward Air Controller (FAC) was wounded almost immediately,

limiting the ability of the VCP to perform its functions. In any event the VCP proved difficult to implement for a good view of the target meant the enemy could most likely see the VCP equally well.⁷² By 1030 hours only 2 calls for air support had been logged but from then until 1900 hours the rate increased, resulting in 162 aircraft responding to attack a variety of targets, the most numerous being German tanks.

The next day, Typhoons responded with 50 sorties on Army support, but again they were unable to establish contact with the VCP. GOODWOOD was slowly grinding to a halt and the efforts of the fighter bombers of 83 Group could do little to get it going again. Bad weather then moved in and 83 Group was unable to fly any sorties on July 21 and only 24 the following day. On the 23rd of July, 83 Group managed 133 sorties, and as the weather improved flew almost 500 on the 24th in preparation for the next offensive, Operation SPRING. The hope, expressed by Montgomery, was that victory would be achieved in the Eastern sector, the Anglo-Canadian sector, by a continuation of the objectives of GOODWOOD commencing on the 25th.⁷³ A breakthrough did result from the two offensives launched on the 25th, but it was Operation COBRA, the American offensive, that achieved the breakout and heralded the shift from static to mobile warfare in the campaign.

A report that compared Typhoon rocket and bomb attacks issued on July 25 apparently received little attention at the time. The report was based on 811 Typhoon sorties and made some startling conclusions. First among these was that Typhoons equipped with bombs were superior to rocket-equipped Typhoons when attacking soft targets.⁷⁴ In 83 Group only 3 of the Typhoon squadrons flew 'Bombphoons'

compared with 8 that were rocket-equipped. This was yet one more indication that the rocket's performance as a battlefield weapon was less than had been hoped, although perhaps as had been expected.

Another discovery of note was the high loss rate among Typhoons, 35 being lost while rocketing and another 27 while bombing, all in the space of three weeks. Correlated with this was the increased likelihood of a pilot not returning from a mission the deeper he flew into enemy territory. Both sets of data made perfect sense considering the danger associated with flying low in a high flak environment in an aircraft not well protected from ground fire. The deeper one flew behind the lines also increased one's chance of encountering the Luftwaffe, getting lost, or merely succumbing to what would have been a non-terminal hit to the aircraft closer to the airfield but was terminal further away. Distance equals time, and for the short range Typhoon the longer it remained in the danger zone, the less likely it was to come back.

Analysis by Depth of Penetration & Flak areas, Comparing 83 & 84 Group

Typhoon Casualties Against All Targets⁷⁵

	0-10 miles from front line			10-20 miles from front line			20-30 miles from front line		
	M	C	M per C	M	C	M per C	M	C	M per C
83 Grp RP	93	4	23.3	25	3	8.3	13	6	2.2
84 Grp RP	17	6	2.8	16	3	5.3	6	3	2.0
83 Grp Bomb	34	3	11.3	13	6	2.2	10	1	10.0
84 Grp Bomb	35	7	5.0	15	5	3.0	13	3	4.3

(Table 3.3) M = Missions C = Casualties

Typhoon Casualties due to Flak⁷⁶

	Area where flak expected			Area where flak not expected		
	S	C	S per C	S	C	S per C
83 Grp RP	950	10	95	525	5	105
84 Grp RP	506	6	84	216	4	54
83 Grp Bomb	292	8	37	253	7	36
84 Grp Bomb	483	13	34	212	4	53

(Table 3.4) S = Sorties C = Casualties

Using the commencement of Operations SPRING and COBRA as a useful division in the conduct of the Normandy campaign, one can see how the operations of the tactical air forces in the first half were primarily concerned with the maintenance of air superiority and protection of bomber and fighter-bombers and the ground and naval forces below. For the months of June and July 1944, 2 TAF flew fully 50% fighter sorties concerned with air-to-air combat compared to 40% ground attack sorties.⁷⁷ Of these ground attack missions, just over half were of the type considered close support involving the firing of rockets and dropping of bombs on targets very near or at the front line while the other half were armed reconnaissance/interdiction far away from the front line. Roughly, 80% of all tactical air support provided by 83 Group and 2TAF in this static phase was not in the vicinity of the front line.

From the very beginning the RAF had argued that this was the proper way to conduct air support operations, citing the greater importance of interdiction while downplaying the value and acknowledging the immense problems of attacking pinpoint targets on the battlefield. RAF adherence to this doctrine was certainly a reflection of its desire to maintain independence, but more fundamentally the doctrine reflected the operational realities of the campaign and the limitations of the aircraft and the pilots

that flew them. Foremost among these was the almost absolute vulnerability of 83 Group aircraft to flak. Using the available data one must consider that if, in flying just 40% of all sorties as ground attack resulted in 83 Group losses of over 200 aircraft in a two month period. How great would the losses for that same period become had the ground attack role been increased? At the same time an increase in ground attack would have meant a decrease in the protective cover above the allied forces at a time of great vulnerability to an enemy air force that, while weakened, was by no means eliminated.

At the beginning of a mobile phase of warfare in Normandy, the number of missions devoted to ground attack would in fact increase dramatically, as the enemy fled the field of battle and presented the most opportune target the allied tactical air forces would have during the entire war.

Operation COBRA signaled the beginning of the end of the Normandy campaign, although it would take another month of extremely hard fighting to reach it. The phenomenally high attrition rate during the static phase, most marked in the front line infantry units, was serious on the allied side but catastrophic for the German defenders. One of the most crucial elements to this imbalance was the virtually unhindered supply and reinforcement of the allied armies in Normandy, while the German army suffered almost constant air attack while attempting the same.

Now the application of tactical air support in Normandy will be examined in the context of a more mobile and therefore chaotic battlefield. The RAF had long argued that this was the very situation where air power could prove of most value, when

employed in directly attacking enemy ground forces, by turning a retreat into a rout. Such a shift from maintenance of air superiority and interdiction to ground attack brought with it inherent dangers not only to the aircraft and pilots who would fly them, but to the very forces they were supporting.

The last week of July proved to be the busiest and deadliest for 83 Group thus far in the campaign. July 25 witnessed the dropping of over 550 bombs and the firing of 2,599 rockets, although the claims of 3 tanks and 39 MET destroyed hardly compensated for the ordnance expended or the loss of 17 aircraft and 14 pilots.⁷⁸ As Operation COBRA continued it became clear that the breakout from the bridgehead had finally taken place in the US sector. Almost two months of static warfare were now replaced by rapid movement that would culminate near the small French town of Falaise.

The flexibility of centrally controlled tactical air was clearly demonstrated when 83 Group flew missions in support of COBRA in the American sector, attacking strong points and armoured formations in harbour. They claimed 16 tanks destroyed, another 25 damaged and almost 100 MET destroyed or damaged.⁷⁹ The increase in claims was a reflection of the fluidity of the battlefield which presented the fighter-bombers with ever growing numbers of targets in the open as German units moved either toward or away from the rapidly changing front line.

As the campaign progressed it became apparent that little hard evidence was being gathered on fighter-bomber attacks. A memo to the Scientific Advisor 21 AG from ORS/2TAF dated 21 June pointed out the real problem of not knowing how effective

air attacks were, “the only specific information on the effectiveness of the attack is what comes through the eyes of the pilot, with the, fortunately rare, exception that when the attack goes badly wrong signals come from the ground forces.”⁸⁰ It was this lack of corroborating evidence from ground examination of ‘destroyed’ targets that gave impetus to the combined Army/2TAF OR sections to examine the battlefield as “conversations between S.A. and the Operational Research Section at 2nd TAF have led to the idea that there is a requirement for more complete and accurate reporting by the Army of the results of direct air support.”⁸¹

A search of the area around La Baleine where 121 Wing of 83 Group flew 99 sorties against a column of retreating German vehicles with rocket firing Typhoons produced the following information: (Table 3.5)

Summary of Vehicles Found and Investigated at La Baleine⁸²

	Destroyed by:						Abandoned	Totals
	R.P.	Possibly R.P.	unknown shells	unknown causes	crew			
Panther	1	-	1	-	3	3	8	17
PzKw MkIV Special Armoured Cars	1	-	-	-	-	-	1	
Armoured Troop Carriers	5	1	-	-	-	-	1	
75 mm S.P.	-	-	-	1	-	1	2	
50mm Anti-tank guns	-	-	-	-	1	1	2	
Howitzers	-	1	-	-	-	1	2	5
Pupschens	-	-	-	-	-	1	1	
Lorries	-	-	-	8	-	-	8	18
Cars	-	-	-	10	-	-	10	
Totals	7	2	1	19	4	7	40	
33 Destroyed								

(Table 3.5)

Only a fraction of the destroyed enemy vehicles found could be directly attributed to the rocket projectile. Combining the confirmed and possible categories of destruction by RP the report suggested the destruction of 9 enemy vehicles, only two of which were tanks. As 99 sorties were flown and each Typhoon normally carried 8 rockets, this meant close to 800 rockets had been fired at this column, roughly 88 rockets and 11 sorties per destroyed vehicle.⁸³ For the RAF such findings only confirmed what training and previous operational data had suggested, the fighter-bomber required favourable conditions and a surprisingly large number of sorties per target to be effective in a ground support role.

As July turned to August, the weather, previously uncooperative for the allies, began to bear a truer reflection of a sunny Norman summer though this included an almost constant ground mist that shrouded the land until mid morning.⁸⁴ On the 7th of August the Germans launched their first and only major armoured counter-attack of the Normandy campaign near the village of Mortain in the American sector of the front. A hurried series of phone calls saw the squadrons of 83 Group immediately diverted to assist the Americans in stopping the attack. By 1300 hours the first squadrons of 83 Group were in the area and almost at once spotted large formations of enemy armour and transport moving on the roads. They attacked and for the rest of the day until nightfall 83 Group expended over 400 500lb bombs and 1,885 rockets as they repeatedly attacked the German formations. In a day never to be equaled, 83 Group pilots claimed a staggering 82 enemy tanks destroyed and 47 damaged with 88 MET destroyed and 128 damaged, for the loss of 9 aircraft.⁸⁵ The following day only

5 additional tanks were claimed destroyed giving a clear indication that the offensive had been halted. Now known as the 'Day of the Typhoon' the destruction wrought by the fighter bombers of 83 Group was offered as proof positive that Typhoons could be used successfully in ground support roles and that it was their intervention that was decisive in stopping the German advance. Part of the success was no doubt due to the fact that the closest the Luftwaffe got to the battlefield that day appears to have been around Couterne, to the east of Mortain as IXth Air Force fighters intercepted German aircraft sent to provide air cover for their own formations.⁸⁶

The report filed by Coningham after the counter-attack noted that at Mortain the ideal conditions were presented for tactical air power to affect a land battle. These were listed as large, closely gathered formations of armour and transport in a limited space, almost no flak or enemy fighter opposition, and the ability to use air power at the height of the battle unhindered by weather or other factors.⁸⁷ Such optimal conditions rarely presented themselves, and so Mortain stands as a perfect example of what air power could do.

The ORS report (Table 3.6) however, questioned the numbers claimed by the fighter bombers.

Results of Ground Investigation at Mortain⁸⁸

Results of Ground Investigation										
Type of Vehicle	Destroyed by			Air Total	Abandoned Intact	Destroyed by crew	Destroyed by US Army	Unknown Causes	Total Found	
	RP	Cannon or M.G.	Bomb							
Armour	Panther	5	-	1	6	6	4	14	3	23
	Mark IV	2	-	1	3	1	-	5	1	10
	SP Gun	-	-	-	-	-	-	1	2	3
	Arm'd Troop Carrier	7	4	-	11	1	-	3	8	23
	Arm'd Car	1	-	-	1	1	-	5	1	8
	Arm'd Recovery Vehicle	-	-	-	-	-	-	1	-	1
	Total	15	4	2	21	9	4	29	15	78
MT	Car	2	2	-	4	-	-	4	3	11
	Lorry	-	6	-	6	1	1	2	20	30
	Ambulance	-	2	-	2	2	-	-	1	5
	Motorcycle	-	-	-	-	1	-	1	2	4
	Total	2	10	-	12	4	1	7	26	60
Grand Total (Armour & MT)		17	14	2	33	13	5	36	41	128

(Table 3.6)

From 12 to 20 August two ORS teams, one from 21 Army Group and the other from 2 TAF, combed the area documenting as many vehicles as possible. What they found echoed their earlier investigation at La Baleine: pilot claims were highly exaggerated. Only 7 tanks were believed to have been destroyed from the air, compared with 14 by the US army. In fact there were just 43 damaged tanks discovered in the area, and of these only 9 could be definitively attributed to air attack.⁸⁹ The great discrepancy between pilot claims and the evidence on the ground prompted the 2 TAF team to argue that the efficiency of the German tank recovery system accounted for many of the missing tanks. This hypothesis was rejected, however, as it seemed highly unlikely that the Germans would recover burnt-out tanks while leaving undamaged ones

behind. Further, the army ORS team established that in fact very little recovery took place at Mortain, as at this point in the campaign “the repair and recovery teams were already pulling out of Normandy.”⁹⁰

The day after the Mortain attack began the fighter bombers of 83 Group were switched back to assist in Operation TOTALIZE. They attacked several pre-arranged targets identified as anti-tank guns, dug in infantry, mortar and artillery positions. No ground survey was undertaken so it proved impossible to verify claims of success.

On 10 August the bomblines were arranged to give 2 TAF an area north of Vire-Argentan-Dreux-Mantes-Gassicourt-Arras-Boulogne, which positioned 83 Group to attack German formations as they retreated across the Seine river and beyond.

August 17 marked the first day of what would be a three day slaughter of German armour and other transport in and around the Falaise Pocket, with 83 Group alone flying over 2,800 sorties. Not since the German counter-attack at Mortain had so many targets been visible on roadways and in fields. That day 18 tanks and 248 MET were claimed as destroyed, for the loss of 7 aircraft and 6 pilots.⁹¹

By 18 August the Gap was less than 10 miles across. It was on this day that 83 Group had its busiest 24 hours of the whole campaign. Flying over 1,300 sorties the fighter-bombers made their second biggest claim of destroyed German tanks, 73, and largest claim for MET, a staggering 1,074 destroyed and another 1,712 damaged. Such intensive low level flying came with a price as 83 Group also recorded its worst losses of the campaign, 25 aircraft downed and 19 pilots lost.⁹² 18 of the downed

aircraft were Typhoons, showing the disparity of loss rates between that fighter-bomber and others in 83 Group.⁹³

August 19 was not quite as hectic but still presented a full day's work. Another 12 planes and 11 pilots were lost for a claim of 37 tanks destroyed and 479 MET destroyed.⁹⁴ By the 20th the bomblines had been moved north and only 2 tanks and 67 MET were claimed as destroyed. Over the three day period of 17 through 19 August, 83 Group lost 44 aircraft and 36 pilots while claiming 128 tanks and 1801 MET destroyed.⁹⁵ Viewed in this way the success versus the cost of the fighter-bombers becomes debatable. Clearly such high intensity operations were rare. It is also clear that 83 Group could not sustain such losses for an extended period of time.

By the 21st of August the gap had been closed and there was little armour left to attack and claims of only 2 destroyed tanks and 67 MET were recorded, although 11 enemy aircraft were shot down for the loss of 3 aircraft and 3 pilots. From this point to the end of the month, 83 Group would claim just another 11 tanks destroyed and 416 MET destroyed, while losing a further 17 aircraft and 10 pilots.⁹⁶

In the chaos surrounding the closing of the Falaise Pocket and the close proximity of allied and German forces in hilly, tree covered terrain, it is clear that at least some of the claims made by the pilots of 83 Group were in fact attacks on their own troops. During the period 14 August through 18 August, a Canadian armoured regiment, the South Albertas, was attacked on six different occasions by Spitfires and Typhoons of 2 TAF.⁹⁷ Casualties were not severe but there was no question that "everyone was much happier when the Typhoons winged away."⁹⁸ During one attack the CO of the

SARs became so incensed at the continued strafing runs by Spitfires in spite of recognition smoke and the clearly visible allied markings on the vehicles that he “ordered the two Crusader AA tanks - to open fire” [but] was dissuaded by Padre Wilcox, who risked his own life to warn off the fighters by laying out a Union Jack.”⁹⁹

The closing of the Falaise Pocket on August the 21st signaled the end of the Normandy campaign, although the fighting continued as what was left of the German 7th and 15th armies retreated across the Seine river. The carnage found in and around the pocket was incredible. Once again the Operational Research teams combed the area in an attempt “to ascertain the extent of the enemy’s losses due directly or indirectly to air attack and to assess the effectiveness of different air weapons.”¹⁰⁰ The area studied was divided into three portions, called the Pocket, the Shambles and the Chase. As the following table shows, it was the canon and machine gun and not the rocket and bomb that caused the most damage.

**Analysis of Damage by Air Attack to
Enemy Equipment During the Pocket Period¹⁰¹**

	Rockets	Bombs	Cannon/MG	Air Total	Abandoned/ Destroyed by crew	Totals
Tanks/SP guns/AFVs	11	4	18	33	100	133
Motor transport	4	43	278	325	376	701
Guns	-	-	1	1	50	51
Totals	15	47	297	359	526	885
Percentages	1.7	5.3	33.5	40.5	59.5	

(Table 3.7)

The following map illustrates the funnel effect as German forces were forced to retreat through an ever narrowing 'Gap', providing a wealth of targets for tactical aircraft.

Enemy Vehicles Found in 'The Pocket', August 1944¹⁰² (Fig. 3.3)

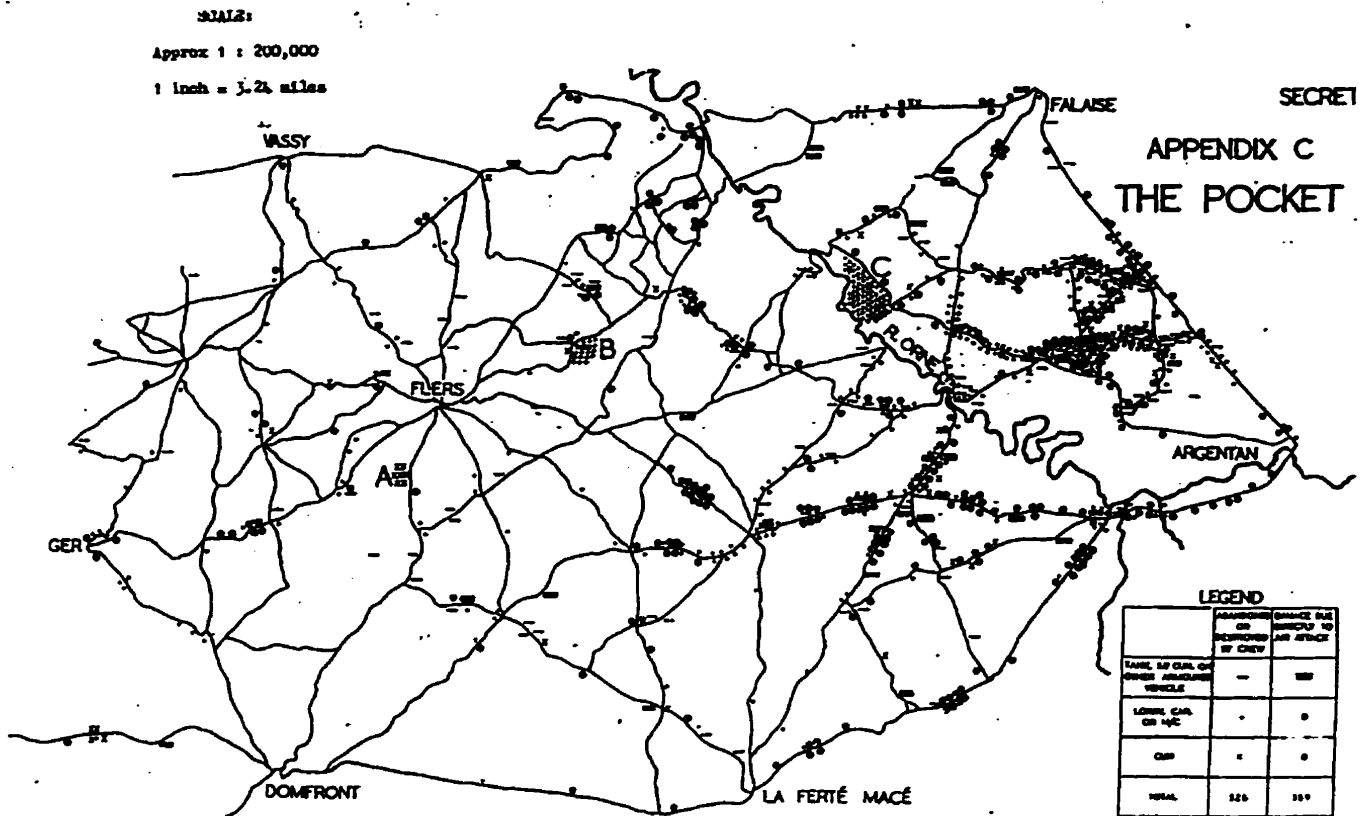

The second area searched, 'The Shambles' yielded far more vehicles than the Pocket itself. It was estimated that 3,043 vehicles, tanks, and guns were lost in this area which is categorized in the following table (Table 3.8):

Enemy Vehicles Found in the 'Shambles', August 1944¹⁰³

	TANKS AND S.P. GUNS	LIGHTLY ARMoured VEHICLES	LORRIES	CARS	GUNS
BURNT	112	64	1011	224	-
UNBURNT	75	93	767	445	-
TOTALS	187	157	1778	669	252

(Table 3.8)

Of these, "about eight hundred vehicles may reasonably be considered as directly destroyed by air attack and a somewhat larger number as abandoned along roads which were attacked by aircraft."¹⁰⁴ As with the Pocket, a map of the Shambles reveals the incredibly dense concentration of vehicles created by a retreat along a single and narrow route.

Map of Enemy Vehicles Found in the 'Shambles' August 1944¹⁰⁵ (Fig. 3.4)

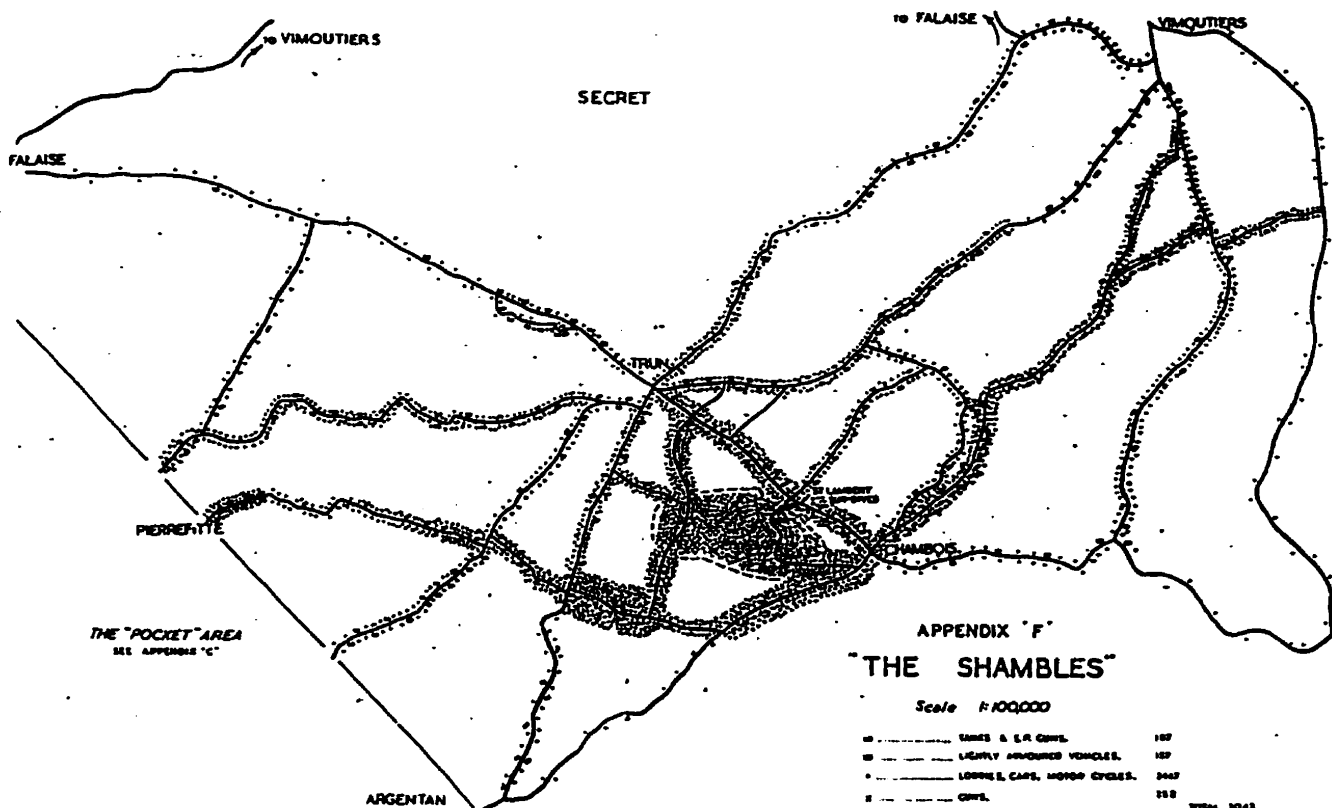

The third and final area to be examined was known as the 'Chase' and contained the largest number of vehicles of all three areas, 3,648.

Enemy Vehicles Found in the 'Chase' August 1944¹⁰⁶

	Tanks and SP Guns	Lightly Armoured Vehicles	Lorries, Cars and M/Cs	Guns
Burnt:	114	115	2275	-
Unburnt:	36	39	903	-
Totals:	150	154	3178	166

(Table 3.9)

Grand Total: 3648

Map of Enemy Vehicles Found in the 'Chase' August 1944¹⁰⁷ (Fig. 3.5)

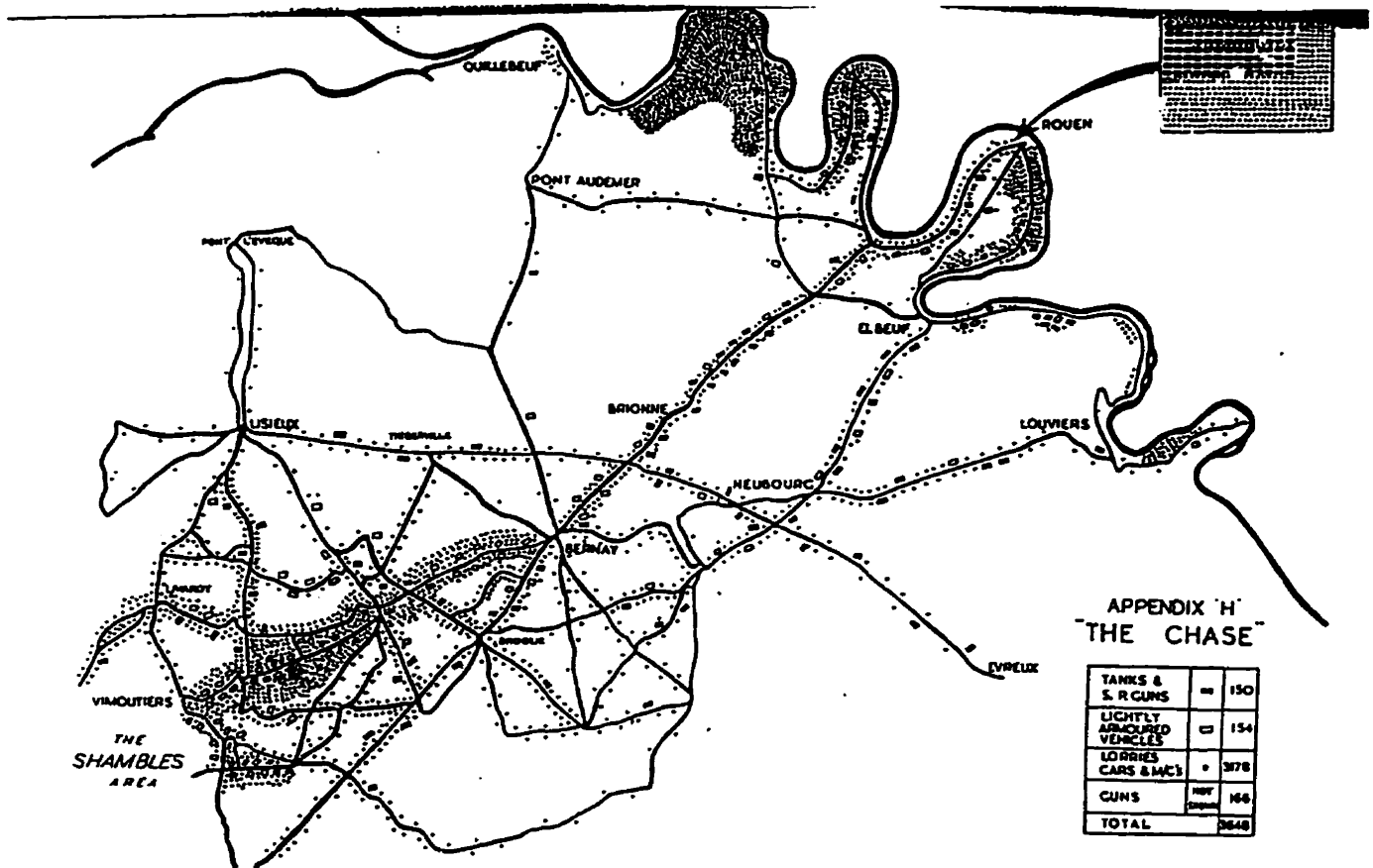

The sheer numbers of vehicles precluded yet another in depth search, but the armoured vehicles were given more attention. Of the 150 tanks observed not one could be definitively classified as having been destroyed from the air.¹⁰⁸ Even so, it is likely that at least some portion of the vehicles were abandoned due to fuel shortages, the demoralization of the crew or blockage of the road by trucks and horse drawn wagons that had been destroyed by air attack. However, no data was gathered to verify this, and the subject remains one for speculation. What is clear is that the fighter-bomber, equipped with either rockets or bombs, did not directly destroy German armour in the closing act of the Normandy campaign. The fighter however, equipped with machine guns and canons wrought havoc among the retreating German forces and amassed the lion's share of the victories.

For the final battle of the Normandy campaign, the pilots of 83 Group claimed to have destroyed 141 German tanks and 2,284 MET.¹⁰⁹ While it seems clear that these claims, at least for the armoured vehicles, are wildly optimistic, the fact remains that the battle of the Falaise Pocket was a defeat every bit as great as that handed to the Germans at Stalingrad. In the fifth year of the war, two German armies had been defeated and routed from the field of battle in less than three months. The Normandy campaign was a huge success for the western allies, and tactical air power had played part in the victory.

End Notes to Chapter 3

¹ J.L. Granatstein and Desmond Morton. Bloody Victory: Canadians and the D-Day Campaign, 1944, p 10.

² The Liberation of North West Europe Vol III Chapter 3, p14(a). AIR 41/24 169523

³ Ibid. p 177.

⁴ Ibid. Chapter 6, p 56.

⁵ Ibid. p 58.

⁶ Ibid.

⁷ Ibid. p 61.

⁸ Air Chief Marshal Leigh-Mallory. 'Operations by the Allied Expeditionary Air Force in NW Europe' in the *London Gazette*, January 1947, section 325.

⁹ Ibid. AIR 41/24 169523 p 142.

¹⁰ Ibid.

¹¹ Ken Delve. D-Day: The Air Battle, p 62.

¹² Richard Townshend Bickers. Air War Normandy. p 43.

¹³ Report on Air Operations Prior to and in Support of Neptune Allied Expeditionary Air Force, Air Historical Branch. AIR 37/757 170816 p 51.

¹⁴ AIR 41/24 169523 Chapter 11, p 145.

¹⁵ Ibid.

¹⁶ Ibid. p 146.

¹⁷ Ibid. p 150.

¹⁸ Ibid. p 151.

¹⁹ Ibid.

²⁰ Ibid. p 153.

²¹ Ibid. p 154.

²² Ibid. p 155.

²³ This definition is listed in Case Studies in the Achievement of Air Superiority, edited by Benjamin Cooling, taken from the United States Department of Defense Dictionary of Military and Associated Terms, p xv.

²⁴ Lord Arthur Tedder. Air Power in War, p 35.

²⁵ Ibid. p 41.

²⁶ AIR 41/24 169523 p 139.

²⁷ F.H. Hinsley. (Official History) British Intelligence in the Second World War: Its influence on Strategy and Operations. Volume III, Part 2, 1988. Appendix 12 from JIC (44) 215 (O) of 25 May, p 827.

²⁸ Ibid. p 828.

²⁹ AIR 41/24 169523 p 47.

³⁰ Hinsley. Appendix 12.

³¹ Hinsley p 44 and Lewin, Ultra Goes to War p 397.

³² Ellis, Victory in the West, p 295.

³³ Diary of Able Seaman W. Cutler aboard HMS Largs off of Sword beach, June 7, 1944. IMW 89/3/1

³⁴ H. Meyer. Kriegsgeschichte der 12 SS Panzerdivision "Hitlerjugend" Osnabrueck, 1987, p 52.

³⁵ Bickers. Air War Normandy, p 77.

³⁶ AIR 41/24 169523 p 148.

³⁷ DND DHist 94/142 'Army/Air Operations Pamphlet No. 2' p 18.

³⁸ Ibid. p 17.

-
- ³⁹ AORG Memo A8 Appendix D. WO 291 1178 121054
- ⁴⁰ DND DHist 94/142 p 19.
- ⁴¹ Ibid. p 8.
- ⁴² ORS 2nd TAF Report No. 30 (July 1945), Armed Reconnaissance by Aircraft of 2nd TAF in the Western European Campaign. WO 291/1357
- ⁴³ Tactics used by Squadrons of the 2nd TAF during the Campaign in Western Europe, Part III, May 1951. Air Historical Branch, p 2. AIR 37/835 168909
- ⁴⁴ Ibid. p 2.
- ⁴⁵ The Effect of Air Attack. Air Ministry Intelligence Report No. 382/1944, 24 July, 1944, p 6. AIR 37/760 170816
- ⁴⁶ Robert Vogel. 'Tactical Air Power in Normandy: Some Thoughts on the Interdiction Plan' in *Canadian Military History*, Volume 3, Number 1, Spring 1994, p 40.
- ⁴⁷ Ibid. p 45.
- ⁴⁸ Ibid. p 44.
- ⁴⁹ Ibid.
- ⁵⁰ 83 Group Intelligence Summary for June, 1944 IMW 83/15/3
- ⁵¹ Army Air Training Instruction No. 1 1943 Army Air Operations p 6. AIR 8/988 92396
- ⁵² Tactics used by Spitfire Day Fighter/Bomber Squadrons of the 2nd Tactical Air Force During the Campaign in Western Europe. Tactical Paper No. 4, Air Historical Branch, 1947, p 8. AIR 20/6857 92550
- ⁵³ WO233/61 xc7225 Air Support and Air Reconnaissance Aspects of Combined Operations in NW Europe, June 1944 - May 1945, Chapter 2, p 4. WO 233/61 xc7225
- ⁵⁴ Ibid.
- ⁵⁵ Army/Air Operations Pamphlet No. 2 Direct Support 1944. The War Office, April 1944. DND Directorate of History 94/142, p 37.

-
- ⁵⁶ W.A. Jacobs. 'The Battle for France 1944', p 267.
- ⁵⁷ Standardized Briefing for Fighter and Fighter-Bomber Aircrews. HQ 2 TAF Air Staff Instruction, 15 May, 1944. AIR 37/651 168896
- ⁵⁸ AORG Memorandum No. 340 Effect of Enemy L.A.A. on British Fighter Bombers 15 June 1944. WO 291/671
- ⁵⁹ Papers of Squadron Leader RT Wilkins. 83 Group Intelligence Summaries. IMW 83/15/3
- ⁶⁰ Ellis. Victory in the West p 274.
- ⁶¹ AIR 41/67 Vol IV p 14.
- ⁶² Terry Copp and Robert Vogel. Maple Leaf Route: Falaise. p 32.
- ⁶³ Ellis, Victory in the West, p 307.
- ⁶⁴ Copp and Vogel. Maple Leaf Route: Falaise. p 6.
- ⁶⁵ Ibid. p 8.
- ⁶⁶ Air37/79 xc170903 Visit of A.O.A. 2nd TAF to 83 Group Overseas - 23 June 1944, 24 June 1944 p 2. AIR 37/79 xc170903
- ⁶⁷ Ibid. p 2.
- ⁶⁸ AIR 41/67 Vol IV p 42.
- ⁶⁹ July 1944 Monthly intelligence assessment 83 Group from IWM papers
- ⁷⁰ Ibid.
- ⁷¹ AIR 41/67 Vol IV p 49.
- ⁷² The first VCPs were Sherman tanks still equipped with their main guns. This meant the aerial for the extra radio gear had to be raised and lowered outside of the tank and it was in the process of doing this that the FAC was wounded. See 'Mobile Director Posts in North West Europe' GHQ Home Forces, October 6, 1944.
- ⁷³ Terry Copp. A Canadian's Guide to the Battlefields of Normandy, p 105.

⁷⁴ Comparison of Rocket and bomb in Operation Overlord - 6 June to 28 June, 25 July, 1944. AIR 24/1528

⁷⁵ Ibid.

⁷⁶ Ibid.

⁷⁷ IMW 83/15/3

⁷⁸ 83 Group Intelligence Summary for July, 1944 IMW 83/15/3

⁷⁹ Ibid.

⁸⁰ Operational Record Book ORS/TAF Appendix 4, 21 June 1944. AIR 24/1528

⁸¹ Diary of Scientific Advisor to 21 Army Group, June 17 to June 23, 1944. WO 171/06 xc153148

⁸² Investigation of an Attack on a German Column near La Baleine No. 2 ORS Report No. 3, p 63.

⁸³ Ibid. p 61.

⁸⁴ AIR 41/67 p 76.

⁸⁵ 83 Group Intelligence Summary for August, 1944 IMW 83/15/3

⁸⁶ AIR 41/67 p 87.

⁸⁷ Ibid. p 89.

⁸⁸ Air Attacks on Enemy Tanks and Motor Transport in the Mortain Area, August 1944, Report No. 4 in Operational Research in North West Europe, 1951, p 65.

⁸⁹ Ibid. p 65.

⁹⁰ Ibid. p 66.

⁹¹ IWM 83/15/3

⁹² Ibid.

⁹³ The high loss rate of pilots and aircraft runs somewhat contradictory to the claims made by Gooderson in his book that missions flown close to the front were far less

dangerous than those flown deep behind the front line. His use of the OR material is highly selective and does not lend itself to sweeping generalizations but rather specific examples. (See Chapter 8 'The Cost Effectiveness of Close Air Support: A Comparison with Armed Reconnaissance')

⁹⁴ IMW 83/15/3

⁹⁵ Ibid.

⁹⁶ Ibid.

⁹⁷ Donald E. Graves. South Albertas, p 122.

⁹⁸ Ibid. p 125.

⁹⁹ Ibid. p 136.

¹⁰⁰ Enemy Casualties in Vehicles and Equipment during the retreat from Normandy to the Seine Report No. 15, ORS.

¹⁰¹ Ibid. p 74.

¹⁰² Ibid. Appendix C.

¹⁰³ Ibid. p 75.

¹⁰⁴ Ibid. p 77.

¹⁰⁵ Ibid. Appendix F.

¹⁰⁶ Ibid. p 79.

¹⁰⁷ Ibid. Appendix H.

¹⁰⁸ Ibid. p 81.

¹⁰⁹ IMW 83/15/3

Conclusion

Through the interwar period the development of a coherent and cooperative air support doctrine in the British military stagnated as the RAF and army approached the subject from diametrically opposed views. The RAF contended that the role of the air force was mainly in the realm of strategic bombing and defence against it. This meant priority in aircraft production for heavy bombers and air superiority fighters. In this way, it was argued, air power could assist the army by destroying the enemy's ability to produce weapons and perhaps ultimately cause him to capitulate in the face of devastation wrought on his cities and populous. The army would therefore be little more than a policing unit brought in to consolidate the victory won from the air. The army, however, having suffered more than the other the three services in the last war, was determined to ensure that attritional fighting did not bleed its divisions dry again. It was not convinced of the war winning potential of the heavy bomber and argued for

an air force that, similar to artillery, was on call to support ground forces by intervening directly on the battlefield. It therefore advocated the production of purpose built attack aircraft. When war came, however, it was the RAF concept of air power that triumphed, and the army made do with very limited air support.

With the defeat of the Luftwaffe during the Battle of Britain and the slow realization that strategic bombing was not going to bring Germany to its knees the prospect of another land campaign on the European continent loomed ever larger. By the summer of 1943 the army's views of air support came to the fore. The need was unmistakable, but the ability to fulfill the request for air support on the battlefield was limited. The legacy of the RAF pursuit of strategic bombing above all else, meant no dedicated ground attack aircraft had been built. The resultant compromise was to convert the now largely redundant squadrons of fighters, no longer required to defend Britain from German bomber formations, into a tactical air force assigned to support land operations on the continent.

The Second Tactical Air Force grew to include four groups. The one most important to the British Second Army was the one eventually paired with it, 83 Composite Group. As the name suggested the complement of aircraft in the group was mixed and although it changed periodically it was basically equipped with 10 Typhoon squadrons, 12 Spitfire Squadrons and 6 Mustang squadrons, all high performance fighters.¹ The problem facing the RAF was to support the army with the equipment at hand but neither the design of the aircraft nor the training of the pilots was appropriate to operate in this environment. In the year between 83 Group's creation and the commencement of operations in Normandy this fundamental problem

had to be overcome. In fact, it couldn't. What did occur however, and has to this day remained largely obscured, was nonetheless the provision of air support that aided materially in the overall defeat of the German army in Normandy but not in a way the army desired or even recognized.

D-Day, June 6, 1944 marked the beginning of the Normandy campaign and the start of a long and often bitter debate on tactical air power in the theatre that to this day remains controversial and misunderstood. It is now largely accepted that the 'Day of the Typhoon' and its tank killing prowess was more myth than reality but that Typhoons were still effective in assisting ground operations through what has been termed the 'morale effect.'

Much has been made in the historiography about the morale effect. Almost every writer on the subject has concluded that attacking aircraft created fear to some degree in enemy troops that reduced their ability to fight. But what is morale effect and does it accomplish what so many have attributed to it? A report of the British Informal Fire Effect Committee in March 1944 examined this very issue and attempted to better define the concept of fear and its relationship to weapons and their use on the battlefield.² The report noted that:

- With increased experience of a weapon, two parallel processes are occurring:-
- 1) "Habituation" - the loss of moral effect which comes from knowing what to expect
 - 2) "Sensitization" - the increase of moral effect which comes from the building up of respect and fear as the result of previous bitter experience.³

The following examples of each reaction illustrate how two identical attacks by aircraft could be met by two entirely opposite responses:

Like we were taught, I took up my weapon, loaded it, and began to track the daring fighters' flight [-] in came the first, engines howling, at great speed - "Brrt, drrt, brrt" - the cone of fire detonated on the road, a low level strafing! I took aim, just like in the training manuals, and - "brtschsch" - the burst is away. Meanwhile all around, the others have opened fire on the fighter.⁴

Sturmmann Helmuth Pock, 12th SS Hitler Youth Division

Unless a man has been through these fighter-bomber attacks he cannot know what the invasion meant. You lie there, helpless, in a roadside ditch, in a furrow on a field, or under a hedge, pressed into the ground, your face in the dirt - and there it comes toward you, roaring. There it is. Diving at you. Now you hear the whine of the bullets. Now you are for it.⁵

Hauptmann Alexander Hartdegen, Panzer Lehr Division

While the Committee posited the possible reactions to weapons they could not indicate which result would occur or at what frequency. From data gathered in other theatres of war, it was clear that a multitude of variables played a part in whether soldiers and units withstood attacks or ran from them. What the Committee was hoping to discover was why various weapons were feared and to what degree. Three reasons were given that, again, could address the issue of the morale effect of weapons on soldiers only in very general terms:

- a) Rational reasons - directly related to the fear of death or injury.
- b) "Rationalizations" - i.e. Reasons which sound rational, but which are based on assumptions which, whether the subject realizes it or not, are false, and ascribe to the weapon properties which it does not possess.
- c) Irrational reasons - i.e. factors springing from the deeper instinctive levels of the mind, and not particularly related to the objective "facts".⁶

Whatever the reasons for a soldier's reaction to a weapon, POW reports indicated that the strongest reaction was to cannon and machine gun fire.

attacks by M.G. and cannon-fire have the most detrimental effect on German morale, since the ground strafing fighter appears to be aiming directly at the individual. P/W class M.G. and cannon fire as the most feared form of attack, therefore, and follow this by R.P. attack, low level bombing and high level bombing in descending order of merit.⁷

This no doubt came as some surprise to allied planners, who had been apprised of the great morale effect rockets were supposed to have on enemy troops. The report also indicated that the “psychological effect of R.P.’s is stated to have been adversely affected by the fact that there has regularly been quite a high proportion of duds.”⁸ Clearly, this was a sign of habituation to a weapon considered the best and fiercest the tactical air forces employed. It is also worth noting that the Stuka, the infamous ‘terror bomber’, was equipped with sirens intended to add to the fear and confusion of troops being attacked by its unholy wailing but the Typhoon was never similarly modified. The reason is clear. The rocket equipped Typhoon was not envisioned as a ‘terror bomber’ but a dual purpose fighter-bomber primarily tasked with the destruction of armoured vehicles. Post war accounts and rationales that have since claimed otherwise are in fact rationalizations in reaction to empirical data that has shown the Typhoon’s ability to destroy armoured vehicles was poor indeed.

Another report on the subject, this one written a full five years after the end of the war reinforced the earlier findings that no clear assessment of the morale effect created by attacking aircraft was possible.

Attacks by fighters and fighter bombers were not usually immediately followed by the occupation of the enemy position and the taking of prisoners. Because of the time lag normally existing between experience of such attacks and capture, POW interrogation reports contain no worthwhile evidence of the morale effect of these attacks.⁹

This conclusion raises two important points. The first is that even if there was a morale effect there would also be sufficient time to recover from it because the attacks usually occurred far behind the lines. Secondly, as the POW reports were viewed with skepticism, both the positive and negative accounts above were therefore suspect. One might presume that the SS soldier's account would naturally be one of unflinching bravery while the army officer's version a reflection of his position as General Bayerlein's orderly officer and therefore inculcated with the army 'truth' that the lack of Luftwaffe protection was the cause of their defeat. Whether truthful or given with a specific agenda, each account demonstrates the dangers of drawing specific conclusions. However, the fact that the German army was able to fight a long and bitter campaign in Normandy in the face of such attacks would seem to suggest that whatever morale effect air attack evoked, it was insufficient to seriously hinder the German soldier's ability to fight when the time came. As one historian has noted, "it made relatively little difference to the advancing Allied troops if German machine-gunners were unhappy while firing their weapons."¹⁰ His conclusion that in the Normandy campaign German units rarely broke and ran "happened too rarely to be taken as a serious factor in the Allied victory" seems quite reasonable.¹¹

Despite such reports the overwhelming popular opinion of rocket firing Typhoons was and remains that of fearsome tank killer. In the Guns of Normandy George Blackburn remembered that:

The planes come in at full throttle without warning, four hundred miles an hour, and sometimes you miss seeing the first one dive. But the moment he releases his rockets, everybody across the entire front is aware that the Tiffies are operating. It must make the German's blood run cold, for even back here at the guns, three miles from the targets being attacked, the monstrous swoosh of the rockets ripping the air on their way down to the ground from the straining, diving planes can cause anxiety. Even after days of hearing them, the skin on the back of your neck tenses up whenever you hear the awesome scuroo-ching of the rockets descending. You never fail to watch, for each pilot puts on a truly magnificent display of courage that is silently applauded by thousands of other watching Allied soldiers.¹²

In fact, what Blackburn is describing is the other side of morale effect, the positive one conferred on Allied troops who were able to witness such attacks at close quarters. If such displays encouraged many Allied soldiers in the attack then it seems equally undeniable that when faced with the unhappy but still effective German machine gunner what encouragement they might have received evaporated as they came up against opposition not eliminated from the air.

While this effect has not and will probably never be adequately quantified, there is no question that the constant threat and experience of air attack by fighters and fighter-bombers had some impact on German morale. The current debate on air support in Normandy has now shifted to this issue. While useful, the fact is that ground attack or direct/close air support and whatever subsequent morale effect it may have produced was not the focus of 83 Group and indeed their day by day operations prove this. The primary role of 83 Group in providing air support to British 2nd Army was in the maintenance of air superiority over the battlefield so that the ground forces could conduct operations relatively unhindered by the Luftwaffe. That this was so is reflected in 83 Group's division of sorties.¹³ Approximately half of all missions flown

during the campaign were concerned with defense against enemy aircraft, not enemy ground forces. Actual ground attack missions deemed direct/close support that involved direct intervention on the field of battle accounted for only 20% of all sorties flown. The bulk of the remaining sorties were armed reconnaissance missions that ranged far behind enemy lines, with the intent of interdicting supplies to the front and gathering information. Therefore what one sees in the Normandy campaign is a mode of air support to the army that focused more on a protective screen than an offensive punch. This reflected the limitations of the pilots and aircraft, as well as their strengths.

Effort expended on obtaining and maintaining Air Supremacy¹⁴

Month	Number of effective sorties flown by all groups					
	Offensive Patrols	Inter-ception	Escort	Total	85 Group	83 and 84 Group
June	4,716	4,692	3,134	12,542	1,488	11,054
July	4,548	135	3,869	8,552	1,294	7,258
August	1,035	3,009	2,751	6,795	916	5,879
Totals	10,299	7,836	9,754	27,889	3,698	24,191

(Table 4.1)

Sorties by Aircraft of 2 TAF during the Normandy Campaign¹⁵

Month	Medium & Light Bombing	Fighter Escort & Patrols	Fighter Bomber & RP attacks*	Armed Recce	Photo, weather visual and tactical recce and ASR	Total
June	3,117	18,062	7,652	5,277	3,810	37,916
July	3,304	14,528	6,484	5,527	3,025	32,868
August	3,990	7,325	3,850	14,169	3,918	33,252
Totals	10,411	39,915	17,986	24,973	10,753	104,036

*Refers to pre-arranged attacks against ground targets and immediate support/close support. (Table 4.2)

Excluding the light and medium bombers and focusing just on the fighter aircraft one can see that for the first two months of the campaign over 50% of all fighter sorties were air superiority missions in some form. When the month of August is included the total drops to 42%, still far and away the single largest number of sorties flown by the fighters in the composite groups in 2 TAF. The actual percentage of missions termed direct or close air support was just 19% of the total effort expended. That bears repeating. Less than 20% of all fighter and fighter/bomber sorties flown through the entirety of the Normandy campaign were of the specific type, direct/close support, that the army wanted. The remaining 80% followed the doctrine argued by the RAF, support through air superiority, interdiction and intelligence gathering. The importance of this finding cannot be understated. The debate waged over the effectiveness of the rocket Typhoons and their accuracy and resultant impact on the battlefield has focused entirely in the wrong area and on the wrong criteria. To understand what tactical air power did in the campaign the data clearly requires that one determine what the majority of sorties were and what those sorties accomplished either by what they did, or what they prevented. It was the fighter, not the fighter-bomber, that supplied the majority of the support to the ground forces.

Of the 403 enemy aircraft claimed destroyed by pilots in 83 Group during the entire Normandy campaign, not one was shot down by a Typhoon.¹⁶ Despite being trained as fighter pilots first and foremost, despite being equipped with single engine fighter aircraft and despite operations in a hostile environment for three months the Typhoons of 83 Group claimed no air-to-air kills at all. Spitfire and Mustang squadrons, often flying right along side them, did all the damage to the Luftwaffe.¹⁷ Coupled with the

other evidence already presented it seems clear that the duality of the fighter-bomber is a myth, there were fighters and there were bombers but rarely, if ever, were they one and the same aircraft. Such evidence highlights the question of why a dedicated ground attack aircraft was never produced. In retrospect it appears that the Typhoon could have been modified with the addition of heavy armour plating to increase its survivability and a bomb/rocket sight to improve accuracy, especially since it was often escorted by Spitfires and Mustangs when undertaking ground attacks. That this wasn't done is a reflection, in part, of RAF doctrine and reluctance to become too closely tied to the battlefield.

The examination of results by squadron also indicates the actual effort expended by the various aircraft types in the fighter and fighter-bomber role. Despite the efforts to equip Spitfires with bombs in the month of August 1944, 12 squadrons dropped just 747 bombs compared with the 3,415 dropped by the 3 Typhoon squadrons and the 1,909 dropped by 3 Mustang squadrons.¹⁸

The data does support the contention put forth in this paper that the duality of the fighter-bomber was never fully realized if indeed it was feasible in the first place. Clearly the Spitfire dropped very few bombs, fired no rockets yet claimed the highest number of enemy transport destroyed of any aircraft in 83 Group. Even taking into account the strong likelihood of inflated claims it seems apparent that it was the canon and machine gun of the Spitfire that proved the most effective in ground attack, in other words strafing. As has been shown, the wing mounted canon and machine gun in the single engine fighter were the most accurate weapon system on the aircraft and the only weapon the aircraft had initially been designed to carry. The addition of

rockets and bombs was done post production and a dedicated sight for either weapon was not available during the campaign.

An examination of fighter-bomber results against specific targets was quite revealing in what damage they were able to inflict.

Attacks by fighters and fighter bombers on Gun Positions, HQs etc. which were checked by ground observers afterwards¹⁹

Target	Fighter-Bombers			RP Fighters		
	No. of Sorties	Bombs Dropped	Findings	No. of Sorties	No. of rockets fired	Findings
Gun Positions	24	34 x 500lb 10 x 100lb	11 casualties	201	1498	24+ casualties 1x3.7 gun and 2x88mm guns dest. Amm. Blown up. Houses dest. on 7 occasions. 1 Range finder dam. Wood set on fire
HQs	341	162 x 100lb 246 x 500lb 40 x 250lb	86 +casualties 12 HQs dam. or gutted 4+houses dest.	168	1190	30 casualties 4 HQs dest. Houses dest. on 3 occasions
Strong points	47	67 x 500lb	4 houses dest. 1 x 88mm and 1 x 105mm dam. 1 x 105mm dest.	57	447	6 casualties 13 houses dest. Houses dest. and dam. on 2 occasions.
Misc. Targets	120	18 x 1000lb 128 x 500lb 72 x 250lb	1 half track dest. 3 houses dest.	68	320	1 casualty 1 dump gutted Buildings dam.

(Table 4.3)

It was dryly observed “that although the material destruction caused by fighter and fighter-bomber attacks was not very great, it was as great as could be expected.”²⁰

And herein lies the root of the problem that has surrounded the debate of the effectiveness of tactical air power in the Normandy campaign. Historians who have

focused so intently on whether Typhoons could hit tanks with rockets and, if not, at least demoralize the crew inside, have in essence been arguing the army side of the debate. The importance of tactical air power was not in direct/close support but in defensive support. Focusing exclusively on direct/close support problems ignores the real and substantial contribution tactical air power brought to the battlefield and ensures the debate stays mired in controversy. Looking at the campaign in total it mattered little how many tanks and strong points fighter-bombers destroyed but rather how effective they were in keeping the Luftwaffe away from the ground forces, denying the enemy movement of vehicles in daylight and limiting German mobility by attacks on all forms of transportation. There is no doubt that 83 Group successfully carried out the tasks it was trained and equipped to accomplish.

End Notes to Conclusion

¹ See Appendix A.

² 'The Moral Effect of Fire' Informal Fire Effect Committee, 9 March, 1944. WO 32/10375

³ Ibid.

⁴ Robert Kershaw. D-Day: Piercing the Atlantic Wall, p 194.

⁵ Ibid. Kershaw. p 197.

⁶ Ibid. WO 32/10375

⁷ The Effect of Air Attack. Air Ministry Intelligence Report No. 382/1944, 24 July, 1944, p 1. AIR 37/760

⁸ Ibid AIR 37/760 170816, p 2.

⁹ Army Operational Research Group Internal Memorandum No. A8 The Effects of Close Air Support Fighters and Fighter Bombers in N.W. Europe, February 1950, p 13. WO 291 1178

¹⁰ Vogel. p 45.

¹¹ Ibid.

¹² Blackburn. p 228.

¹³ See Table 4.1 and 4.2

¹⁴ 2TAF/ORS Report No. 30 July 1945. WO 291 1357 xc164669

¹⁵ Ibid.

¹⁶ IMW 83/15/3 and Thomas and Shores The Typhoon and Tempest Story, Appendix 3 'Claims'.

¹⁷ Ibid

¹⁸ Ibid.

¹⁹ WO 291 1178, p 8.

²⁰ **ibid.**

No. 83 (Composite) Group, 2nd TAF
Allocation of Squadrons and Airfield Headquarters
to Wings after Disbandment of No. 16 Wing (4 April, 1944)

	Airfield HQ 122	19 Mustang III 65 Mustang III 122 Mustang III
Fighter Wing 15	Airfield HQ 125	132 Spitfire IX 602 Spitfire IX 433 (RAAF) Spitfire IX
	Airfield HQ 129 RCAF	137* Typhoon IB 184 Typhoon IB
	Airfield HQ 126 RCAF	401 Spitfire IX 411 Spitfire IX 412 Spitfire IX
Fighter Wing 17 RCAF	Airfield HQ 127 RCAF	403 Spitfire IX 416 Spitfire IX 421 Spitfire IX
	Airfield HQ 144 RCAF	441 Spitfire IX 442 Spitfire IX 443 Spitfire IX
	Airfield HQ 121	174 Typhoon IB 175 Typhoon IB 245 Typhoon IB
Fighter Wing 22 RCAF	Airfield HQ 124	181 Typhoon IB 182 Typhoon IB 247 Typhoon IB
	Airfield HQ 143 RCAF	438 Typhoon IB 439 Typhoon IB 440 Typhoon IB
39 Recce Wing RCAF	Airfield HQ 128 RCAF	400 (PR) Spitfire PRXI/Mos. PRIX/XVI 168 Mustang I 414 Mustang I 430 Mustang I

*137 Squadron to be transferred from ADGB to 2nd TAF later under AEF instructions.
 (Chart refers only to fighter and fighter-bomber aircraft)

AIR 37/102 170975 No. 83 (Composite) Group, 2nd TAF Organization Chart, April 1944.

Summary of 83 Group Operations Claims by Aircraft Type in the Normandy Campaign June - August 1944

3 Mustang III Squadrons

Month	Sorties	Bombs	R.P.	Tanks		MET		Enemy Aircraft			Losses	
				Des.	Dam.	Des.	Dam.	Des.	Prob.	Dam.	Aircraft	Pilots
June	1,344	1,692	0	0	0	92	63	36	0	17	15	15
July	1,232	1,016	0	0	0	24	44	28	2	24	11	9
August	1,805	1,909	0	1	4	151	444	21	3	15	19	14
Totals	4,381	4,617	0	1	4	267	551	85	5	56	45	28

12 Spitfire Mk IX Squadrons

Month	Sorties	Bombs	R.P.	Tanks		MET		Enemy Aircraft			Losses	
				Des.	Dam.	Des.	Dam.	Des.	Prob.	Dam.	Aircraft	Pilots
June	7,369	350	0	0	5	296	328	106	9	50	47	34
July	9,652	294	0	1	27	405	777	161	11	94	46	40
August	8,483	747	0	0	22	1,826	3,288	39	3	17	52	34
Totals	25,504	1,391	0	1	54	2,527	4,393	306	23	161	145	108

10 Typhoon 1B Squadrons RP and Bomb

Month	Sorties	Bombs	R.P.	Tanks		MET		Enemy Aircraft			Losses	
				Des.	Dam.	Des.	Dam.	Des.	Prob.	Dam.	Aircraft	Pilots
June	3,458	2,029	11,830	17	8	141	52	0	0	0	31	23
July	3,094	2,290	15,351	39	61	60	70	0	0	0	28	22
August	4,703	3,415	19,264	215	179	1,227	1,386	0	0	1	55	48
Totals	11,255	7,734	46,445	271	248	1,428	1,508	0	0	1	114	93

(IMW 83/15/3 83 Group Intelligence Summaries)

Summary of 83 Group Operations Claims by Aircraft Type in the Normandy Campaign June - August 1944

3 Mustang I Squadrons Tactical Photo Reconnaissance

Month	Sorties	Bombs	R.P.	Tanks		MET		Enemy Aircraft			Losses	
				Des.	Dam.	Des.	Dam.	Des.	Prob.	Dam.	Aircraft	Pilots
June	1,120										4	3
July	1,465					5		1			2	2
August	1,413					1	4	1		2	3	1
Totals	3,998					6	4	2		2	9	6

1 Composite Squadron Spitfire and Mosquito Strategic Photo Reconnaissance

Month	Sorties	Bombs	R.P.	Tanks		MET		Enemy Aircraft			Losses	
				Des.	Dam.	Des.	Dam.	Des.	Prob.	Dam.	Aircraft	Pilots
June	139											
July	144										1	
August	248											
Totals	531										1	

Grand Totals for all 83 Group Squadrons

Month	Sorties	Bombs	R.P.	Tanks		MET		Enemy Aircraft			Losses	
				Des.	Dam.	Des.	Dam.	Des.	Prob.	Dam.	Aircraft	Pilots
June	13614	4071	11830	18	17	552	468	143 ½	9	69	107	78
July	17643	2487	19349	49	97	516	936	197	13	123	110	92
August	19012	7295	25181	268	344	3347	5329	63	6	35	140	104
Totals	50269	13853	56360	335	458	4415	6733	403 ½	28	227	357	274

(IMW 83/15/3 83 Group Intelligence Summaries)

Appendix C

German Anti-Aircraft Guns

Anti Aircraft Artillery Piece	Rate of Fire (rpm)		Max Range (in metres)		Muzzle Velocity (in m/s)	
	Cyclic	Practical	Ground	Air	AP	HE
2cm Flak 30	280	120	4800	2200	830	900
2cm Flak 38	480	220	4800	2200	830	900
2cm Flak Vierl mg 38	1800	800	4800	2200	830	900
3.7cm Flak 18	160	80	6500	3500	770	820
3.7cm Flak 36 37	160	120	6500	3500	770	820
3.7cm Flak 43	250	180	6500	3500	770	820
8.8cm Flak 18	-	15 - 20	14680	10600	795	820
8.8cm Flak 36 37	-	15 - 20	14680	10600	795	820
8.8cm Flak 41	-	20 - 25	20000	12350	980	1000

(German Army Handbook 1939 - 1945 by WJK Davies Arco Publishing New York 1973 p 115.)

GUN ARMAMENT OF THE DIFFERENT TYPES OF AIRCRAFT USED IN 83 GROUP, 2ND T.A.F.

Aircraft	Gun Armament			Total Number of Rounds of Ammunition by Types			Proportions of Ammunition			
	.303	.500	20mm	.303	.500	20mm	.303	.500	20mm	Type of Gunsight
Spitfire IXA & B	4 Mk IIx		2 Mk IIx	1,400		290	50% AP 50% Inc.		50% SAP/I 50% HE/I	Gyro Gunsight Mk IID
Spitfire IXE		2 Mk II	2 Mk IIx		500	290		50% AP 50% Inc.	50% SAP/I 50% HE/I	Gyro Gunsight Mk IID
Mustang III		4 Mk II			1,260			50% AP 50% Inc.		Pilot's Reflector Sights Mk IIx or American N3-B
Typhoon IB			4 Mk IIx			576			50% SAP/I 50% HE/I	Pilot's Reflector Sights Mk IIx or Mk IIL

(‘Aircraft Armament Equipment of 2nd Tactical Air Force Review of Performance in N.W. Europe from June 1944 - May 1945’ Appendix G. AIR 37/838 168909)

Note: All guns installed in the above listed aircraft are fixed firing forward and are mounted internally in the wings.

Spitfire Mk IXc

Specifications

Maximum Speed 39 ft. 10 in. height 21 ft. 6 in. in level flight, 37 ft. 6 in. in steep climb; height 22 ft. 7 in. in steep climb; empty 5,200 lb., normal load 7,200 lb., maximum 8,200 lb.

Performance: Maximum speed 400 m.p.h. at 20,000 ft., 310 m.p.h. sea level, normal operating speed 280 m.p.h. at 20,000 ft., initial rate of climb 4,200 ft. per min. Time to 20,000 ft. 5.7 min. Service ceiling 42,000 ft. Service speed (normal load) 33 m.p.h. above and underneath sea. 70 m.p.h. above and underneath enemy.

Armament: 12 ft. or 10 ft. wings, machine guns to total 10 on 1,200 lb. or below load.

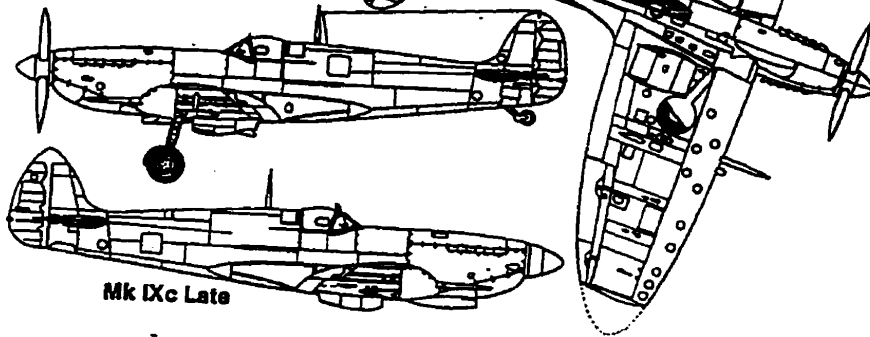

Mk IXc Late

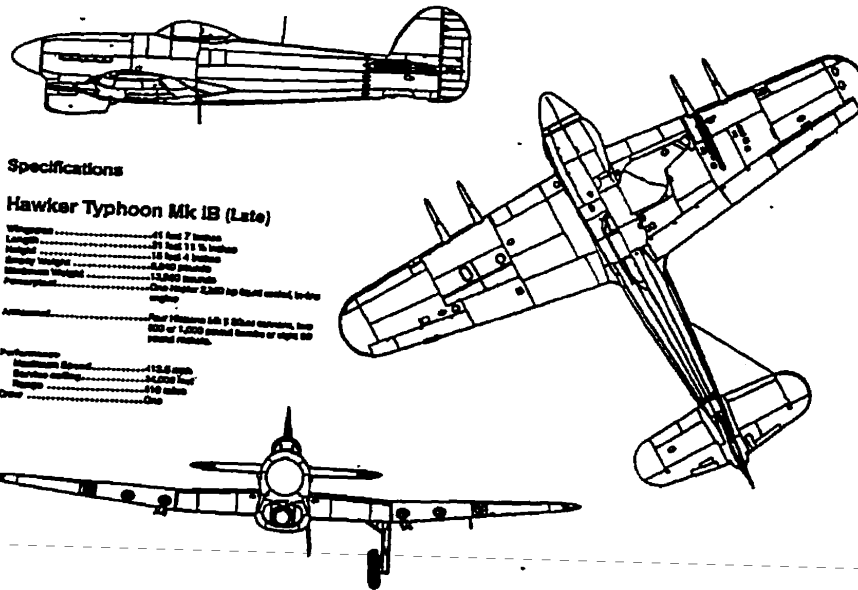

Specifications

Hawker Typhoon Mk IB (Late)

Wingspan 41 feet 7 inches
 Length 37 feet 11 1/2 inches
 Height 14 feet 4 inches
 Empty weight 8,200 pounds
 Maximum weight 12,000 pounds
 Armament One Vickers 2,000 hp turret, twelve machine guns

Altitude Four Vickers Mk II 500-calibre machine guns, two 500 or 1,000 pound bombs or eight 50 pound rockets.

Performance: Maximum speed 310 m.p.h.
 Service ceiling 42,000 feet
 Range 1,100 miles
 Climb One

P-51B-C/Mustang III

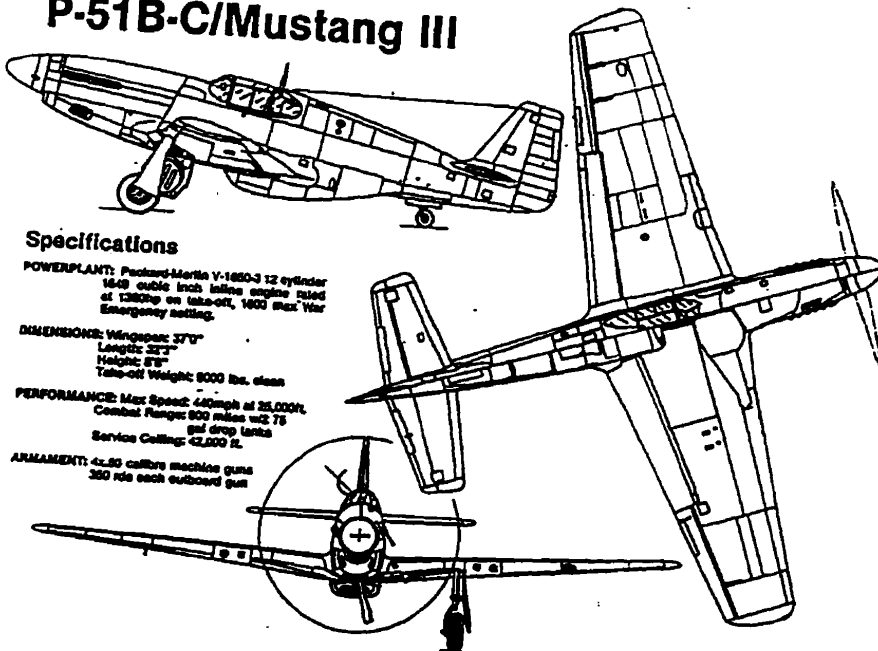

Specifications

POWERPLANT: Packard-Meritt V-1650-3 12 cylinder 1648 cubic inch liquid engine rated at 1380hp on take-off, 1000 max. War Emergency setting.

DIMENSIONS: Wingspan: 37'0"
 Length: 32'7"
 Height: 8'8"
 Take-off Weight: 8000 lbs. clean

PERFORMANCE: Max Speed: 440mph at 25,000ft.
 Combat Range: 800 miles w/2.75 gal drop tanks
 Service Ceiling: 42,000 ft.

ARMAMENT: 4x.50 calibre machine guns
 350 rps each outboard gun

Bibliography

Primary Sources

Air Officer Commanding in Chief, Fighter Command to Groups. January 24, 1942. AIR 16/776

A Summary of Recent Exercises within Fighter Command. August 1942. AIR 16/776

'Air Cooperation with Armoured Formations' H.Q. 21 Army Group, January 19, 1944. WO 205/535 114125

Air Support and Air Reconnaissance Aspects of Combined Operations in North West Europe, June 1944 - May 1945, Air Historical Branch, 1947. WO 233/61 xc7225

Aircraft Armament Equipment of 2nd Tactical Air Force - Review of Performance in N.W. Europe from June 1944 - May 1945. AIR 37/838 168909

'Armed Recce. By Aircraft of 2nd TAF in the Western European Campaign' 2nd TAF/ORS Report No. 30, July 1945. WO 291/1357 xc164669

Army Air Training Instruction - No.1 1943 Army Air Operations. The Chief of the Imperial General Staff and the Chief of the Air Staff, July 1943. AIR 8/988 92396

Army/Air Operations Pamphlet No. 2 'Direct Support' 1944. Chief of the Imperial General Staff and Chief of the Air Staff, April 1944. DND DHist 94/142

'Artillery Positions as Targets for Army Support Aircraft' Fighter Command, Tactical Memorandum No. 30. March 1943.

No. 83 (Composite) Group, 2nd TAF Organization Chart, April 1944. AIR 37/102 170975

'Air Attacks on Enemy Tanks and Motor Transport in the Mortain Area, August 1944'. ORS Report No. 4.

BIGOT Notes on Stanmore Meeting No. 4, May 31, 1944. AIR 37/1126

Comparison of Rocket and Bomb in Operation OVERLORD - 6 June to 28 June 1944. July 25, 1944 AIR 24/1528

Cutler, Able Seaman W. Personal Diary kept while aboard HMS Largs off of Sword Beach, June 1944. IMW 89/3/1

Diary of Scientific Advisor to 21 Army Group, June 17 to June 23, 1944. WO 171/06
xc153148

Effect of Enemy L.A.A. on British Fighter Bombers, 15 June 1944. Army Operations
Research Group Memorandum No. 340 WO 291/671

Efficacy of R.P. and 40mm Weapons Report H.Q. Fighter Command, August 3,
1943. AIR 16/705 00074

Employment of Bombers and Fighter Bombers in Cooperation with the Army May 6,
1944. AIR 20/3213

Fighter Attack of Armoured Fighting Vehicles Air Ministry, Air Tactics, May 1942.
AIR 23/1861 9918

Fighter Attack on Locomotives D. Armaments D. Trial Interim Report, Appendix C
AIR 16/705 00074

GHQ Directive on Training in Co-operation with the RAF. 30 April, 1942. AIR
16/552 xc153917

Letter: Barratt to Carr. HQ Eastern Command. March 13, 1942. AIR 39/129

Letter: Chief of Staff. May 16, 1943

Memorandum on the Air Aspects of Operations as it Affects 21 Army Group, October
1943. WO 233/24 155624

Memorandum to Generals Dempsey, Crerar, Bradley and Patton General B.L.
Montgomery, May 1944. AIR 37/1237 xc154927

Minutes of Air Ministry Planning Committee February 28, 1935. AIR 9/6 131884

Mobile Director Posts in North West Europe GHQ Home Forces, October 6, 1944.

ORS Assessment of Attacks on Small Targets by Fighter Type Aircraft, May 20,
1944. AIR 37/497 00019

ORS (ADGB) Report No. 41 Operational R.P. Tactics, March 30, 1944. AIR 37/497
xc155046

Operational Record Book ORS/TAF Appendix 4, 21 June 1944 AIR 24/1528

Relative Bombing Efficiency - Actual Results to be Expected Through Improved Strategy, Tactics and Equipment. Air Staff, October 14, 1942. AIR 20/3360 xc184616

Report by Air Marshal Sir Arthur Coningham, KCB, DSO, MC, DFC, AFC Concerning Operations Carried Out by Second Tactical Air Force Between 6th June 1944 and 9th May 1945. November, 1945. AIR 37/876

Report No. 501 RHUBARB Operation - Results Achieved and Losses Suffered January - July 1943 ORS Fighter Command, October 12, 1943. AIR 16/1044 136304

Report on Air Attacks on Locomotives H.Q. 2nd Tactical Air Force, September 12, 1943. AIR 37/826 168868

Report on Army Air Support Trials at RAF Station Digby with No. 7 A.A.S.C. Fighter Command, May 18, 1942. AIR 16/552 xc153917

Report on the Army Requirement of the Royal Air Force for Direct Support in Battle, Appendix B. The War Office, Scientific Advisor's Department, November 30, 1942. AIR 14/3946

'Standardized Briefing for Fighter and Fighter-Bomber Aircrews'. Headquarters 2 TAF, Air Staff Instruction, 15 May 1944. AIR 37/651 168896

'Tactics Used by Spitfire Day Fighter/Bomber Squadrons of the 2nd Tactical Air Force During the Campaign in Western Europe'. Tactical Paper No. 4, Air Historical Branch, 1947. AIR 20/6857 92550

'Tactics Used by Squadrons of the 2nd Tactical Air Force during the Campaign in Western Europe'. Air Historical Branch, 1947. AIR 37/835 168909

'Tactics Used by Typhoon Day Fighter/Bomber Squadrons of 2nd Tactical Air Force'. Air Historical Branch, 1947. AIR 37/835

'The Accuracy of Attacks on Small Targets by Fighter-Bombers and R.P. Fighters' ORS/AEAF Report No. 16 June 10, 1944.

'The Effect of Air Attack'. Air Ministry Intelligence Report No. 382/1944. July 24, 1944. AIR 37/835 168909

'The Effects of Close Air Support Fighters and Fighter Bombers in N.W. Europe' Army Operational Research Group Internal Memorandum No. A8, February 1950. WO 291/1178 121054

'The Employment of Bombers and Fighter-Bombers in Co-operation with the Army', Allied Forces Headquarters - Mediterranean May 6, 1944. AIR 2/7870 113691

The Liberation of North West Europe. Air Historical Branch. AIR 41/24 169523

'The Moral Effect of Fire' Informal Fire Effect Committee, March 9, 1944. WO 32/10375

'The Normandy Invasion - June, 1944' German Air Historical Branch, August 6, 1944. DND DHist SGR II 264, Folder 18

'The Use of the Hurricane Bomber' H.Q. Fighter Command, Tactical Memorandum No. 13, Appendix A, August 29, 1941. PRO 16/334 xc3848

The Use of the Spitfire-Bomber (Bombfire) H.Q. Fighter Command, Air Tactics, March 16, 1943. A5218 #598

Training Syllabus Summary of Flying Training Exercises - Single Engined Ground Attack Pilots (Typhoon), 1944. AIR 16/493 9991

Visit of A.O.A. 2nd Tactical Air Force to 83 Group Overseas, 23 June - 24 June 1944. AIR 37/79 xc170903

83 Group Intelligence Summaries 1943 and 1944 (Month by month) contained in papers of Squadron Leader R. T. Wilkins. IMW 83/15/3

Secondary Sources

Air Ministry (British). The Origins and Development of Operational Research in the Royal Air Force. Her Majesty's Stationary Office, 1963.

Anonymous. 'Hawker Typhoon' in *The Aeroplane*, February 11, 1944 reproduced in Hawker Typhoon Portfolio. Hong Kong: Brookland Books, 1986.

Berger, Monty and Brian Jeffrey Street. Invasions Without Tears: The Story of Canada's Top-Scoring Spitfire Wing in Europe During the Second World War. Toronto: Random House, 1994.

Bickers, Richard Townshend. Air War Normandy. London: Leo Cooper, 1994.

Blackburn, George C. The Guns of Normandy: A Soldier's Eye View, France 1944. Toronto: McClelland and Stewart, 1995.

- Blackmore, L.K. Hawker: A Biography of Harry Hawker. Shrewsbury, England: Airlife Publishing, 1990.
- Bracken, Robert. Spitfire: The Canadians. Erin, Ontario: The Boston Mills Press, 1995.
- Carrington, C.E. Air Liaison Officer. Unpublished Manuscript, Date Unknown.
- Clarke, R.M. Hawker Typhoon Portfolio. Hong Kong: Brooklands Books, 1986.
- Copp, Terry. The Brigade: The Fifth Canadian Infantry Brigade, 1939 - 1945. Stoney Creek, Ontario: Fortress Publications, 1992.
- Copp, Terry and Robert Vogel. Maple Leaf Route: Falaise. Alma, Ontario: Maple Leaf Route, 1983.
- Davies, W.J.K. German Army Handbook, 1939 - 1945. New York: Arco Publishing, Inc., 1973.
- Davis, Larry. P-51 Mustang in Action. Carrollton, Texas: Squadron/Signal Publications, 1981.
- Delve, Ken. D-Day: The Air Battle. London: Arms and Armour Press, 1994.
- Dunmore, Spencer. Above and Beyond: The Canadian's War in the Air, 1939 - 45. Toronto: McClelland and Stewart, 1996.
- Ellis, Major L.F. Victory in the West: The Battle of Normandy, Volume One. London: Her Majesty's Stationery Office, 1962.
- Godefroy, Hugh. Lucky 13. Toronto: Stoddart Publishing, 1983.
- Gooderson, Ian. Air Power at the Battlefield: Allied Close Air Support in Europe, 1943 - 45. London: Frank Cass, 1998.
- Granatstein, J.L. and Desmond Morton. Bloody Victory: Canadians and the D-Day Campaign. Toronto: Lester & Orpen Dennys Limited, 1984.
- Graves, Donald E. South Albertas: A Canadian Regiment at War. Toronto: Robin Brass Studio, 1998.
- Greenhous, Brereton et.al. The Crucible of War, 1939 - 1945: The Official History of the Royal Canadian Air Force Volume III. Toronto: University of Toronto Press, 1994.

_____. 'Mythology, Technology and Aircraft in an Anti-Armor Role Before 1945' presented at International Conference on Military History, Washington D.C., August 14-19, 1975.

_____. 'The Effectiveness of Aircraft v. Armor in the Battle of Normandy, 1944'. Unpublished Paper, date unknown.

Gunston, Bill. World War II British Aircraft. London: Leisure Books, 1985.

Halley, James J. The Role of the Fighter in Air Warfare. New York: Ziff-Davis Publishing Company, 1978.

Halliday, Hugh A. Typhoon and Tempest: The Canadian Story. Toronto: CANAV Books, 1992.

Hallion, Richard. Strike From the Sky: The History of Battlefield Air Attack 1911 - 1945. Shrewsbury: Airlife Publishing, 1989.

_____. D-Day 1944: Air Power Over the Normandy Beaches and Beyond. Air Force History and Museums Program, 1994.

Hess, W.N. The Allied Aces of World War II. New York: ARCO Publishing Co., 1966.

Hess, William and Thomas Ivie. Fighters of the Mighty Eighth. Osceola, Wisconsin: Motorbooks International, 1990.

Hinsley, F.H. British Intelligence in the Second World War: Its Influence on Strategy and Operations. Volume Three, Part II. London: Her Majesty's Stationery Office, 1988.

Historical Evaluation and Research Organization. A Historical Analysis of the Effectiveness of Tactical Air Operations Against, and in Support of, Armored Forces. Prepared for Sandia National Laboratories, October, 1980.

Jacobs, W.A. 'Air Support for the British Army, 1939 - 1945' in *Military Affairs*, December, 1982.

_____. 'The Battle for France' in Case Studies in the Development of Close Air Support. Editor Benjamin Franklin Cooling. Washington, DC: Center for Air Force History, 1990.

_____. 'Operation OVERLORD' in Case Studies in the Achievement of Air Superiority. Editor Benjamin Franklin Cooling. Washington, DC: Center for Air Force History, 1994.

- Johnson, J.E. and P.B. Lucas. Courage in the Skies: Great Air Battles from the Somme to Desert Storm. London: Random House, 1992, 1996.
- Kershaw, Robert J. D-Day: Piercing the Atlantic Wall. Surrey: Ian Allan Publishing, 1993.
- Lefevre, Eric. Panzers in Normandy: Then and Now. London: Battle of Britain Prints International Limited, 1983.
- Leigh-Mallory, Air Chief Marshal Trafford. 'Operations by the Allied Expeditionary Air Force in N.W. Europe' in the *London Gazette*, Special Supplement, January 1947, section 325.
- Lewin, Ronald. Ultra Goes to War. London: Hutchinson, 1981.
- Meyer, H. Kriegsgeschichte der 12 SS Panzerdivision "Hitlerjugend" Osnabrueck, 1987.
- Murphy, Geoffrey and Jean Pierre Benamou. Normandie 1944: La 2nd Tactical Air Force. Bayeux, France: Editions Heimdal, 1989.
- Murray, Williamson. Luftwaffe. Baltimore, Maryland: The Nautical & Aviation Publishing Co., 1985.
- Nesbit, Roy Conyers. Eyes of the RAF: A History of Photo-Reconnaissance. Godalming, Surrey: Bramley Books, 1996, 1997.
- Olmsted, Bill. Blue Skies: The Autobiography of a Canadian Spitfire Pilot in World War II. Toronto: Stoddart Publishing, 1987.
- Price, Alfred. Spitfire: A Complete Fighting History. England: Promotional Company Reprint Ltd., 1974, 1975.
- Rawlings, John. Fighter Squadrons of the RAF and their Aircraft. Bodmin, Cornwall: Crecy Books, 1968, 1993.
- Reed, Arthur and Roland Beamont. Typhoon and Tempest at War. Surrey: Ian Allan Ltd., 1974.
- Rimel, Raymond Lawrence. R.A.F. Between the Wars. London: Arms and Armour Press, 1985.
- Robinson, Douglas. 'Strategic Bombing' in Warplanes & Air Battles of World War I, edited by Bernard Fitzsimons. London: BPC Publishing Ltd., 1973.

Scutts, Jerry. Spitfire in Action. Carrollton, Texas: Squadron Signal Publications Inc., 1980.

Scutts, Jerry. Typhoon/Tempest in Action. Carrollton, Texas: Squadron Signal Publications Inc., 1990.

Shores, Christopher. Second Tactical Air Force. London: Osprey, 1970.

_____. Ground Attack Aircraft of World War II. London: Macdonald and Jane's Limited, 1977.

_____. History of the Royal Canadian Air Force. Toronto: Royce Publications, 1984.

Simonds, Peter. Maple Leaf Up - Maple Leaf Down: The Story of the Canadians in the Second World War. New York: Island Press, 1946.

Smith, Malcolm. British Air Strategy Between the Wars. Oxford: Clarendon Press, 1984.

Smith, Peter C. Close Air Support: An Illustrated History, 1914 to the Present. New York: Crown Publishers Inc, 1990.

Stacey, Col. C.P. 'Official History of the Canadian Army in the Second World War.' Volume III The Victory Campaign: The Operations in North West Europe, 1944 - 1945. Department of National Defence, Queen's Printer, 1960.

Tanner, John. Fighting in the Air: The official combat technique instructions for British fighter pilots, 1916 - 1945. London: Arms and Armour Press, 1978.

Tedder, Air Chief Marshal Arthur W.T. Air Power in War. London: Hodder and Stoughton, 1948.

Terraine, John. The Right of the Line: The Royal Air Force in the European War, 1939 - 1945. London: Hodder and Stoughton, 1985.

Thomas, Chris and Christopher Shores. The Typhoon and Tempest Story. London: Arms and Armour Press, 1988.

Vanags-Baginskis, Alex. Aggressors: Tank Buster vs. Combat Vehicle. Tokyo: Zokeisha Publications Ltd., 1990.

Vogel, Robert. 'Tactical Air Power in Normandy: Some Thoughts on the Interdiction Plan' in *Canadian Military History*, Volume 3, Number 1, Spring 1944.

IMAGE EVALUATION TEST TARGET (QA-3)

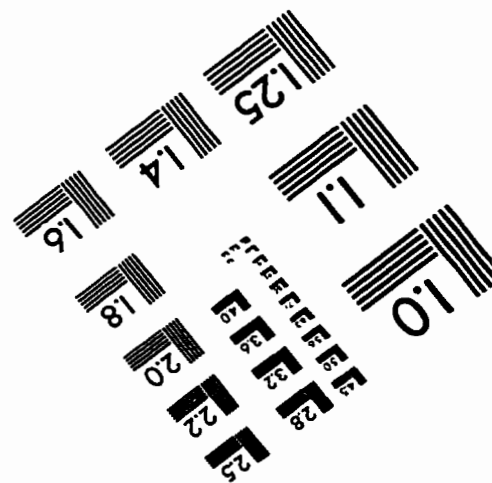
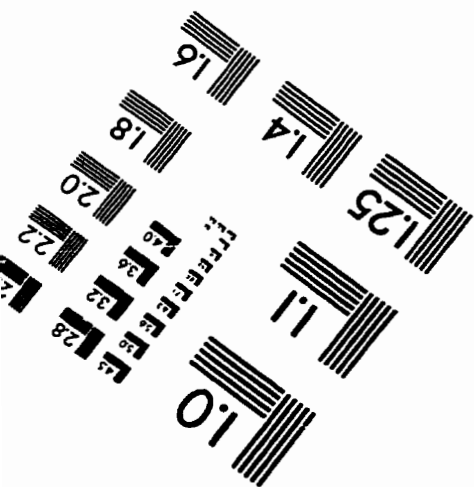
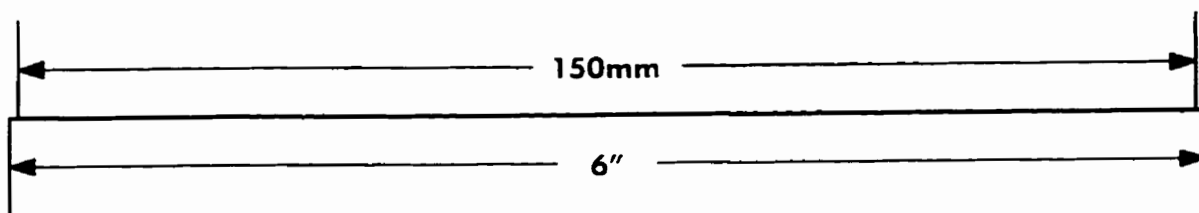
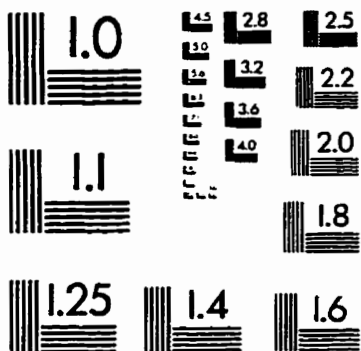
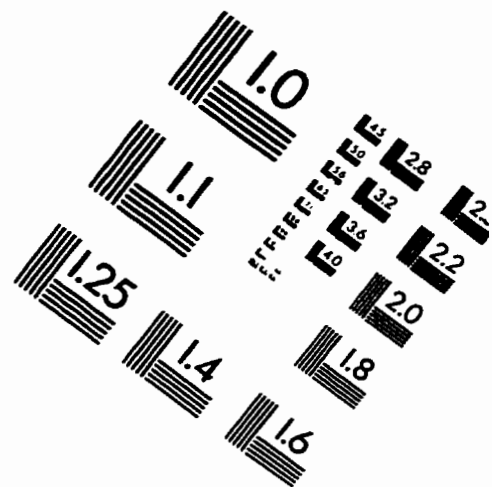
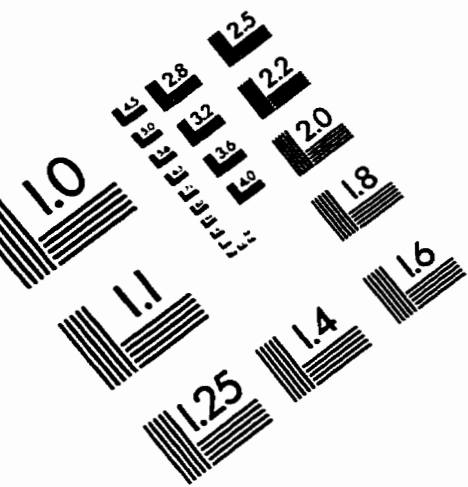

APPLIED IMAGE, Inc
1653 East Main Street
Rochester, NY 14609 USA
Phone: 716/482-0300
Fax: 716/288-5989

© 1993, Applied Image, Inc.. All Rights Reserved