

## **INFORMATION TO USERS**

**This manuscript has been reproduced from the microfilm master. UMI films the text directly from the original or copy submitted. Thus, some thesis and dissertation copies are in typewriter face, while others may be from any type of computer printer.**

**The quality of this reproduction is dependent upon the quality of the copy submitted. Broken or indistinct print, colored or poor quality illustrations and photographs, print bleedthrough, substandard margins, and improper alignment can adversely affect reproduction.**

**In the unlikely event that the author did not send UMI a complete manuscript and there are missing pages, these will be noted. Also, if unauthorized copyright material had to be removed, a note will indicate the deletion.**

**Oversize materials (e.g., maps, drawings, charts) are reproduced by sectioning the original, beginning at the upper left-hand corner and continuing from left to right in equal sections with small overlaps.**

**Photographs included in the original manuscript have been reproduced xerographically in this copy. Higher quality 6" x 9" black and white photographic prints are available for any photographs or illustrations appearing in this copy for an additional charge. Contact UMI directly to order.**

**ProQuest Information and Learning  
300 North Zeeb Road, Ann Arbor, MI 48106-1346 USA  
800-521-0600**

**UMI<sup>®</sup>**



**The Life and Works of Dimitri Dimakopoulos Architect  
(1929-1995)**

**Alain Marcoux**

**A Thesis  
in  
the Department  
of  
Art History**

**Presented in Partial Fulfilment of the Requirement  
for the Degree of Master of Arts in Art History at  
Concordia University  
Montreal, Quebec, Canada**

**May 2002**

**©Alain Marcoux, 2002**



**National Library  
of Canada**

**Acquisitions and  
Bibliographic Services**

**395 Wellington Street  
Ottawa ON K1A 0N4  
Canada**

**Bibliothèque nationale  
du Canada**

**Acquisitions et  
services bibliographiques**

**395, rue Wellington  
Ottawa ON K1A 0N4  
Canada**

*Your file Votre référence*

*Our file Notre référence*

**The author has granted a non-exclusive licence allowing the National Library of Canada to reproduce, loan, distribute or sell copies of this thesis in microform, paper or electronic formats.**

**The author retains ownership of the copyright in this thesis. Neither the thesis nor substantial extracts from it may be printed or otherwise reproduced without the author's permission.**

**L'auteur a accordé une licence non exclusive permettant à la Bibliothèque nationale du Canada de reproduire, prêter, distribuer ou vendre des copies de cette thèse sous la forme de microfiche/film, de reproduction sur papier ou sur format électronique.**

**L'auteur conserve la propriété du droit d'auteur qui protège cette thèse. Ni la thèse ni des extraits substantiels de celle-ci ne doivent être imprimés ou autrement reproduits sans son autorisation.**

0-612-68502-0

**Canada**



## ABSTRACT

### The Life and Works of Dimitri Dimakopoulos Architect (1929-1995)

Alain Marcoux

This art historical retrospective on an eminent Canadian architect of the twentieth century is not a biography. Since Dimitri Dimakopoulos was a very discrete and reserved person, the thesis is much more oriented towards his architectural works than his private life and intimate personality. Following a short introduction, the first part deals with his early life in Athens from 1929 to 1948 in relation with the major socio-political events of the period. It also includes a summary of his university studies at the McGill School of Architecture from 1948 to 1955, focusing on his academic activities in relation with the program of studies.

The second part of the thesis deals with his partnership from 1955 to 1969 in ARCOP, a major architectural firm operating in Montreal during that period. It investigates his participation or full involvement as an architectural designer in various projects of the firm. The third part of the thesis deals with the works produced by his own architectural firm called Dimitri Dimakopoulos & Partners between 1970 and 1995. Each major project of the firm is investigated in detail from architectural and art historical point of views. Finally, a conclusion elaborates upon the characteristics of Dimakopoulos' oeuvre, from an architectural design and stylistic point of view in relation with the period of his production.

## **Aknowledgements**

I would like to thank my thesis supervisor Dr. Jean Bélisle for his professional guidance and support in the preparation of this thesis, as well as during my undergraduate and graduate programs of studies in art history. I would also like to thank the surviving members of the Dimakopoulos family for providing precious information relating to the first part of the thesis and in particular Irene Dimakopoulos who provided support in answering three consecutive questionnaires on her father's life.

The second part of the thesis could not have been written without the contributions of Guy Desbarats, an eminent Canadian architect and former partner in ARCOP, who was a long time friend and close collaborator of Dimitri Dimakopoulos in their architectural co-partnership firm from 1955 to 1968. Similarly, I would like to thank David Wigglesworth, former associate and partner in the firm Dimitri Dimakopoulos & Partners from 1970 to 1995. Without his invaluable collaboration, the third part of this thesis could not have been written with such detailed information.

Finally, I would like to thank all the other participants mentioned in the thesis who contributed in the gathering of historical information on the subject. In particular, Hans Stenman, Eva Vecsei and Arthur Nichol, former collaborators and associates of Dimitri Dimakopoulos, provided important information on many architectural projects in which they were involved.

## Table of Contents

<b>List of Illustrations</b> .....	vi
<b>Introduction</b> .....	1
<b>Part One - Life in Athens and Studies at McGill (1929-1955)</b> .....	5
<u>Life in Athens</u> .....	5
<u>Studies at McGill</u> .....	8
<b>Part Two - Partnership in ARCOP (1955-1969)</b> .....	16
<u>Designer Associate</u> .....	16
<u>Partnership</u> .....	19
<b>Part Three - Dimitri Dimakopoulos &amp; Partners (1970-1995)</b> .....	61
<u>The Seventies</u> .....	61
<u>The Eighties and Nineties</u> .....	88
<b>Conclusion</b> .....	130
<b>Endnotes</b>	
Part One.....	139
Part Two.....	143
Part Three.....	161
Conclusion.....	209
<b>Illustrations</b> .....	212
<b>Bibliography</b> .....	313

## List of Illustrations

- Fig. 1. Dimitri at about 7 years old in Athens, c.1936.
- Fig. 2. Draughting during the McGill University Years (1949-55).
- Fig. 3. Sketching during the McGill University Years (1949-55).
- Fig. 4. Relaxing during the McGill University Years (1949-55).
- Fig. 5. Wedding at St.Peter and St.Paul Church, Montreal, June 5, 1955.
- Fig. 6. Wedding Reception in Montreal on June 5, 1955.
- Fig. 7. Graduating at McGill University on May 25, 1955.
- Fig. 8. Lydia and Dimitri at the McGill University Graduation.
- Fig. 9. Perspective. Vancouver Civic Auditorium Competition, 1955.
- Fig. 10. Site Plan. Vancouver Civic Auditorium Competition, 1955.
- Fig. 11. The 6 ADDLMS Architects of the Vancouver Civic Auditorium.
- Fig. 12. Revised Plans. Queen Elizabeth Theatre, Vancouver, 1955-60.
- Fig. 13. Opening of the Queen Elizabeth Theatre, Vancouver, July 1959.
- Fig. 14. Main Façade. Drummond Plaza Apartments, Montreal, 1957-8.
- Fig. 15. Second Version of the Place des Arts Masterplan, Montreal, 1958.
- Fig. 16. Three Versions of the Grande Salle, Place des Arts, Montreal.
- Fig. 17. Plans and Sections. Grande Salle, Place des Arts, Montreal.
- Fig. 18. Exterior Perspective. Grande Salle, Place des Arts, Montreal.
- Fig. 19. Exterior View. Grande Salle, Place des Arts, Montreal, 1958-63.
- Fig. 20. Grande Salle Opening Night Audience on September 21, 1963.
- Fig. 21. Affleck Desbarats Dimakopoulos Lebensold Sise in 1964.
- Fig. 22. St. George Greek Orthodox Cathedral, Montreal, 1958-62.
- Fig. 23. Plans and Interior Detail. St. George Greek Orthodox Cathedral.
- Fig. 24. Interior View. St. George Greek Orthodox Cathedral.

- Fig. 25. Exterior View. Norman Wade Building, Pointe-Claire, 1961-2.
- Fig. 26. Plan and Interior View. Norman Wade Building, Pointe-Claire.
- Fig. 27. Section and Plans. Summerlea Golf & Country Club, 1960-3.
- Fig. 28. Summerlea Golf & Country Club, Pointe Cascades, PQ, 1960-3.
- Fig. 29. 4 Site Plan Progressive Design Sketches. Fathers of Confederation Memorial Building Competition Project for Charlottetown, 1962.
- Fig. 30. Plan View. Fathers of Confederation Memorial Building Competition Project for Charlottetown, 1962.
- Fig. 31. Sections. Fathers of Confederation Memorial Building Competition Project for Charlottetown 1962.
- Fig. 32. Competition Model. Fathers of Confederation Memorial Building Competition Project for Charlottetown, P.E.I., 1962.
- Fig. 33. Prime Minister John Diefenbaker and Winning Architect Dimitri Dimakopoulos with Memorial Building Model, Ottawa, 1962.
- Fig. 34. View on the Theatre from the West. Fathers of Confederation Memorial Building, Charlottetown, P.E.I., 1962-4.
- Fig. 35. Stamp. First Day of Issue Commemorating the 100th Anniversary of the Charlottetown Conference, July 29, 1964.
- Fig. 36. Her Majesty, Queen Elizabeth II Inaugurating the Fathers of Confederation Memorial Building on October 6, 1964.
- Fig. 37. View from the South-East. Provincial Government Centre, Charlottetown, P.E.I., 1963-5.
- Fig. 38. South-East Corner Tower. Place Bonaventure, Montreal, 1963-7.
- Fig. 39. Site Plan and Model. Arts and Cultural Centre, St John's, 1964-7.
- Fig. 40. Dimakopoulos Residence, 461 Clarke Ave., Westmount, 1966-7.
- Fig. 41. Model. Osaka '70 Canadian Pavilion Competition Project, 1966-7.

- Fig. 42. Site Plan. Carlo Della Valle's Residence, Alassio, Italy, 1967-68.
- Fig. 43. View on Exterior Wall. Complexe Scientifique, Ste-Foy, 1968-9.
- Fig. 44. Collège Montis Regii Project, Université de Montréal, 1969.
- Fig. 45. Model. Cité Concordia Project, Montreal, 1969-73.
- Fig. 46. Model. Concordia West Block Project, Montreal, 1969-73.
- Fig. 47. Exterior Perspective. Loews Le Concorde, Quebec City, 1969-74.
- Fig. 48. View from Place Montcalm. Loews Le Concorde, Quebec City.
- Fig. 49. Interior Public Space. Elev. 200. Site Plan. East Pole, Hull, c.1974.
- Fig. 50. Early Model. East Pole. Downtown Hull, c.1972.
- Fig. 51. Late Model. Place d'Accueil and Place du Portage III, Hull, 1973.
- Fig. 52. Place du Portage III and Place du Centre, Hull, 1977.
- Fig. 53. Interior Perspective of Atrium. UQAM Phase I, Montreal, 1971-9.
- Fig. 54. Late Model. UQAM Phase I, Montreal, c.1975.
- Fig. 55. Brickwork. UQAM Phase I, Montreal, 1971-9.
- Fig. 56. Final Model. Winter Wondorlando Project, Orlando, Fla., 1974.
- Fig. 57. Saint Jean Street Elevation. 244 St. James Street West Renovation/  
Expansion Project (London & Lancashire Bldg.), Montreal, 1975.
- Fig. 58. Site Plan. Palais des Congrès, Montreal. Competition Project, 1978.
- Fig. 59. Dimitri Dimakopoulos & Partners.
- Fig. 60. Perspective. Palais de Justice de Québec Competition Project, 1979.
- Fig. 61. Site Plan. Palais de Justice de Québec Competition Project, 1979.
- Fig. 62. Dimitri with Model of Palais de Justice de Québec, August 1979.
- Fig. 63. Main Façades. Palais de Justice de Québec, 1979-83.
- Fig. 64. Interior View on Atrium. Palais de Justice de Québec, 1979-83.
- Fig. 65. Interior View on Freiman Mall, Ottawa, 1979-82.
- Fig. 66. Final Model. Taikoo Shing Site "B" Project, Hong Kong, 1980-1.

- Fig. 67. Elevation. Tour Boumediene Competition Project, Algiers, 1980.
- Fig. 68. Final Model. Edifice La Laurentienne, Montreal, 1980-6.
- Fig. 69. Perspective. Entrance. Edifice La Laurentienne, Montreal, 1980-6.
- Fig. 70. Lateral View. Edifice La Laurentienne, Montreal, 1980-6.
- Fig. 71. Aerial View. Dawson College Atwater Campus, Montreal, 1982-8.
- Fig. 72. Front Façade of Dawson College Library, Montreal, 1982-8.
- Fig. 73. Interior View of Dawson College Library, Montreal, 1982-8.
- Fig. 74. Model. National Museum of Man Competition Project, Hull, 1982.
- Fig. 75. Model. Yamani Residence, Manama, Bâhrein, 1983-4.
- Fig. 76. Late Model. No. 2 Place Alexis Nihon, Montreal, 1983-6.
- Fig. 77. Exterior Perspective. No. 1 Place Alexis Nihon, Montreal, 1986-7.
- Fig. 78. Model. Bio-Technology Research Institute, Montreal, 1983-7.
- Fig. 79. Exterior View. Bio-Technology Research Institute, Montreal.
- Fig. 80. Aerial View. Bio-Mega Laboratories, Laval, 1984-5.
- Fig. 81. Interior View of Atrium. Bio-Mega Laboratories, Laval, 1984-5.
- Fig. 82. Interior and Exterior Perspectives. Musée d'Art Contemporain de Montréal Competition Project, 1984.
- Fig. 83. Site Plan. Jing An Int'l Hilton Hotel, Shanghai, 1984.
- Fig. 84. Exterior Perspective. Jing An Int'l Hilton Hotel, Shanghai, 1984.
- Fig. 85. Place Pasteur Perspective. UQAM Phase II, Montreal, 1985-92.
- Fig. 86. Ste.Catherine St. Perspective. UQAM Phase II, Montreal, 1985-92.
- Fig. 87. Dorchester Blvd. Perspective. UQAM Phase II, Montreal, 1985-92.
- Fig. 88. Interior View of Rehearsal Room. Salle Wilfrid Pelletier Expansion, Place des Arts, Montreal, 1987-92
- Fig. 89. Exterior View of Addition. Salle Wilfrid Pelletier Expansion, Place des Arts, Montreal, 1987-92

- Fig. 90. Aerial Perspective of the Completed Atwater Campus. Dawson College Phase III, Montreal, 1988-90.
- Fig. 91. Exterior View of the Phase III Wing. Dawson College Phase III, Montreal, 1988-90.
- Fig. 92. Upper Shaft and Crown. Le 1000 de La Gauchetière, Montreal.
- Fig. 93. Interior Perspective. Bell Amphitheatre Skating Rink. Le 1000 de La Gauchetière, Montreal, 1988-92.
- Fig. 94. Dorchester Square View. Le 1000 de La Gauchetière, Montreal.
- Fig. 95. Dimitri Dimakopoulos in the Bell Amphitheatre. Le 1000 de La Gauchetière, Montreal, 1992.
- Fig. 96. Site Plan. Place des Arts Quadrilateral Competition Project, 1988.
- Fig. 97. Final Model. Place des Arts Quadrilateral, Montreal, 1988-93.
- Fig. 98. Exterior View on Monumental Stairs. Place des Arts Quadrilateral, Montreal, 1988-93.
- Fig. 99. Exterior View on Swimming Pool Pavilion. Apache Residence Expansion, Dorval, 1989-93.
- Fig. 100. Model. Hotel Complex Project, Mala Strana, Prague, 1990-91.



## INTRODUCTION

The object of this thesis is to produce the first complete written account of the life and works of Dimitri Dimakopoulos (1929-95), a notable Canadian architect who practised his profession in Montreal, Province of Quebec, from 1955 to 1995. Having known him as an architectural student and employee in the summer of 1972, and followed the development of his career as a colleague afterwards, it became very interesting for me to undertake this retrospective.

During his career, Dimakopoulos designed a series of outstanding buildings in Quebec, Canada and overseas, often realized in collaboration with other architects or architectural firms. His highly productive career as an architectural designer, which has not previously been evaluated, warrants a monographic consideration.

Specifically, the first part of the thesis deals with his life in Athens from 1929 to 1948, followed by his architectural studies at the McGill University School of Architecture, from 1949 to 1955. A brief but pertinent analysis of these subjects was necessary to depict adequately and completely a portrait of the character.

It includes information gathered from his surviving family and relatives on his youth in Greece in a small family belonging to the High Greek Bourgeoisie. It also points out the main events which took place during his university studies, especially the winning in 1955 of his first architectural competition for the Queen Elizabeth Theatre in Vancouver which became the turning point of his later life and career in Canada.

The second part of this thesis concerns his partnership in the firm

Affleck Desbarats Dimakopoulos Lebensold Michaud Sise Architects (ARCOP), from 1955 to 1969, the leading Canadian architectural firm of the 1960's. Responsible for the architectural design and implementation of some major Canadian Modernist landmarks such as the Queen Elizabeth Theatre in Vancouver, the National Arts Centre in Ottawa, the Fathers of Confederation Commemorative Buildings in Charlottetown, the Place des Arts, Place Ville-Marie and Place Bonaventure in Montreal as well as various pavilions for Expo' 67 and buildings on the McGill University campus, the ARCOP firm became the largest of its kind in Canada, headed by a handful of talented architects working altogether and among whom Dimitri was reputed to be one of the most gifted designers.

Dimakopoulos' personal involvement in the design of these projects as well as other solo projects and buildings of the period such as the Greek Orthodox Cathedral in Montreal and the Dimakopoulos Residence in Westmount are investigated in detail. In a complementary manner, main events and other pertinent aspects of his working and private life during this intermediary period are also highlighted.

Dealing with the last period of Dimakopoulos' life which took place after 1970, the third part of the thesis focuses on the major architectural projects and buildings of his independent firm, Dimitri Dimakopoulos and Partners, which he founded immediately after his departure from ARCOP.

Architectural landmarks such as the Place du Portage III in Hull, the Université du Québec Buildings, La Laurentienne Building and Le 1000 de La Gauchetière Tower in Montreal, Le Concorde Hotel and the new Palais de Justice in Québec City are all investigated in detail.

Other projects and buildings in Canada, Greece, Italy, Saudi Arabia,

United States, Algeria, Hong Kong, Bahrain and China are also presented. Demonstrating his remarkable talent as an architect, builder, designer, draughtsman and visual artist obtaining major commissions through numerous national and international competitions, prizes and awards of excellence, this third part of the thesis also establishes a full body of information on the architect's later works, complemented by pertinent data on his associates, employees and relations with whom he shared his hard-working life.

Situating Dimitri Dimakopoulos among the most important Canadian architects of the period, such as Arthur Erickson (b.1924), Eberhard Zeidler (b.1926), Raymond Moriyama (b.1929), Douglas Cardinal (b.1934) and Moshe Safdie (b.1938), the thesis distinguishes his personal style from the common contemporary trends.

It demonstrates a relatively slow and conservative evolution similar to that of Arthur Erickson, from an early High-Modernist approach to a Late-Modernist standpoint, followed by a Late Post-Modernist and contextualist orientation. Like Eero Saarinen (1910-61) and Philip Johnson (b.1906), Dimitri Dimakopoulos worked in various styles, initiating different architectonic concepts from one project to another.

He investigated, through a geometrically oriented Formalist approach, the interplay of complex volumetric assemblies and details, of masses and voids, of light and shade, of contrasting colors and textures. His architecture occasionally related to that of Mies van der Rohe (1886-1969) and Philip Johnson, Eero Saarinen and Louis Kahn (1901-74), Arata Isozaki (b.1931) and Michael Graves (b.1934). His works demonstrated an artistic balance between self-expression, what was acceptable to public taste in Canada,

**and international avant-garde development, regulated by the constraints of a limited and competitive local market for large commissions from the public and private sectors.**

**Finally, the thesis' conclusion summarizes his place in World and Canadian art history through his main architectural works across Canada and abroad. It also stresses his character as an artistically oriented architect, an intelligent and respected business man, an appreciated family man and friend, a warm and expressive human being.**

## PART ONE - LIFE IN ATHENS AND STUDIES AT MCGILL (1929-55)

Dimitri Dimakopoulos was born a healthy boy in an hospital of Athens, Greece, on September 14, 1929<sup>[1]</sup>. The only son of Georges Dimakopoulos (1891-1982) and Fotini Klara (1904-1984), married since 1925, the infant was raised in a good Greek Orthodox bourgeois family<sup>[2]</sup>. They lived in the elegant and very closed residential quarter of Kolonaki, situated in downtown Athens between Mount Lycabette and the Acropolis, the National Gardens and the nineteenth century monumental ensemble of the University, the Academia and the National Library. Located at 5 Haritos Street, their dwelling-place was a very comfortable apartment suite located on the main floor of a five-storey building with elevator situated near Constitutional Square or Place Syndagma, in an area mostly reserved for ministries, embassies and museums<sup>[3]</sup>. Trained in Paris in the banking business, George Dimakopoulos, originally appointed in 1909 at the National Bank of Greece in Patras, was eventually transferred to the Athens central office in 1924 where he pursued a career as one of its directors until his 1952 retirement<sup>[4]</sup>.

Going through the political chaos of seven successive insurrections and military putsches which took place from 1922 to 1936, George witnessed the major reforms of Republican Greece (1924-36) which included a more stable government period between 1928 and 32 under Eleftherios Venizelos (1864-1936). Large construction works, aid to refugees, Macedonian land drainage, stabilization of the drachma and creation of the Bank of Greece in 1927 were the most outstanding achievements of the period <sup>[5]</sup>. Although important, they were insufficient to control increasing unemployment and workers' strikes, the Cypriot problem being at the origin of

Venizelos' resignation. Following a short military interlude and a plebiscite in favor of the Restoration, King George II (1890-1947) returned to his throne in 1935 after an absence of twelve years, covering in 1936 the military putsch of General Ioannis Metaxas (1871-1941), abolishing the Constitution, dissolving the Chamber for ten years and setting up a military dictatorship against the Communist revolutionaries<sup>[6]</sup>.

During this period, Dimitri was educated in a prominent family of the Greek community, his father being a very distinguished character, highly academic and knowledgeable in philosophy. At six years of age, he started attending primary school, at the nearby Maraslion School (fig. 1)<sup>[7]</sup>. Always a good and studious pupil, he enjoyed learning about all topics and liked reading the encyclopedia. Because of the revolutionaries, streets were not safe, forcing him to play indoors, occasionally with friends. Demonstrating early his intellectual and artistic inclinations, he enjoyed drawing, fabricating sculptural objects in paper and cardboard and constructing model boats and airplanes from kits.

In September 1939, Metaxas was proclaiming the neutrality of Greece between the dictatorships of the Axis and the European democracies. After one year, he was forced to declare war against the Italian invaders, the Greek resistance winning temporarily until the German occupation of May 1941. Following capitulation, King George II left for England in exile while the Greek Government was fleeing to Egypt. From September 1941 onwards, the Greek resistance was organized by the Communist revolutionaries who recruited all Greek Patriots to drive out the German, Italian and Bulgarian invaders. The resistance becoming effective through manifestations, strikes, sabotages and guerilla operations, the National Liberation

Front was joining the union of Greek forces in 1942, associating with a national unity government in exile directed by the democrat Gheorghios Papandhreu (1888-1968). Placed under the command of the British army, the Communist armed forces were contributing to the evacuation of Athens by the Germans in October 1944. Soon afterwards, political struggle was at the origin of violent armed fights in Athens, forcing the Greek Government to ask for more British help. After six months of bloody street fights, the revolutionary army was finally disarmed in February 1945. The Royalist victory at the 1946 elections was at the origin of the return of King George II in Athens, followed by severe epurations against the Left Extremists. Desolated by death and destruction, Greece was receiving in 1947 major financial and military help from the Americans to reconstruct the country<sup>[8]</sup>.

During that tumultuous period, Dimitri was confined at home, attending High School whenever it was possible. Like his peers in other wealthy, prominent and educated Greek families, he was educated from age eleven or twelve by a French Governess. Learning from her an impeccable spoken and written French, he spoke fluently Greek and English with his parents as well<sup>[9]</sup>. Uninvolved in sports and outdoor activities, Dimitri spent most of his teenage years at home or at school, mostly involved in intellectual and artistic activities, under cover of the war raging outdoors, with no light sometimes due to electrical failures.

Graduating from the Experimental School of the University of Athens in 1947, Dimitri met Major-General Léo R. Laflèche, appointed Canadian Ambassador to Greece from 1945 to 1949 and a friend of his father, who convinced him to register at McGill University School of Architecture <sup>[10]</sup>. Interested in the Architecture and Medicine programs, he was accepted

in both disciplines, deciding finally on Architecture. He arrived in Quebec in 1948 and pursued his architectural studies until his graduation in the spring of 1955. During that period, the course for a degree in Architecture at McGill was for six years, combining architectural and engineering studies including planning, structural and mechanical design. The first two years were regular years in the Faculty of Engineering, except for an alternative course in drawing in the second year. Each of the third, fourth and fifth years featured more than a dozen courses, half of which dealt with engineering subjects. The work of the last year was largely architectural design and studies in professional practice<sup>[11]</sup>.

During that period, John Bland (b.1911), who was the director of the School from 1945 to 1967, taught architectural design, history and report. He was assisted by Professor Harold Spence-Sales (b.1908), a town-planner who taught planning and design, and Assistant Professor A. Stuart Wilson, (1912-91) concerned with design and construction<sup>[12]</sup>. Varying from five to eight, Sessional Lecturers included J.Watson Balharrie (1910-67) teaching construction, specifications and design, as well as the well known artists Arthur Lismer (1885-1969) and Gordon Webber (1909-65) teaching design theory, art history and free-hand drawing, as well as design, drawing and sketching. From 1950 onwards, the remaining regular staff included the architects Hazen Sise (1906-74) and Frederick Lebensold (1917-85) who taught respectively history and report, as well as design and construction<sup>[13]</sup>.

Due to the influx of young Canadian and American war veterans in Engineering at McGill, the first year of the program was given at Dawson College, located at that time in the former Royal Canadian Air Force military installations of Saint-Jean-sur-le-Richelieu, south-east of Montreal.



Dimitri started there, working hard and studying most of the time, socializing on occasions. Even then, he had a passion for architecture and drew very well<sup>[14]</sup>. The second year of the program was given at the Mc Connell Engineering Building situated on the McGill campus. Excellent in the Architectural Drawing and Elements of Design course taught by John Bland and Gordon Webber, Dimitri followed all the remaining programs featuring standard engineering classes<sup>[15]</sup>. Strong in engineering, Dimitri, who had rented a small apartment in Westmount, fell sick with tuberculosis in the course of 1950 and had to go back to Athens for one year<sup>[16]</sup>.

On his return to Montreal, he rented another apartment in Westmount, pursuing his architectural studies at the McGill School of Architecture located by then in a building now demolished situated on the west corner of University and Milton Streets. Attached to a bookstore, it occupied half of a semi-detached four-storey Victorian house with basement<sup>[17]</sup>. During the third year of the architectural program, in 1951-52, Dimitri was initiated to the Elements of Design by Gordon Webber, experimenting with colours and textures for the rendering of planes in space, designing three-dimensional tactile structures and developing visual aids for the presentation of architectural projects<sup>[18]</sup>.

Benefiting from a former education oriented towards the visual arts, Dimitri displayed immediately advanced skills in drawing exceeding all his colleagues, and was already considered an outstanding designer and draughtsman. Very personal and introverted, he could be busy sixteen hours per day, living only for architecture. Attending evening drawing courses at the Art Association, in the Montreal Museum of Fine Arts, he painted in many media, spending a lot of time in the research of forms and tectonic

results for his architectural solo projects.

Socializing with a few Greek and Canadian friends in architecture and engineering, Dimitri met his future wife Lydia d. Dimitri Chabaline (1930-1995) at a YMCA Saturday night dance held for university students. Born in Tiensin, China, this Russian Orthodox girl was raised in Russia, emigrating at eight years of age to France, growing up in Salies-de-Béarn, in the southwest.

She lived temporarily in Florence, Italy, before emigrating to Quebec in 1952 with a French Baccalauréat<sup>[19]</sup>. She was introduced to him by her sister Nadia who was a good friend and they were always seen together afterwards. Very supportive during his studies, she had to go through many difficulties. Although very studious and brilliant, Dimitri was always anxious at taking exams and had almost to be pushed in the examination rooms, succeeding nevertheless with high marks. They experienced together a very close relationship before getting married two years later.

In 1952-53, Watson Balharrie and Maxwell C. Baker taught Dimitri Design, Class A, in which detailed studies of two or three residential, industrial or educational buildings were made at each session. Students had to produce program outlines reports, preliminary plans, sections and elevations, structural layouts, partial working drawings, final presentation drawings and scaled models<sup>[20]</sup>. Preferring to be called by his diminutive, “Dimi” spent a lot of time at his drafting table, working in jacket, white shirt and tie, late at night, drawing with T-bar and set squares (fig. 2).

During that period, he produced a very large scale colored plan drawing of a Miesian house with garden court painted on the wall backing the secretaries’ desks<sup>[21]</sup>. In the fourth year, internationally renowned architects

such as Philip Johnson (b.1906), Bruce Goff (1904-82) and Gio Ponti (1891-1979) visited McGill for conferences on Modern design.

In late September 1953, Dimitri participated in a ten-day sketching school supervised by Gordon Webber and A. Stuart Wilson. Held at Lachenaie and Laprairie, students stayed there overnight, renting motel rooms or similar accommodations. The next year another one was held in Kingston, Ontario. Examining and making graphic records of unfamiliar districts, Dimitri displayed great looseness and naturalism in his works<sup>[22]</sup>. One of the best sketchers of his group, he produced drawings in pencil, pen and ink and colours with flare, ability, skill and ease (fig. 3, 4).

In 1953-54, Fred Lebensold taught him Design, Class B, a 16 hour per week workshop in which the students had to design recreation, transportation and hospital buildings<sup>[23]</sup>. One of these projects was a restaurant-stop on an highway. Already a skilled draughtsman, Dimitri soon demonstrated his outstanding talent, acknowledged by Lebensold who became his chief teacher. Lebensold was always very brief and severe at the student projects reviews, but generally adopted a praising attitude to Dimitri's architectural works.

Born in Warsaw, Poland, naturalized British and graduated from the Polytechnical School of London in 1939, Lebensold arrived in Montreal from England like Spence-Sales before him. Struggling for work, he registered at the Province of Quebec Association of Architects in 1949, and started teaching at McGill in 1950, working initially full-time in his school office.

Dimitri soon sympathized with Lebensold, who later offered him an architectural drafting summer job starting in May 1954 in his Sherbrooke

Street office, producing working drawings with a few other students<sup>[24]</sup>. Not too involved in school social activities, spending minimum presence in regular classes, he studied a lot at home, working hard most of the time on his projects and finishing late at night.

Without the knowledge of his parents, Dimitri's wedding with Lydia took place on June 5, 1954 at Saint Peter and Saint Paul Russo-Greek Orthodox Church, in Montreal (fig. 5,6)<sup>[25]</sup>. Since Lydia's father was deceased, only her mother, Irene Chabaline, attended with a few friends at a small wedding followed by a party. After a brief stay in the Laurentians for their honeymoon trip, the Dimakopoulos moved into a small dwelling located at 4360 Décarie Boulevard, followed one year later by a lovely 4½-room apartment at 5470 Bessboro Avenue, in Montreal.

During his last school year, in 1954-55, Dimitri took Design, Class C, a 21 to 24 hours per week workshop taught by Bland and Spence-Sales. It involved the design of a complex or group of buildings, including housing, commercial and public facilities. The diploma design for graduation was done in the second term. Selected by each student, the subject had to be approved before January 3rd 1955, the final presentation including a written report and preliminary drawings<sup>[26]</sup>.

Working often outside of school, at home and in Fred Lebensold's office, Dimitri attended his courses and examinations, always respecting project deadlines. For his diploma thesis, Dimitri, who had initially selected a concert hall project for Montreal, developed from January 1955 a sophisticated design derived from Mies van der Rohe and Philip Johnson. All conceived by Dimitri under his teacher's supervision, it answered all the requirements of the Vancouver Civic Auditorium National Competition

program, previously entered by Lebensold in the latter part of 1954<sup>[27]</sup>.

It would eventually form the basis of the revised winning scheme entry, conceived, detailed and finalized in architectural co-partnership with Lebensold, Affleck, Desbarats, Michaud and Sise. Dimitri's design was highly praised by the McGill teachers, much concerned with Functionalist and Structuralist architecture and admiring mostly the works of Mies van der Rohe (1886-1969) and Pier Luigi Nervi (1891-1979).

Displaying a simple and highly formal approach and expressing the concept of an auditorium form suspended in a glass cage, Dimitri's architectural scheme featured a Miesian-like transparent box exterior shell, with two opaque rectangular volumes protruding above the flat roof, one being higher than the other<sup>[28]</sup>.

Facing a spacious square front court sided by an independent low rectangular annexed restaurant setting back the auditorium, the front façade displayed excellent proportions and was exquisitely detailed. The main building, which featured a symmetrical internal arrangement, included a main hall to seat 2750-3000 people and a secondary one to seat 470-500. Conceived as an active centre within the downtown Vancouver townscape, it offered urban, civic, lively and intimate qualities with its two large meeting rooms, various foyers, specialty shops, restaurant, cocktail lounge, fountains, lawns and large paved areas<sup>[29]</sup>.

Dimitri's original presentation drawings were made in pencil on ten yellow onion sketch sheets of 20" x 36". They featured a site plan at smaller scale and six floor plans displaying the lower and upper garage levels, the plaza, upper orchestra, balcony, upper balcony and roof levels, complemented by two sheets of elevations and one small theatre section,

all at 1/16"=1'-0" scale<sup>[30]</sup>.

Dimitri's project was used for two purposes: for his graduation project and as the basis of the project to be submitted for the competition. His project was displayed at the School of Architecture with the other graduating students' projects. A jury composed of teachers and architects reviewed the projects in the absence of the students. Dimitri obtained his Bachelor degree in Architecture on May 25, 1955, although he did not receive either of the two available major awards. He was present at the McGill University Annual Convocation held on the main lawn of the campus, wearing a black gown and hood as he received his diploma from the Chancellor Bertie Charles Gardner, along with fourteen other architectural candidates (fig. 7,8).

It was said at the time that he had helped some Greek friends through their examinations while he was considering returning to Greece to practice his profession. Winning his first competition just two months after he had graduated, "it was sudden fame overnight"<sup>[31]</sup>. He decided to stay in Montreal.

As soon as May 1954, the Vancouver City Council had decided to organize an open, national competition for a Civic Auditorium with Swiss-born Professor Frederic Lasserre (1911-61), Sutton Brown and Eero Saarinen (1910-61) as chosen assessors<sup>[32]</sup>. A total of \$10,000 was set aside for prizes, first place being worth half the money and the building commission. The competition, organized to select an architect rather than a design, attracted 64 entries. It was officially won in July 1955 by the architects D. F. Lebensold, Guy Desbarats, R. T. Affleck, Jean Michaud and Hazen Sise, of Montreal: D. Dimakopoulos was only mentioned as a

a complementary “designer associate” since he was not yet a registered architect<sup>[33]</sup>. The second prize worth \$2500 was given to Clayton and Bond, and the third one of \$1000 to Jules P. Paivo, both of Calgary<sup>[34]</sup>.

Meanwhile, at the McGill School of Architecture, Dimitri’s project was contested by the other students who complained of injustice. They requested the resignation of Fred Lebensold who was accused of biased attitude, being unable to distinguish between office team work and a student university project<sup>[35]</sup>. John Bland was upset by Dimitri’s participation in the competition and nearly disqualified him from his degree credits. Fortunately, he did not act on the matter.

During the course of his studies, Dimitri had been very meticulous and perfectionist, demonstrating his exceptional talent as an architectural problem solver sensitive to the environment surrounding his buildings. In the art of Architecture, he had been supreme, extremely talented in design and drafting, sketching and perspective making. He had become equally well prepared in the technical and structural, administrative and legal aspects of his future profession.

## PART TWO - PARTNERSHIP IN ARCOP (1955-1969)

In 1953, Jean Michaud (1919-95), who had obtained the commission for the new Town of Mount Royal Federal Post Office, asked his 1945 McGill graduate colleague Ray Affleck (1922-89) to join him on the project<sup>[1]</sup>. Following previous discussions on a loose co-partnership, Affleck soon contacted Guy Desbarats (b.1925), a 1948 McGill graduate, to join them and work on the project<sup>[2]</sup>. This was the opportunity for them to rent office space in a pleasant residential basement with fireplace and facilities located at 4350 Sherbrooke West, in Westmount. Desbarats and Affleck entered many competitions including the new Ottawa Police Headquarters, 1954-55, for which they obtained a third place award<sup>[3]</sup>. Desbarats won the Home '53 Chatelaine Magazine Competition in co-partnership with Fred Lebensold who had his office at 3201 Forrest Hill at the time<sup>[4]</sup>. While Lebensold was moving to 4465 Sherbrooke W. nearby in early 1955, Hazen Sise, was obtaining the Mount Royal Beaver Lake Pavilion commission, contacting Desbarats to join him as partner on the project which would later be completed in 1956<sup>[5]</sup>.

Meanwhile, Dimitri, who had been working on his graduation project at Lebensold's office since January 1955, agreed with all of them to use it as a starting point for their final competition entry. While Lebensold was re-registering under a new group name, the partners made further research in books and magazines on precedents, developing further the acoustics, seating, sight lines, backstage, lobbies, etc. Dimitri's original project was completely redone at their 4350 Sherbrooke address<sup>[6]</sup>. Excellent team work developed for the detailed planning. While Sise and Michaud contributed comments in very good discussions on circulation logic, site relationships



and city planning, the four other design partners were involved in actual drawings. The plans, elevations and sections were altered in many ways and a completely new set of drawings was produced in at least one month. While Desbarats and Dimitri produced the final perspectives and façade drawings, Affleck and Lebensold produced the plans (fig. 9,10)<sup>[7]</sup>. The notably more complex project was finally sent by train to Vancouver five hours before the deadline. The final submission displayed a quiet monumentality derived from Scandinavian sources, mainly the Swedish Opera House and Concert Hall in Malmö<sup>[8]</sup>. It offered in its symmetrical, simple Modernist composition some truly Miesian characteristics, especially in the boxy glazed enclosure detailed with much subtlety and elegance. Similarly to other contemporary landmarks designed by Johnson and Saarinen, the proposed building departed from straightforward Miesian Functionalism with its loose roof volumetry and angular corner treatment, its assymetrical front court piazza and some fancy textured surface ornamentation<sup>[9]</sup>.

Although the jury considered the winning scheme to be extremely sensitive, it contained however some minor defects such as the use of extensive areas of glass facing the massive adjacent Post Office. The site plan and general massing were judged very well integrated in height and scale to the immediate urban context, while the front court laid out in an European manner and sided by a low restaurant annex offered high urban quality to the new Vancouver Civic Centre. The concept of the auditorium form seeming suspended in a glass cage was highly appreciated similarly to the main court façade displaying excellent proportions and choice of materials<sup>[10]</sup>.

For the architects, the winning scheme was intended to create a strong unitary building following closely the skillfully established program. Their

simple and highly formal “parti”, with two theatres as principal masses, main and secondary, placed back to back in a transparent exterior shell, offered a pleasant unifying quality. The centrally located auditorium, entirely enclosed and inward-looking, was surrounded on all sides by glazed circulation areas looking out onto the piazza and city surroundings. Offering spatial delight and dynamic excitement, the various levels of the foyer floors also featured spectacular night views toward the piazza, outdoor landscaping and urban surroundings<sup>[11]</sup>. Classical and Modern in essence, the scheme offered a civic building timeless quality as well as a theatrical visual excitement and spatial experience.

Winning the first prize against sixty three competitors, the firm of D.F. Lebensold, Guy Desbarats, R.T. Affleck, Jean Michaud and Hazen Sise soon became established in Canada as a leading architectural group (fig. 11). As agreed between partners, “The Architects in Co-Partnership” (ARCOP) was formed with equal partners including Dimitri and the official name of the firm was modified to follow an alphabetical listing of registered architects names<sup>[12]</sup>. Adopting the kind of practice set up in Cambridge by Walter Gropius (1883-1969) and known as “The Architect’s Collaborative”, they remained ambiguous for a while as to who was in charge of what in the office, conducting eventually to the exasperation of the client<sup>[13]</sup>. By July 1955, the group had moved to their new office at 5060 Western Avenue, and the results of the competition were soon published in the August 1955 issue of the Architecture-Bâtiment-Construction magazine <sup>[14]</sup>. The same year, Dimitri obtained three architectural prizes for his project: “Anglin-Norcross”, “Construction” and “Concours Hobbs Glass”<sup>[15]</sup>.

Following his graduation, Dimitri still had eighteen months of architec-

tural apprenticeship to fulfil before becoming eligible for the admission examination of the Province of Quebec Association of Architects (PQAA). According to the McGill school program requirements, he had already completed six months of apprenticeship with the work previously done for Fred Lebensold since May 1954<sup>[16]</sup>. After the results of the competition, he was initially proposed financial compensation against which he would not be involved in the firm's development of the Vancouver's Civic Auditorium project. While Lebensold was hiring a lawyer to work out an arrangement, Dimitri, who was nervous and a bit suspicious, rejected the proposal and accepted instead a temporary status of "designer associate", involving equal partnership in all respects on the project<sup>[17]</sup>.

Dimitri officially pursued his apprenticeship under Fred Lebensold's tutorship until the November 19, 1956, the date of his PQAA examination. He was informed of the result on December 3rd, 1956, and, by March 4th, 1957, a PQAA resolution was passed allowing him to become a fully registered architect in the Province of Quebec<sup>[18]</sup>. It was only after that date that the name of the firm was changed to Affleck Desbarats Dimakopoulos Lebensold Michaud Sise Architects (ADDLMS).

During the period between August 1955 and May 1956, the group reviewed its original design to suit the budget. They preserved their simple and highly formal "parti" featuring two juxtaposed theatres in a transparent external shell, but modified the internal symmetrical arrangement of the two theatres, turning the smaller hall at right angles (fig. 12)<sup>[19]</sup>. Dimitri was involved in the design development throughout, as were Lebensold, Desbarats and Affleck. No Partner-in-charge was ever officially named on the project and they all eventually carried out other projects simultaneously. By

the time the commission was brought further into the second stage, featuring the contract documentation, competent staff had been hired to pursue the project development<sup>[20]</sup>. While Affleck studied some exterior details before working on other projects, Lebensold and Desbarats became deeply involved in the design development, working drawings and detailing, the latter supervising the interior finishes and details. As for Dimitri, he became involved in general design supervision and review of the working drawings. Seating and acoustics became areas of intense study and American consultants were hired on the project<sup>[21]</sup>.

The closer the contract documentation came to tender time, the more Lebensold took the lead of the project as the Partner-in-Charge. Taking over client visits and approvals in Vancouver, he became responsible for the general supervision and client relations. Dimitri was only peripherally involved in the construction, with Lebensold being seconded by Arthur B. Nichol (b.1923) who became the construction site supervisor in residence from 1958 until the fall of 1960<sup>[22]</sup>.

The whole Vancouver project was carried out in two contractual phases, the first being the main auditorium and the second the smaller theatre for which construction period spanned from 1960 to 1962<sup>[23]</sup>. Renamed for the occasion the Queen Elizabeth Theatre, the building was formally opened in July 1959 for the Second Vancouver International Festival (fig. 13).

At the grand opening during which the architects were well represented, the Austrian conductor Herbert von Karajan (1908-89) who was conducting the Vancouver Symphony Orchestra, declared: "I wish I could put it into my pocket and take it back to Berlin"<sup>[24]</sup>. In the October 1959 issue of The Canadian Architect, the new landmark was identified by a jury of twenty

leading Canadian architects as one of “the eleven best buildings since the war”.By 1962, the overall complex had cost \$11.5 million including fees<sup>[25]</sup>.

From mid-1956 and for at least six months, Dimitri, as an equal partner in the firm, worked solo and part-time on the design of the eleven-storey luxury apartment block tower located at 3435 Drummond Avenue, Montreal<sup>[26]</sup>. This design-built project in which the client was doing the construction without tenders was managed by K. Couropoulos, owner and contractor<sup>[27]</sup>. Dimitri made the design of an elegant building featuring a chamois brick veneer complemented by some polished grey granite<sup>[28]</sup>. It displayed one row of short concrete cantivered balconies with convex blind fronts. Spanning beside with alternate rythm, more elongated balconies offered opaque concrete and opened metal fronts, one above the other. At the top, a roof terrace featured an opened shelter on posts with concave concrete roof slab visible from the street below. Supervising the preliminary drawings and presenting them to the client, Dimitri worked in collaboration with Roland Dumais (1910-82), a French Canadian architect registered at the PQAA, under whose name the work was produced. The Drummond Plaza Apartments construction was completed in 1957 (fig. 14)<sup>[29]</sup>.

In the spring of 1956, Dimitri and Lydia moved from their first apartment on Décarie Boulevard to a “4½-room lovely apartment” located at 5470 Bessboro Avenue, Hamstead, Montreal<sup>[30]</sup>. This was to accomodate their future family. By the month of November, Lydia became pregnant, and on August 9, 1957, she gave birth to their first child at the Royal Victoria Hospital in Montreal<sup>[31]</sup>. Named Irene after the most famous Patron Saint of Greece, the baby girl was healthy and the mother quickly recovered<sup>[32]</sup>. After one week at the hospital, Lydia and Irene returned home and the maternal

grand-mother Irene Chabaline provided much assistance.

Until 1958, Dimitri spent most of his office time on the design development of the Queen Elizabeth Theatre and the Drummond Plaza<sup>[33]</sup>. In March 1958, the ARCOP's office moved from 5060 Western Avenue to the Dominion Square Building located at 1010 Sainte-Catherine West in downtown Montreal<sup>[34]</sup>. At the same time came the "bombshell - Place Ville Marie", followed by the Place des Arts commission in June 1958<sup>[35]</sup>. The Saint-George Greek Orthodox Cathedral commission was also awarded in mid-1958, a solo project which took most of Dimitri's time<sup>[36]</sup>.

It became a very busy period for Dimitri and ADDLMS; small and large commissions were entering in the office one after the other, being distributed amongst the various partners. The selection of the Partner-in-Charge for each project became a difficult task while tension between partners was growing rapidly within the firm<sup>[37]</sup>.

Innovative working techniques were developed for partners group design sessions such as patterns of group analysis and simulations. Emphasis was put on clear understanding of clients views, especially for competition programs and juries. Each partner would develop various design schemes individually. Group analysis, critics and comments would follow, leading to the final design decisions<sup>[38]</sup>. No name would ever be attached to the design product, being the result of a teamwork effort. These guild ideals were derived from a desire to produce at ARCOP the best architecture available without emphasizing the individual hero or personality cult.

For the Place Ville Marie project, a joint venture between I. M. Pei & Associates and ARCOP, Affleck was selected by Ieoh Ming Pei (b.1917) in early 1958 as Partner-in-Charge for ARCOP<sup>[39]</sup>. However, due to Affleck

and Sises's left-wing antecedents , they were not initially welcome to enter in United States for the early meetings held at Pei's New York City design office<sup>[40]</sup>. For the years to come and the same obvious reasons, ADDLMS would not be naturally favoured by the Montreal business society and political leaders either.

As early as 1955, the New York firm of Webb & Knapp Inc. had been trying to develop a mega-project for the Canadian National Railways property featuring a huge and ugly urban hole covered with railway tracks and disfiguring the Montreal downtown core for thirty years<sup>[41]</sup>. William Zeckendorf (1905-76) was the legendary president of this American development company and Ieoh Ming Pei, his in-house architect. Their project featured a new office tower for Montreal, the largest yet to be built.

A bold cruciform tower concept was evolved as part of their 1955-56 initial project<sup>[42]</sup>. With the nomination of Henry N. Cobb (b.1926) as Partner-in-charge of design for I.M. Pei & Associates, other innovative concepts were developed for PVM including the underground shopping concourse, absent from the original masterplan. It was derived from the CNR facilities urban context and the necessity to build underground links and pedestrian passageways<sup>[43]</sup>.

At their public project presentation, Zeckendorf declared that he would build “a city within a city”, meaning a self-sufficient center in which all requirements for everyday life would be found including office space<sup>[44]</sup>. In 1957, the Royal Bank of Canada decided to become a major tenant of the future multi-functional complex. The preliminary project was revised and the four quadrants at the lower level of the tower were introduced as main banking facilities<sup>[45]</sup>. In full contrast to the aluminum curtain walls, these

clearly articulated limestone veneered pavilions enhanced the composition of the plaza, circumscribing the space, offering human scale to the plaza users, integration to the urban context and a strong base for an elegant Modernist quadrupartite tower. Construction began in 1958 after the Royal Bank had signed a 99-year lease for 20% of the cruciform building<sup>[46]</sup>.

After I. M. Pei had selected ARCOP, the firm became the associated resident architects based in Montreal. With Cobb's complete authority on the design, there was little opportunity for Affleck and the other partners to introduce their design ideas and they unsuccessfully tried to develop some design dialogue<sup>[47]</sup>. A source of frustration and disappointment for all its partners, ADDLMS was restricted to the production of the contract documentation and the subsequent construction supervision, insuring the coordination between engineers, contractors and city bylaws officials as well as the liaison between New York City and Montreal<sup>[48]</sup>.

The PVM Project was technically divided into three major areas featuring the Tower, the Bank Quadrants and the Lower Level. From the fall of 1958 through the spring of 1959, the concept of the "under city development" was heavily developed by Vincent de Pasciuto-Ponte (b.1919), a talented city planner and associate in charge of the city planning section at I. M. Pei & Associates<sup>[49]</sup>.

While Dimitri's specific design strengths were never recognized by the Pei team, the former participated at client meetings and a few partners' discussions on business relationships. Subsequently, Affleck made frequent trips to New York City and soon became very upset with the condescending attitude of I. M. Pei & Associates. In Montreal, ARCOP occasionally held internal critiques on the design as it progressed in the New York office.



At one, Desbarats criticized the inefficiency of the Italianate unobstructed pedestrian plaza design, rejecting its location above the lower shopping concourse hidden below. Desbarats evolved a completely different scheme favouring a lower level and outdoor inter-connection. Later presented in New York, the alternative scheme was rejected by Cobb<sup>[50]</sup>.

At that time, Affleck tended to bring Dimitri for design discussions in New York City, but neither would ever make their point. Never strongly involved in any way on the subsequent design of Place Ville Marie, Dimitri was only occasionally present at presentations and critics like the other partners of ADDLMS.

The Project development was carried over by Webb & Knapp (Canada) Ltd., holding 49% of the shares of Trizec Corporation Ltd. owning PVM. While William Zeckendorf Junior was the vice-president and director of both Canadian companies, he rented office space to the Royal Bank on a 99 year lease basis after which it would take possession of the building. Complementary to the main structure, the Esso Building, located on Cathcart Street and including 92,500 square feet of rentable space, was rented mainly to the Imperial Oil Company<sup>[51]</sup>.

As the first phase of the project was completed in September 1962, the \$105 million construction complex featuring more than three million square feet of floor space, included firstly the Royal Bank of Canada Building. The \$80 million and 42-storey cruciform tower contained one and a half million square feet of rentable space wrapped up in elegant aluminum and glass curtain walls<sup>[52]</sup>. The complex also included an exterior plaza adorned with orthogonal motifs, two plantation boxes and a water basin with four fountains. It was pierced with four large opened stairwells leading to the

shopping mall, an underground promenade with parking facilities for 3000 cars. Complementary features included the Esso Building, a four-storey linear structure faced with Indiana limestone defining the plaza limits on the north side and respecting the scale of the surrounding buildings<sup>[53]</sup>.

The grand opening of PVM took place on September 13, 1962. For the occasion, Quebec Premier Jean Lesage (1912-80), Montreal Mayor Jean Drapeau (1916-99), Cardinal Paul-Emile Léger (1904-91), Donald Gordon, president of the CNR, Earle McLaughlin, president of the Royal Bank, James Soden, president of Webb and Knapp (Canada), and William Zeckendorf himself gave short addresses to a crowd of 1500 guests, including ARCOP representatives, assembled for the occasion on the plaza<sup>[54]</sup>.

The latter mentioned that PVM was not the task of a single man but of a community of engineers, architects and contractors of great class. The "New Heart for Montreal", it featured the largest office structure in Canada and the Commonwealth, and the largest cross-shaped building in the world. On the same occasion, another 13-storey office building was announced for the next year as part of the second phase of the project<sup>[55]</sup>. Designed by the same architects, the IBM Building would later be added on the south-west side of the site, beside the Richardson Greenshields Building to the north-west. Matching in spirit the Esso Building, it would become another elegant Modernist structure featuring a classicised colonnade at street level.

In June 1958, ADDLMS was officially commissioned to design the first phase of Place des Arts consisting of the Grande Salle main building. Initiated simultaneously by ARCOP, a Masterplan was also completed in 1959 after the preliminary design of the Grande Salle <sup>[56]</sup>. Both met the requirements of an economic study made for the Sir Georges-Etienne

Cartier Corporation. The latter, of which Jean Drapeau, then mayor of Montreal, Claude Robillard, Bartlett Morgan, Samuel Bronfman, and other public notables and subscribers were members, had been created in 1956 to establish a new concert hall in Montreal<sup>[57]</sup>. As early as August 1957, the Raymond Loewy Corporation of New York had been hired to do the economic study. Through news reports, the ARCOP partners found out early about the creation of the Corporation including some members which they knew personally. They also learned unofficially about the nomination of a local and undistinguished architect for this important commission. It was in fact an arrangement allowing the Raymond Loewy firm to develop the design after the preparation of the program<sup>[58]</sup>. This American firm was however not registered in United States as an architectural office.

Since the Queen Elizabeth Theatre had won a Massey Medal in 1955, the partners began their own campaign to obtain the contract. Through Jean Michaud and Hazen Size, claims were addressed to influential members of the Corporation such as Drapeau, Robillard and Morgan. A letter was also sent to the Quebec Premier Maurice Duplessis (1890-1959) threatening to undertake a press campaign to eliminate the American firm<sup>[59]</sup>.

ADDLMS was finally awarded the commission after the Raymond Loewy Corporation had been found guilty of practising illegal architecture in the Province of Quebec<sup>[60]</sup>. The latter was soon rehired as “Project Coordinator” by the Corporation while ARCOP was proceeding with the design<sup>[61]</sup>. Having displeased the Board because of its daring procedure to obtain the commission, ARCOP irritated it further with its ambiguous project leadership and the disturbing presence of the six partners at the presentation meetings held by the clients<sup>[62]</sup>.

Initially, Desbarats promoted some kind of Modernist Gothico-Picturesque composition for a Grande Salle, to be located on a site partially occupied by a brick building and a hilly ground with trees on Sainte-Catherine Street<sup>[63]</sup>. After the presentation of a few studies and sketches, Jean Drapeau sternly warned them that he would not tolerate an English, Protestant, square, angular and brittle composition like their Vancouver Auditorium. He would rather accept a French, Catholic, Classical, curvilinear and feminine design for his Montreal project<sup>[64]</sup>.

Since ARCOP had not yet found its final design concept, Drapeau's exhortation stimulated the creativity of all partners. The initial version of the masterplan featured a rectangular Opera Concert Hall of 3100 seats facing a central piazza partially enclosed by stores and restaurant on Sainte-Catherine Street. It was sided by a theatre of 1250 seats to the west and a chamber music hall of 500 seats to the east, both complemented by underground parking facilities.

By January 1959, the second version featured a similar layout with a revised horse-shoe configuration for the monumental Grande Salle classically designed on symmetrical axis (fig. 15). Other complementary changes were also made throughout the site<sup>[65]</sup>.

The aim of the Place des Arts masterplan was to provide a visual and social focus at artistic level in the heart of Montreal. Reflecting the great European traditions for such centres, the predominantly symmetrical piazza would invite the passers-by in a protected urban space forming an anti-chamber and pedestrian climax before reaching the main building<sup>[66]</sup>.

The Grande Salle was basically designed as a multi-purpose hall suitable for symphonic performances as well as opera, ballet and musical comedy.

For the last three uses, it required a large, vertical and massive stage-house. By combining the stage-house and auditorium volumes, the building was gaining a more unitary quality. Ultimately three volumes emerged from the early design process: the dominating central mass, the horse-shoe lower peripheral ring and the backstage lower mass. The building volumetry and geometry were developed in a classicizing Modern Formalist idiom answering all basic functional and structural requirements.

Evolved by Dimitri from the program, the horse-shoe shape of the lounge and lateral foyers was derived from the main hall enclosure which would allow lateral access through the use of continental seating.<sup>[67]</sup> A front curvilinear outline also favoured the generation of an external supple and plastic juxtaposition of masses<sup>[68]</sup>. One morning, Dimitri came at the office with a small miniature model made from an empty powder box of his wife<sup>[69]</sup>. This very simple cardboard model at tiny scale was very influential for the subsequent design development which led to the final tripartite massing of the Grande Salle.

While Lebensold was bringing the idea of the front colonnade with glazed partitions, Bill Snaith, the President of the Raymond Loewy Corporation who was responsible for the interior design elements, proposed a solid envelope without glazing, following Dimitri's form<sup>[70]</sup>. His idea was immediately rejected. Enduring conflicts resulted in identifying architectural and interior design items. For these reasons, the working relationship between ARCOP and Snaith became untenable. He antagonized the partners particularly Desbarats, and his firm was finally removed from the project<sup>[71]</sup>.

Dimitri soon produced a beautiful free-hand drawing of the revised shape later approved at one of the weekly partners' design meeting<sup>[72]</sup>. Knowing

that such form would be much more difficult to develop, the group was excited by its challenge and kept working at its geometry and mathematical logic. By January 1959, three versions of the horse-shoe scheme had been studied dealing mainly with changes in the overall massing and the lateral and vertical access to the main hall (fig. 16)<sup>[73]</sup>.

All partners were involved in the design process, but most particularly Dimitri and Desbarats. Following the intervention of his friend George Cavadias, who taught mathematics at McGill University, Dimitri gradually established the curvilinear shape of the horse-shoe with exact measurements<sup>[74]</sup>. As a design team, all the partners contributed enthusiastically to the development of the floor plans, the massing and the elevations. The pleasant form of the central lounge and lateral foyers was enhanced in elevation by a grand peristyle featuring a rhythmic colonnade concealing a glazed curtain wall. Beams would support externally the lateral foyers on each side. The classicizing peristyle would contrast harmoniously against the smooth surface of the main volume to be topped by a copper roof.

Designed for the intermissions, entry and exit, the horse-shoe lounges, with piano nobile and lateral foyers, provided a dynamic counterpoint space to the main hall with everchanging views and continuous spatial flow<sup>[75]</sup>. In the main hall, continental seating would allow more comfort, safety and intimacy while three superimposed levels of balconies and lateral boxes complementing the main floor seating would offer great visual acuity (fig.17)<sup>[76]</sup>.

Stepped back one above the other with high ceiling space, they would offer a minimum of overshadowing and a feeling of closer intimacy and stage proximity. The sophisticated acoustical ceiling, suspended in space, would provide extended reverberation time, sending the sound directly

to the listeners while concealing the miscellaneous equipments.

In the later stage of the design, Desbarats became mostly responsible for the main interior spaces, including the grand hall for which he designed the acoustical ceiling, the seating boxes, the balcony fronts and railings<sup>[77]</sup>. Heavily involved in interior details, he was ultimately author of the highly original and sculptured Venitian chandeliers running on the piano nobile lounge ceiling<sup>[78]</sup>. It fitted perfectly well with the multiple artworks that would later be displayed by visual artists such as Louis Archambault, Jordi Bonet, Robert Lapalme, Micheline Beauchemin and Alfred Pellán<sup>[79]</sup>.

The plastic study of the exterior precast concrete panelling was also part of his contribution and all of these items displayed geometrical or sculptural qualities. Design assistant under Desbarats' supervision since 1958, Eva Vecsei (b.1930) produced for the project two perspectives, interior and exterior, later printed by Jean Drapeau in postcard format (fig. 18)<sup>[80]</sup>.

Many subsequent client's meetings proved to be difficult and Lebensold gradually asserted his leadership over the project development<sup>[81]</sup>. This was due to his diplomatic abilities, his performing arts expertise and his former experience on the Vancouver Auditorium. While Jerry Miller (b.1934) became the project architect responsible for the production of the contract documentation, Lebensold emerged as the Partner-in-charge during construction<sup>[82]</sup>. Special concerns were given to interior finishes which received sophisticated treatments, varying in texture, pattern and color<sup>[83]</sup>. Ultimately, the building displayed great harmony in all its parts relating to the whole<sup>[84]</sup>.

The official inauguration of the construction works for the Grande Salle as well as the underground garages and services by David Barott Boulva architectes, took place on February 11, 1961<sup>[85]</sup>. By December 14, 1962,

the Grande Salle had its roof completed and Place des Arts was well built by General Contractors Quemont-Duranceau (fig. 19). The \$23 million overall cost included \$9 million for a building slightly over budget due to many extras requested by the client<sup>[86]</sup>. As he had in Vancouver, Lebensold performed very well during the third stage of the project. This greatly benefited his own reputation, although this was at the expense of the other partners<sup>[87]</sup>.

On September 21, 1963, the inaugural concert was held in the Grande Salle (fig. 20)<sup>[88]</sup>. For the occasion, Dr. Wilfrid Pelletier (1896-1982) and Zubin Metha (b.1936) both conducted the Montreal Symphony Orchestra<sup>[89]</sup>. Among the guest of honours, one could find Quebec Premier Jean Lesage, Mayor Jean Drapeau and President Louis Lapointe whose inaugural speech did not pay tribute to the remarkable achievement of the architectural firm<sup>[90]</sup>. For the building's opening ceremonies, Lebensold managed to have a larger than life-size photo of himself at garage level, on the main entrance axis where all the people were circulating<sup>[91]</sup>. Dimitri was very angered and deceived by this new breach to their Co-Partnership teamwork agreement.

Following a series of local newspaper articles and booklets in September 1963, Time Magazine and Maclean's published two articles on the dynamic firm and its remarkable buildings. In its January 1965 edition, the latter was identifying the ARCOP partners as some of the most outstanding Canadians in 1964 (fig. 21)<sup>[92]</sup>.

A Massey Competition Finalist in 1964, the Grande Salle was always considered a major architectural landmark<sup>[93]</sup>. With the later expansion of Place des Arts, featuring the new Theatre Maisonneuve building, 1964-67, by David Barott Boulva, including two smaller rooms, the Grande Salle became the Salle Wilfrid Pelletier. Since then, it has had a dominant and



lasting social impact in the life of Montrealers. The Place des Arts was ultimately completed with the adjunction of the new Musée d'art contemporain, 1984-92, by Jodoin Lamarre Pratte architectes, to the west and the quadrilateral plaza completion by Dimakopoulos & Partners in 1988-93<sup>[94]</sup>.

The Saint-George Greek Orthodox Cathedral, located at 2455, Côte Sainte-Catherine Road, Outremont, was another project developed by Dimitri in mid-1958 and mostly built by late 1960<sup>[95]</sup>. It was part of a larger scheme including a community centre, school, priest's and bishop's residence. The commission was awarded to ARCOP, with Kimon Caragianis (b.1926) as associate architect<sup>[96]</sup>. Kimon's main role was to help secure the commission, assist at client's meetings and proceed with the construction supervision; Dimitri took charge of the design and carried out all the conceptual studies and preliminary design<sup>[97]</sup>. The latter also supervised a small team of assistants for the contract documentation. The construction was started as early as May 1959, but a first general contract of \$547,000 was only awarded on September 19, 1959 to Douglas Bremner Contractors & Builders by the Hellenic Canadian Community of the Island of Montreal of which Phrixos B. Papachristidis was the president<sup>[98]</sup>. On January 6, 1962, the interiors having been completed, the church held its first religious service<sup>[99]</sup>.

As for other ARCOP churches done by Desbarats, the partners felt that these were very personal projects involving personal clients, and that they should give each other a minimum of interference<sup>[100]</sup>. Similarly, other small commissions were much easier to deal with in terms of the selection of a Partner-in-charge.

On this occasion, Dimitri designed a building that turned out his finest

so far. Standing, austere and beautiful on its site facing Côte Sainte-Catherine Road, the concrete structure wrapped up in a brick veneer was crowned by an elegantly modulated sculptural dome (fig. 22). Alluding to the richness of the soul concealed within the human body, the spatial richness of the interior was hidden behind the elegant simplicity of the exterior walls<sup>[101]</sup>. On the interior, the ground floor symbolized Earth and the exposed precast concrete dome, Heaven. A challenging confrontation between past and future was also achieved through the integration of Orthodoxy and Modernity in the design<sup>[102]</sup>. Similar to sixth century AD Byzantine churches, the building enclosed the traditional rectangular space of a basilica topped by a dome (fig. 23)<sup>[103]</sup>. The building reconciled Greek Orthodox liturgical traditions and Modernist architectural expression rendered through structural engineering and building technology. It also satisfied the social and religious needs of a Modern Greek Orthodox community relocated on the North American continent.

Complemented by a separate brick campanile and a concrete entrance bridge, the building featured serrated brick wall panels set within glazing strips ornamented with metal grilles. These hollow brick walls were designed to create acoustical wedge-shaped cavities in the large interior space<sup>[104]</sup>. The glazing strips allowed the natural exterior light to filter inside the church with variable intensity, illuminating magically the highly textured interior surfaces.

The zigzagging lamella-type roof was crowned by a dome in precast sections covered externally with copper. Structurally, the poured reinforced concrete grid roof transmitted its load to eight free-standing concrete columns through exposed steel cylindrical knuckles separating and articula-

ting the roof structural system<sup>[105]</sup>. Set within the grid roof, a concrete beam tension ring supported the precast concrete sections of the dome, exposing their internal faces visible from below (fig. 24).

Resting on concrete beams, the floors and mezzanines consisted in cantilevered slabs supporting the lateral exterior walls. Interior finishes consisted mainly in exposed concrete ceilings, brick patterned walls, terrazzo and asphalt tile floors, complemented by oak fixed furniture<sup>[106]</sup>. Displaying some Wrightian secondary hexagonal plan patterns, the design featured coarse brick and concrete interior details, providing a Brutalist purity and masculine vigour thought to be expressive of moral truth. Evolved from archetypal abstraction, the form-given structure was truly expressive of its author's personality and sculptural originality<sup>[107]</sup>.

Similar to Frank Lloyd Wright's highly creative and brilliant Annunciation Greek Orthodox Church at Wauwatosa, Wisconsin, 1955-61, Dimitri's Greek Orthodox Church offered references to the Byzantine past and reflected some truly Modern Formalist aspirations<sup>[108]</sup>. Both compositions were however completely heterogenous, the former featuring a large dome inspired from Haghia Sophia and cantilevering above a circular building structure<sup>[109]</sup>.

Prior to 1960, ADDLMS had already started to disintegrate. By the end of 1959, Jean-Charles Michaud had left the firm, following a short period of four years during which he had played an important role in the commissioning of some projects such as the TMR Federal Post Office and the Place des Arts<sup>[110]</sup>. Pleasant, amiable but not very self-confident, Michaud, who came from a wealthy French Canadian family, had provided local balance to a firm composed of French and English Canadians, Jewish and

Greek immigrants<sup>[111]</sup>. It allowed the firm to benefit from an unprecedented mixed presence in the various Montreal commissioning circles.

As a participant in partners' meetings and design sessions through the various planning stages of important projects, Michaud's contribution was however not sufficiently steady and significant to justify a longer involvement within the firm. Officially listed as a partner of ADDLMS until the completion of Place Ville Marie and Place des Arts in 1963, he had set up his own independent office at 2040 St-Mathieu by the summer of 1962, while ADDLMS was renamed ADDLS<sup>[112]</sup>.

From Irene's birth until 1961, Dimitri's small family evolved smoothly, residing on Besboro Avenue, except for a two weeks' leisure trip to Jamaica<sup>[113]</sup>. By the end of 1960, Lydia had become pregnant with a second child. Undergoing a difficult pregnancy, she suffered from nausea, lack of appetite and low weight gain, inciting Dimitri to bring the family to Morin Heights for a few days holiday. On August 21, 1961, Lydia gave birth to Marina, her second and last daughter, without major complications<sup>[114]</sup>.

Two years later, Dimitri's enlarged family moved to 6030 Côte Saint-Luc<sup>[115]</sup>. However, it was just a temporary address, and, by August 1965, the family was relocated at 5765 Côte Saint-Luc, a brand new building equipped with a swimming pool<sup>[116]</sup>. Located at #201 on the second floor and offering a nice view on the garden lawn, the luxury apartment included two bathrooms and three bedrooms, one of which was used as a playroom.

During the early 1960s, Dimitri had been involved in a series of new projects, namely the Norman Wade Building, Pointe-Claire, 1961-2, the Summerlea Golf & Country Club, Pointe Cascades, PQ, 1960-63, and the National Competition for the Fathers of Confederation Memorial Building,

Charlottetown, Prince Edward Island, 1961-64.

Designed to house the administrative offices, warehouse storage and printing facilities of the company drafting services and equipment, the first building featured a one-storey rectangular exposed structure with complete free-plan layout for the interiors (fig. 25). This was requested by the program for a greater flexibility of operations<sup>[117]</sup>. The project evolved by Dimitri as Partner-in-Charge displayed an autonomous sculptural quality and answered to the zoning regulations and by-laws requirements of the industrial park in which it was located, offering an architectural challenge for personal expression.

Dimitri's final scheme featured two external rows of eleven reinforced concrete columns interconnected by beams and poured altogether into two continuous lateral colonnades. Each of them supported a series of 63'-6" long prestressed post-tensioned single Ts roof beams through structural steel knuckles articulating clearly and separately the colonnades from the roof structure sub-systems<sup>[118]</sup>. Above and between the prestressed beams ran a mill deck roof.

The resulting plan offered no interior columns or bearing walls, the interior finishes consisting mainly in exposed concrete, glazing, and concrete block on the perimeter, gypsum board, transite panels and wood partitions in the central area (fig. 26)<sup>[119]</sup>. The front façade and the three first lateral bays displayed glazed partitions offering optimized daylight illumination for the office area, while the rest of the building featured a purple brick exterior veneer harmonizing in winter with the neighbouring tree trunks<sup>[120]</sup>. These materials were complemented by the exposed concrete and metal cladding.

Perfectly integrated to its surroundings, this simple utilitarian building stood harmoniously in the clearing of a treed area. Its architectural value was enhanced by the large open grounds. Under sunlight illumination, the deep reliefs of its Structuralist façades offered an interesting play of light and shade generating dramatic chiaroscuro effects throughout an exciting rhythmic composition. In this project, the perfect Miesian box had been concealed under a structural table. Translated into a Modernist idiom, the pure forms of Classical porticoes and pediments found in ancient Greek temples were echoed in a Modernist classicizing composition. The designer demonstrated his strict and severe sense of Hellenic elegance, equilibrium, stability and strength<sup>[121]</sup>. In 1964, he was a Massey Competition Finalist<sup>[122]</sup>.

In 1960, Dimitri teamed up with Desbarats to design a proposal for the Summerlea Golf & Country Club limited competition<sup>[123]</sup>. Making an attempt at Modern Regionalism, they won the first prize and commission with a scheme based on a “Fort Chambly” image proposed by Desbarats, of which Dimitri made the perspective. Their submission also featured a building design “in the character of Dimakopoulos beautiful structures”<sup>[124]</sup>. Affleck, familiar with the client, took over the project, modifying the composition of the winning scheme. The resulting building looked more squashed and flattened, with looser fenestration<sup>[125]</sup>.

The \$750,000 building program requested bag storage, pro shop and lockers room, lounge, bar and grill, as well as administrative facilities for a clubhouse for the new 36-hole golf course (fig. 27)<sup>[126]</sup>. The country club was dramatically located on a ridge allowing on both sides some panoramic views on the Ottawa River and the golf course. The two longitudinal elevations featured reinforced concrete linear elements expressed externally by

two colonnades with continuous roof beams cornice and shaded balconies at lower level (fig. 28). Massive and flattened, the hexagonal columns featured slim protruding concrete drips at the cornice intersections<sup>[127]</sup>. Stone masonry and glazing were the complementary exterior wall materials, while carpet flooring and cedar board walls were used as interior finishes. The landscape architecture was conceived by the golf course architect<sup>[128]</sup>.

Launched on September 1st, 1961, the National Competition for the Fathers of Confederation Memorial Building was organised to provide a commemoration for the upcoming centenary of a meeting that took place on September 1st, 1864 in the Confederation Room of the Province House in Charlottetown, P.E.I.<sup>[129]</sup>. It involved some Maritime representatives and a Canadian delegation that came to discuss the reunion of the three British colonies of Upper and Lower Canada, New Brunswick and Nova Scotia into a new Confederation that would later be established in 1867<sup>[130]</sup>. The Legislature Building where the Fathers met had been built in 1847 by the British architect Isaac Smith (c.1795-1871), born in Yorkshire<sup>[131]</sup>. Of Georgian Revival style, it had since become a venerable centenary structure, covered with dressed Wallace sandstone, displaying Ionic porticoes on its front and rear longitudinal façades<sup>[132]</sup>. Presenting a strong personality, it was the focus of Queen Square, a 6.3 acres rectangular park situated in the heart of little Charlottetown featuring a population of 20,000 habitants<sup>[133]</sup>.

The competition was directed by a jury of seven members including the British architect Sir Basil Spence (1907-76), and attracted forty seven competitors<sup>[134]</sup>. The building program conditions imposed the dual functions of a Memorial Hall and a Cultural Centre. The former would also serve as an entrance hall to the whole complex, and a connecting link between the

Cultural Centre's main elements, namely a library, a theatre, an art gallery and museum. The program stated that the competition was an opportunity of designing a building for centuries, an everlasting shrine situated at the birthplace of the Canadian nation<sup>[135]</sup>. Rather than a dead and solemn monument, it would serve as a lively place in downtown Charlottetown. Surrounded by an early 19th Century townscape, it would preserve its delicate and miniature urban scale and offer harmonious integration to the existing Legislature Building and its immediate context.

ADDLS proceeded with the competition project in the fall of 1961, its design submission becoming the “last true ARCOP triumph and team effort”<sup>[136]</sup>. The firm associated for the occasion with the town planner Norbert Schoenauer (b.1923) in a joint registration<sup>[137]</sup>. Civic design considerations preceded the architectural design process. The design team first established the working framework. Evolved in direct answer to the program requirements, a first principle was to integrate and complement harmoniously the old and new buildings. A second one was to provide a focal point and urban climax to Charlottetown. In complement, a third was to attract people on the site with inviting exterior “concave” spaces<sup>[138]</sup>.

Following the analysis of the site from various point of views, the architectural design process consisted in placing the new building on the site in relation to the Legislature, the city streets and surroundings, maintaining the quality of the landscaped opened green square. Two major difficulties soon emerged from the program, consisting in the large area requirements generating a heavy building mass and the offset longitudinal axis position of the Legislature on the east third of the site. The group used its usual design strategy to its fullest potential during the development of the



basic concept. Numerous topologies were tried in progressive stages by the partners who struggled and discussed together in successive meetings (fig. 29)<sup>[139]</sup>. All sketches were worked out in joint sessions. Each of these attempts presented defects in relation to the Legislature contextual objectives consisting in pleasant axis linkage, mass integration, preservation of scale and Classical quality of the existing structure.

During the course of one session, Dimitri, who took a clue from rough program breakdown diagrams, began to spread the program parts in compact groupings extending from the Legislature Building<sup>[140]</sup>. The west side provided the largest free area to group the required facilities. By making each main element a separate building, except for the combined art gallery and museum, the scheme would avoid offense to the Legislature. In the brain storming session that followed, another partner suggested to build a podium, to lower part of the program requirements underground and to keep only above ground the symbolic elements of the scheme, namely the theatre, the library and the art gallery/museum units complemented by the Memorial Hall. Dimitri immediately developed further this concept, adding the semi-underground entrance lobby on axis with the Legislature<sup>[141]</sup>. He was ultimately responsible for the general site plan (fig. 30).

At this stage, the final concept was close. A uniform height matching the cornice line of the existing building was established. The Memorial Hall became an open forum cut into the terraced podium. It would be covered with a transparent glass roof contrasting with the solid enclosure of the surrounding units. While the art gallery/museum unit was developed as a northern bipartite structure with its two functions clearly articulated in plan and elevation, the Library turned out to be a southern rectangular tripartite

double-storey unit featuring a full height central reading room flanked by a Legislative Library and Open Stack Area raised on two opened mezzanines<sup>[142]</sup>. As per the Theatre, it featured a western massive block set in a simple double-storey rectangular unit (fig. 31).

Concealed in between and opening towards the Legislature and its main pedestrian street accesses, the sunken Memorial Hall was conceived as an enclosed circulation hub accessible from stepped terraces to the east and crowned by a jewel-like cluster of truncated glazed pyramids<sup>[143]</sup>. Allowing under day and night illuminations dramatic viewpoints from within and without towards the peripheral open air terraces, it fully contrasted in character with the remainder of the complex. Complementary design features were added such as two open air sculpture courts attached to the art gallery/museum and library units. Horizontal glazed slots framed by low buttressing precast walls and running along the perimeter of the units, were inserted to penetrate the podium and illuminate the sub-terrace level<sup>[144]</sup>. Similarly, thin vertical window strips were added in the recessed corners of the units, articulating rigorously the exterior walls as bold independent vertical planes covered with Wallace sandstone panels.

Fulfilling all the various functions and commemorative requirements, the final architectural concept enhanced the urban quality of Queen Square and offered perfect complementarity to the Legislature. Of great simplicity and restraint, the Modernist scheme displayed strong sculptural relationships between its parts and echoed harmoniously the Classical quality of the Legislature<sup>[145]</sup>. Displaying handsome elevations at appropriate scale, the composition presented perfect monumentality and the architectural design had no conscious precedents. Like a miniature Acropolis set in the heart of

Charlottetown, the project proposed a great urban gesture of architectural nobility<sup>[146]</sup>.

Once all partners were completely pleased with the absolute clarity and appropriateness of the design, they proceeded with the production of black ink presentation drawings including perspectives drawn by Eva Vecsei<sup>[147]</sup>. The competition submission which also included a model was sent to the organizers by the end of the year (fig. 32). Except for the Memorial Hall which was still missing its detailed concepts, all the major design elements had been established.

The jury was impressed by the high standard of design of the majority of the competitors. In general, the Legislature Building scale and significance was respected and the new complex was integrated to the site with skill and sensitivity. ARCOP's first prize winning scheme was perceived as setting "a new standard of architectural excellence and suitability" that would not likely be surpassed<sup>[148]</sup>. Its chief charm was its absolute appropriateness to the local city scene. It offered the highest respect and sympathy to the Legislature in a skilfully integrated scheme opening up towards it with dramatic effect.

Displaying great civic quality, the project offered many exciting view points on the Memorial Hall. The landscaping and terracing showed unusual sensitivity and the human scale of this most disciplined group of buildings payed respect to the urban perimeter. The plan offered the best solution in terms of spaces proportions, circulation networks and independent accesses.

The Memorial Hall was seen as a noble room expressing the Fathers' ideas by their words engraved in the stone legible with light<sup>[149]</sup>. Without dominating the whole complex, it offered human scale. The Wallace sand-

stone veneer, matching that of the Legislature, unified the old and new buildings in a solution demonstrating highest qualities without extravagance.

The results of the competition were known in January 1962. As Desbarats was taking the telephone call from the jury professional advisor, “all hell broke loose at ARCOP”<sup>[150]</sup>. Soon, the magnums of champagne were opened and the celebration went on in the offices located in the Dominion Square Building. It was the happiest moment in ARCOP’s history<sup>[151]</sup>.

To celebrate all winners, a dinner was organized in the Ballroom of the Château Laurier on January 30, 1962<sup>[152]</sup>. For the occasion John Diefenbaker (1895-1979) pronounced a magnificent discourse in front of many guests. The Governor General also presented the prizes to the representatives of the four winning firms<sup>[153]</sup>. Wearing tails and white tie, Dimitri attended with his wife and the Desbarats couple at the joyful ceremony (fig. 33)<sup>[154]</sup>.

Since Dimitri’s contribution had been so decisive and it was more than his turn to lead a major project, he was immediately selected as the Partner-in-Charge of the project. From then on, it was assumed that his own conceptual ideas had generated the winning concept and its synthesis had been achieved through a joint effort<sup>[155]</sup>. A short transition period took place between the competition results and the award of the commission<sup>[156]</sup>.

In the summer of 1963, ADDLS moved its offices from the Dominion Square Building into its newly designed building located at 6865 Western Avenue<sup>[157]</sup>. Introducing more Greek feeling into the Charlottetown project, Dimitri carried on with the detailed design development, assisted by Hans K. Stenman (b.1935), Project Manager, and Vincent Chan, Design Development Assistant<sup>[158]</sup>.

The other partners had very limited involvement during that phase and

the subsequent construction documentation stage. All design details were developed under Dimitri's supervision. Only difficult questions were presented to the other partners in relation to technical problems and Desbarats discussed with him several exterior details<sup>[159]</sup>. Since all partners were very busy on other projects, the partnership became much more individualistic and internal competition followed between each team.

While technical theatre details were developed through the services of American consultants, the Memorial Hall roof design, to be completed only in the fall of 1963, was not ready when construction tenders were called in January<sup>[160]</sup>. The contract was awarded to Pigott Construction of Ontario in February and construction started in March. Client relationships became difficult since the general contractor's performance was inadequate, generating delays in the building completion schedule. Discipline on the construction site was also poor and ARCOP had eventually to dispatch a construction manager to speed up the work and insure quality performance<sup>[161]</sup>.

The construction schedule called for total completion of the complex by May 1964. It had to be ready for the Dominion Drama Festival taking place in the new theatre<sup>[162]</sup>. Only the theatre opened at that date, and Dimitri attended with his wife at its inauguration featuring an oyster dinner and play (fig. 34). For the occasion, Jean Lesage, of the Parliamentary Commission Committee and the Governor General were present<sup>[163]</sup>.

A stamp featuring the whole complex was issued on July 29, 1964 by Canada Post (fig. 35)<sup>[164]</sup>. On September 1st, the new buildings were dedicated to the Fathers, precisely one hundred years after their historical meeting<sup>[165]</sup>. Dimitri had them completed nearly on time. On October, 6 1964,

Her Majesty, Queen Elizabeth II (b.1926) hosted the grand official inauguration for which Dimitri was present (fig. 36)<sup>[166]</sup>. His \$7.5 million complex turned out to be one of ARCOP's most successful project, but contrary to Lebensold and Affleck, it never brought him much personal publicity<sup>[167]</sup>.

In 1962, the winning of this competition also brought another major commission to ARCOP from the Department of Public Works of Prince Edward Island<sup>[168]</sup>. With Dimitri as Partner-in-charge, the Provincial Government Centre project was designed in late 1963-64. It featured a large complex to be located in a park setting in Charlottetown<sup>[169]</sup>. The program called for two separate buildings, one containing office space for government departments and public services, the other, office space for provincial medical health services<sup>[170]</sup>. The bent rectangular site included two five-storey buildings with basements, namely the Administration Building, a linear structure subdivided into three areas facing the east, and the Health Centre, layed out on square plan to the north<sup>[171]</sup>. Both featured rectangular service shafts protruding from their perimeter. The site was bordered by four streets. On the west, was laid out a large parking lot planted with trees and on the south, a landscaped park and paved court with square pool surrounded by terraces. Around the perimeter of both buildings were laid out pedestrian paved areas and tree plantations. Large access steps were located to the north between the two buildings.

The linear structure included at ground floor three halls with offices delimited by two transversal recessed lobbies leading to two stairwell shafts at the back<sup>[172]</sup>. In general, the upper floors featured two external rows of offices with two transversal lobbies including opened mezzanines and light wells. Two other stairs were found in the shafts located on the short sides.

The elevations included four blind towers with concrete vertical panels on six storeys. The three bays in between featured exposed concrete frames and fixed window units equipped with lower opening sashes. The three upper storeys displayed four groups of four windows in each bay, while the second floor was mostly glazed except for lower and upper continuous blind strips. The ground floor was similar with wider window panes. Articulated with blind protruding towers, the two end elevations were mostly faced with rectangular concrete panels (fig. 37)<sup>[173]</sup>. As per the flat roof, it featured two large skylights above the transversal halls with light wells<sup>[174]</sup>.

Laid out on a square plan with protruding shafts in each corner, the Health Centre featured at ground floor a large opened hall to the east with main service core at the back and peripheral offices on the three other sides<sup>[175]</sup>. The upper floors featured peripheral offices, central square corridor and internal service rooms area with corridor going through. Beyond the fifth floor, a recessed rectangular penthouse protruded from the roof similarly to the four corner towers<sup>[176]</sup>. Each elevation featured four bays of four vertical rectangular windows on the three upper floors. The second floor was mostly glazed with two blind horizontal bands. The ground floor bays were mostly blind except for thin horizontal ventilation windows<sup>[177]</sup>.

This Modernist complex, constructed in 1964-65, offered pleasant surroundings, perfect location and massing inter-relations<sup>[178]</sup>. Articulated with secondary volumes breaking down their masses, they offered a common ratio of proportions brought down to human scale in the vertical windows and exposed concrete panels. The two structures offered a feeling of compactness, balance and lightness due to their large glazed surfaces

set within slim frames contrasting with the bold treatment of their blind concrete surfaces set in separate planes. Their fine proportions and exquisite detailing echoed Dimitri's personal style at the time, characterized by restraint and meticulous concern. Unpublished, they however never received much attention, publicity or grants<sup>[179]</sup>.

In mid-1963, the Concordia Estates Development Co. firm, regrouping three young entrepreneurs graduated from McGill, asked ARCOP to prepare a proposal for the design competition of a large complex that would later become Place Bonaventure<sup>[180]</sup>. It was located over a circulation node including railway tracks, subway lines and underground highways, south of the CNR Central Station in downtown Montreal<sup>[181]</sup>. Lebensold and Desbarats decided to work at it with some minor participation from the other team members<sup>[182]</sup>. As a consequence, Dimitri was involved when the conceptual design was prepared.<sup>[183]</sup>

They won the competition with a massive low-rise scheme inspired from a "Fort Chambly" image, contrasting with common high rise structures and offering a strong presence for a building housing multiple functions such as exhibition hall, sales hall and shopping concourse. Desbarats brought to the original scheme strong exterior corners and architectural interiors with Union Jack patterns of circulations linked to the pedestrian street and subway networks<sup>[184]</sup>.

After the commission of Place Bonaventure was secured, Affleck was forced to take over the project development in 1964, as Partner-in-Charge. Unhappy, he left the Ottawa National Arts Center commission to Lebensold. The latter would be seconded on a part time basis by Desbarats who was also deeply involved on the Expo' 67 Theme Pavilions as well as other



projects. Affleck kept the design team meetings going on Place Bonaventure during the important early phase of planning<sup>[185]</sup>.

Influenced by the European Neo-Brutalist school, Affleck struggled for a while with the elevations until Eva Vecsei was invited to join him as architect of composition for the preliminary design. While Desbarats could give some of its character to the La Gauchetière elevation, Affleck took control of the rest of the project including the Hotel Bonaventure on top which later proved to be a great success<sup>[186]</sup>.

ARCOP had developed an expertise in fine sculptural concrete work and all partners were interested in the Neo-Brutalist concrete approach recently developed in England and USA. Impressed by the quality of the Yale University Art and Architecture Building, New Haven, 1959-63, by Paul Rudolph (1918-97), Dimitri had visited the site shortly after its opening<sup>[187]</sup>.

The huge elevations of Place Bonaventure were soon broken up into a mosaic composition reflecting the city while Rudolph's "corderoy" concrete treatment and protruding glazed boxes were adapted to the project<sup>[188]</sup>. During a design meeting, Dimitri proposed to add four corner glass bays to enhance the aesthetics of the elevations as well as the illumination of the lounges (fig. 38)<sup>[189]</sup>. Completing the building in 1967, Affleck took most of the credits for the design, many of its concepts originating from Lebensold and Desbarats, a few from Dimitri, and the rest from Eva Vecsei<sup>[190]</sup>.

Obtained in normal market conditions and through government lobbying, the commission for the National Arts Center, Ottawa, 1964-69, proved to be the last great success of ADDLS, considered at the time the best Canadian firm in the area of concert hall design<sup>[191]</sup>. As Partner-in-Charge, Lebensold took complete control of the project without team participation. It was his

own concept, design and follow-up. The building was conceived like a Japanese garden of many boulders in the landscape<sup>[192]</sup>. The triangular site was treated as a focal outdoor area, with terraces providing shelter, landscaping and facilities for outdoor activities<sup>[193]</sup>. Outdoor spaces were strongly related to the Rideau Canal to the north and the Confederation Square the southwest. Displaying skillfully massed forms pleasurable to move through and around, the exposed concrete structure featured a 60 degree angular plan complemented by Wrightian hexagonal idioms down into the details<sup>[194]</sup>.

Assisted by Art Nichol as Project Director, Lebensold maintained an exclusive stronghold on the project, directing the publicity on himself, in spite of the ARCOP original partnership ideals. The building turned out to be the best Modernist building in Ottawa, the best of its size and function in Canada and among the best of its kind in the world<sup>[195]</sup>. Ieoh Ming Pei himself later mentioned to Desbarats that, although not great, he considered the building to be very very good<sup>[196]</sup>. Dimitri was never involved in the design, but he could however take indirect credit through his ADDLS partnership. Winner of another Massey Medal in 1970, it was the last major success of the firm before the great collapse<sup>[197]</sup>.

The Arts and Cultural Centre, Saint-John's, Newfoundland, 1964-67, was another Maritime commission earned by ADDLS<sup>[198]</sup>. Affleck was named Partner-in-Charge for the project, with Arthur Nichol as Project Director<sup>[199]</sup>. The former was entirely responsible for the concept and execution of this complex combining concert-theatre auditorium, art museum, public library and teaching facilities<sup>[200]</sup>. Following Desbarats's attempt to suggest an interesting massing and volume, Dimitri gave to Affleck a good idea for the final grouping of the buildings, and the design was developed into prelimi-

nary drawings by the architects Rosen, Caruso and Vecsei (fig. 39)<sup>[201]</sup>. Benefiting from little publicity, the building turned out to be rather undistinguished in comparison to ARCOP's most famous landmarks<sup>[202]</sup>.

In the summer of 1966, ARCOP sold its building at 6865 Western to relocate in the Read Building, at 1015 Saint-Alexandre<sup>[203]</sup>. While another project office for Place Bonaventure had been in existence on Beaver Hall since 1963, ARCOP staff was relocated altogether, reaching its peak in the fall of 1966 with approximately 175 people<sup>[204]</sup>. During the following summer, ADDLS personnel would be reduced by half, all on the same day<sup>[205]</sup>.

Dimitri, who had originally designed a more expensive and elegant version of the ARCOP Building featuring articulated concrete columns and fancy curtain walls, never appreciated the final built version of the ARCOP's office building designed by Lebensold and Desbarats. Its remote location from the downtown area and cheaper appearance unreflective of ARCOP's architectural image were the main factors<sup>[206]</sup>.

During this period, "private" projects were also developed at the office, according to working arrangements between the partners who could use ARCOP staff and services<sup>[207]</sup>. Among these, two architecturally distinguished residences were produced, the Desbarats Residence, 48 Avenue Robert, Outremont, 1966-7, and the Dimakopoulos Residence, 461 Clarke Avenue, Westmount, 1966-7<sup>[208]</sup>.

Featuring a meticulously detailed Sculpturalist scheme, the flat roofed rectangular Desbarats House displayed a sober and elegant use of exposed concrete in conjunction with large beige brick areas perforated with vertical windows<sup>[209]</sup>. Totally different in spirit, the Dimakopoulos House was of

Aaltian influence, situated on the eastern slope of a hilly street and equipped with a set of flat terraces<sup>[210]</sup>. Displaying natural organic materials in its red brick walls complemented by natural wooden window overhangs, stone masonry and concrete elements, it featured height emphasis, angular forms and juxtaposed contrasts of materials and volumes. Like his other designs, it offered inventive freshness, sharpness and clarity<sup>[211]</sup>. Of angular rather than tactile inclination, Dimitri was mainly concerned with light and form, while a certain sculptural starkness appealed to him<sup>[212]</sup>. Well integrated in mass and scale to the older neighbouring residences, his house offered a picturesque and Modernist feeling contrasting with its surroundings (fig. 40).

Well lit by a multiplicity of windows, the interiors offered a feeling of space, with meticulous attention given to details and use of high quality materials<sup>[213]</sup>. The basement included a garage, storage, laundry, playroom and dark room. The main floor featured an opened space suite, including entrance hall, living room, dining room and galley kitchen. The second floor contained a den, two small children's bedrooms equipped with washroom and built-in storage furniture, and a spacious master bedroom including private washroom, walk-in closets with folding doors and built-in furniture. Stairs were leading to a split-level studio over-looking into the master bedroom. Through extra steps, an exterior terrace could be reached from which a spectacular view opened on the downtown area towards Nun's Island<sup>[214]</sup>.

Following a one month trip in Europe with his family in the summer of 1965, Dimitri proceeded with the purchase of the vacant lot, evolving the program, conceptual design and detailed development of his house<sup>[215]</sup>. Directing a small team to prepare the contract documents, he selected a contractor and supervised the construction of his own house until its final

completion in 1967<sup>[216]</sup>. Leaving their apartment on Côte Saint-Luc, he and his family had moved in their new residence prior to the Expo 67 inauguration held on April 28, 1967<sup>[217]</sup>.

Taking usually taxis to go to work, Dimitri was the owner of a grey/sage green Oldsmobile Cutlass car which he kept for seven or eight years before buying a new white/cream Mercedes Benz in the early 1970s<sup>[218]</sup>. With the post-Expo 67 slump, new projects became scarce and more difficult times were foreseen. Dimitri spent few short summer vacations in Cape Cod with his family and it was only in the early 1970s that he would go back to Europe<sup>[219]</sup>.

As early as 1964, Desbarats had accepted a part-time Deanship commitment at Université de Montréal in order to launch the new Faculté d'Aménagement including the Ecole d'Architecture<sup>[220]</sup>. Since he was still carrying a full load of contracts and had been involved in obtaining all major commissions, he remained a full partner during his first term with the university until June 1968. Under Desbarats' invitation, Dimitri became a part-time architectural design teacher in 1965, but the latter would quit this task only after six months<sup>[221]</sup>. During his second term of four years, Desbarats decided that it would be no longer possible to operate on two plans and, by December 1969, he proceeded to dissolve his partnership with ARCOP, working out a reasonable financial settlement with some legal assistance<sup>[222]</sup>.

Prior to his departure and following the post-Expo '67 slump, Sise was invited to gradually proceed towards full retirement. An excellent collaborator, critic and advisor, he had, in the past, contributed through his influential relations to the obtention of some important commissions. However, during all his partnership period, he never carried out a complete project on his

own<sup>[223]</sup>.

ARCOP had never been considered exclusively as a business venture by its partners; its raison d'être had been to produce architectural design at the highest possible level. Following in the steps of the Modern Movement pioneers, the four main partners had all been top students motivated to produce the best Canadian architecture available. Possessing distinctive aesthetic orientations, they were however able to work together and recognize new exciting concepts<sup>[224]</sup>. Except for Lebensold's good architectural judgment and more down-to-earth approach, they all shared an intense creative passion and sensitivity, often leading them to a more expensive and time consuming design process<sup>[225]</sup>.

While Desbarats had proposed to his partners some policies to survive the post-Expo '67 slump, a clear dynamic developed between the two "establishment" and two immigrant partners, their professional orientations becoming divergent<sup>[226]</sup>. Following Desbarats and Sise's departure, there was a general feeling shared by the partners, associates and employees that the ARCOP's ideals were no longer maintainable<sup>[227]</sup>. Rather than growing horizontally, the new working relationships became much more paired off and vertically structured. Affleck would work with Tom Blood and Eva Vecsei, Lebensold with Art Nichol, and Dimitri with Stenman and Vecsei<sup>[228]</sup>.

As early as December 1966, the Canadian Government Exhibition Commission announced a National Competition for the design of a Canadian Pavilion at the Japan World Exposition, Japan, 1970. For the occasion, the internationally renowned Kenzo Tange (b.1913), responsible for the masterplan, was appointed as a member of the jury<sup>[229]</sup>. Attracting 208 Canadian participants, the competition resumed to six finalists for the

first stage selection, including ADDLS. According to the jury, each submission displayed a high degree of professionalism. While these six projects were judged in March and April 1967, the second stage was ultimately won by Erickson Massey architects<sup>[230]</sup>.

Among others, William Che-Yuen Sung (b.1938) worked with Dimitri on the concept<sup>[231]</sup>. Desbarats was also briefly involved, but all partners being too busy, Thomas E. Blood (b.1935) led the submission presentation which turned out to be monochromatic<sup>[232]</sup>. Featuring a mega-sculpture made of vertical masts members assembled in two rectangular juxtaposed parallelepipeds masses floating over the site, the project offered pleasant exterior spaces at plaza level at the expense of the pavilion itself pushed underground (fig. 41). As a consequence, the jury rejected the scheme as weakening the Canadian identity and presence in Osaka. Lacking detailed information, the bold and dramatic mega-sculpture also presented risks of structural stability, as well as feasibility, noise and nuisance problems<sup>[233]</sup>.

Indicative of the reduction of commissions in 1967, Dimitri undertook a private project for the Carlo Della Valle Residence, Alassio, Italy, 1967-68<sup>[234]</sup>. Located in a bay of the Italian Riviera, it consisted of a large terraced house for an Italian engineer to be built on a sloping site facing the Ligurian Sea. Provided with greenhouse, water tower, longitudinal terraces and retaining walls, the site was already occupied by a “casa vecchia” to be demolished<sup>[235]</sup>. Of stone masonry and concrete, the new house presented a widespread juxtaposition of stepped rectangular terraced roofs with small stairs circumscribing a frontal opened courtyard (fig 42). Containing a multiplicity of rooms interconnected by many interior stairs on two floors, the jig-saw composition culminated with a towering maid’s room at the

front<sup>[236]</sup>. This project was interrupted at the preliminary drawings stage in January 1968.

Soon after, more staff reduction took place at ARCOP and the office was relocated to 1440 Ste-Catherine West<sup>[237]</sup>. While Desbarats kept a part time office there until the end of 1969, the name of the firm was eventually changed to Affleck Dimakopoulos Lebensold Architects (ADL). Few new commissions came in, such as the Life Sciences Building, University of Dalhousie, Nova Scotia, 1968-73, carried out by ADL<sup>[238]</sup>. This project was headed by Ray Affleck, assisted by Arthur Nichol, Project Architect, and Eva Vecsei, Project Designer, while Dimitri remained largely uninvolved<sup>[239]</sup>.

It was followed by the commission for the Complexe Scientifique, Ste-Foy, Québec, awarded to a consortium including the Quebec firm of Gauthier Guité Roy as well as ADL, of which Dimitri was the Partner-in-Charge of Design from Late 1968 to August 1969<sup>[240]</sup>. The client was the Provincial Government and the program featured a technical services office and laboratory complex. Uninvolved in later contract documentation and construction stages, Dimitri designed a large multi-phase project of which only the first phase was built<sup>[241]</sup>. It featured four identical three-storey blocks juxtaposed with central court. Each was set on rectangular plan with central laboratories and opened areas delimited by peripheral offices. Displaying a combination of protruding concrete piers and staircases alternating with modulated bays of vertical zigzag profile, the typical elevations featured angular window strips with vertically ribbed metal siding fascias. As for the exposed concrete surfaces, they presented an aesthetic treatment of linear relief texture set horizontally and diagonally (fig. 43)<sup>[242]</sup>.

As early as the mid-1960s, ADDLS was also commissioned to participate



in the City of Calgary Centre Development Study. Very much involved, Dimitri contributed to a masterplan including innovative concepts for the city core, working in collaboration with the City of Calgary urban planners<sup>[243]</sup>. Among others, the +15 pedestrian systems were developed featuring air rights for protected pedestrian walkways crossing over the downtown streets and linking large building structures to be equipped with elevated central plazas. At ground level, a ring system would serve the vehicular circulation network. This urban design study won a Massey Award in 1972<sup>[244]</sup>.

The Collège Montis Regii project, Université de Montréal, 1969, by ADL, was another design commission carried out by Dimitri as Partner-in-Charge, and Willy Sung as Project Designer<sup>[245]</sup>. Displaying a sensitive manipulation of contrasting horizontal balcony spaces and vertical shaft volumes, the lyrically articulated building took advantage of the Mount Royal campus' sloping site. The four-storey building, concealing an inner court opening to the north, stepped down one storey. It displayed four residential modules with zigzag perimeter facing the U of M Engineering Building and Central Pavilion to the south (fig. 44). Offering a spectacular view, these living accommodations were supported by high concrete ramparts setting dramatically the building off the edge of the hill<sup>[246]</sup>. Remaining unbuilt, the project won a Canadian Architect 1969 Yearbook Award.

The Le Concorde-Québec Hotel, Quebec City, 1969-74, was another project started in 1969 by ADL with William Tabler as Hotel Consultant<sup>[247]</sup>. While Norman Nerenberg was the Project Manager for Concordia Estates Ltd., Dimitri acted as Partner-in-Charge for ADL, assisted by Hans Stenman as Project Architect and Willy Sung as main Design Architect<sup>[248]</sup>. Facing Place Montcalm Square, the 120'x 260' site bordered the Grande Allée and

overlooked the Champs de Bataille, the Saint-Lawrence River and the Old City. Housing numerous convention facilities including parking, ballroom, four convention rooms convertible into one large space, shopping, recreational and administrative facilities, the 29-storey luxury hotel of 440 rooms also included three restaurants and two cocktail lounges, one of each being accessible by an exterior elevator<sup>[249]</sup>.

With a podium compatible to the residential scale and pedestrian surroundings, the building featured a rectangular notched slab topped by a revolving restaurant. Its main façades displayed staggered modules of four juxtaposed windows complemented by exposed precast concrete panels. The main structure of the hotel tower consisted in two longitudinal steel diagrids spaced 65'-0" apart, resting on ten supports and cantilevering 90'-0" over the conference centre and ballroom found on the lower floors<sup>[250]</sup>. Started by ADL, the project was eventually redesigned by Dimitri Dimakopoulos and Associates with a conventional concrete structure as we will see later. Construction started only in July 1972<sup>[251]</sup>.

Another project developed in the late 1960s by Concordia Estates Ltd. was Project West, a large complex to be located between Place Bonaventure and Château Champlain on the "Cardinal's Site", later occupied by Le 1000 de La Gauchetière tower<sup>[252]</sup>. While still with ARCOP, Dimitri, assisted by Willy Sung as Design Assistant, worked on several schemes. The reason for these alternatives was not architectural but the changing programs and directives originating from the client<sup>[253]</sup>. Until 1973, numerous studies were made for that site which development rights were controlled by Concordia. However, none of them became a reality.

A third project developed in the late 1960s by Concordia Estates Ltd.

was Cité Concordia, a major private urban renewal redevelopment project for the Milton Park area in Montreal<sup>[254]</sup>. Following a first scheme elaborated by Harry Mayerowitz featuring several long linear blocks located in a landscaped area, a second concept was evolved by ARCOP in 1969-70, with Affleck as Partner-in-Charge, assisted by his associate Ramesh Koshla (b.1934) and a group of younger graduates<sup>[255]</sup>. Inspired by Scandinavian precedents, their proposal featured a group of medium rise buildings attempting to reach the same average population density per city block as a single highrise building. Their proposal turned out to be a dull scheme, and the low volume buildings did not offer the density required by the developer<sup>[256]</sup>. Their master plan anticipated three construction phases and the existing housing in the first phase area was soon put to demolition. A bad atmosphere resulted due to the constant pressures against the project by a Milton Park group of citizens<sup>[257]</sup>. Backed up by the McGill community, they strongly orchestrated the public opinion in disfavour of the project's realization. While the conflict grew between his clients and "that section of the community most directly affected", Ray Affleck became very disillusioned with the project<sup>[258]</sup>.

The growing opposition forces, including the McGill students, teachers and people from the Milton Park community, generated a "general malaise" at the office. The position of his wife teaching sociology at McGill, as well as other of her colleagues, finally brought Affleck's controversial decision to resign from the \$250 million commission in July 1970<sup>[259]</sup>. As a result, the project was left in a critical state while claims and legal repercussions were foreseen if it had been completely dropped by ARCOP<sup>[260]</sup>. Since Concordia was the most important and steady client, the atmosphere grew dramatically

tense between Affleck and Dimitri who diverged in opinion on the attitude to adopt. Considering the project opponents as a minority, Dimitri believed in the feasibility and desirability of the new development as long as a mixed development was made available to all levels of income<sup>[261]</sup>. For more pragmatic reasons, Fred Lebensold was also prepared to take over the leadership of the project, proposing a “Lebensold and Dimakopoulos” partnership to Dimitri who proudly refused<sup>[262]</sup>. With the acceptance of the Concordia Group, the latter was finally able to retain the project under his own name and Lebensold consequently withdrew from it.

Dimitri’s break-up with ARCOP in late 1969 proved to be dramatic, involving strong feelings of anger and hurt from a self-made, proud and intelligent man<sup>[263]</sup>. Honest and intransigent, he would not compromise with ethics. Seeking advice, he met several times with Guy Desbarats who provided him with moral support in a period that brought them closer together. Finalizing the last agreements to dissolve ARCOP, Affleck and Lebensold negotiated with Dimitri and Desbarats the creation of “Arcop Associates”, a mistake leading the latter firm’s owners to appropriate most credits, publicity and successorship from the former partnership<sup>[264]</sup>.

Leaving ARCOP in December 1969, Dimitri proceeded with the set-up of his own independent practice. Hans Stenman and Eva Vecsei left with him, the latter on a part-time basis until spring 1970<sup>[265]</sup>. Although he excelled in architectural design and artistic draughtmanship, Dimitri would have to learn to accept the more mundane and unenjoyable aspects of his profession. Since it was his sole commission, he initially operated his entire practice from the Cité Concordia project office situated at 3633 Park Avenue. This proved to be his one and only office until January 1971<sup>[266]</sup>.

## PART THREE - DIMITRI DIMAKOPOULOS & PARTNERS (1970-1995)

### THE SEVENTIES

During the course of 1970, Dimitri spent approximately three quarters of his working time on the elaboration of a third concept for Cité Concordia. The remaining time was exclusively allocated for the design of other Concordia projects<sup>[1]</sup>. No projects for other clients were done on Park Avenue, and, at its peak in mid-1970, Dimitri's new office employed approximately fifteen people working primarily on Cité Concordia. While Dimitri acted as Partner of Record, Eva Vecsei was the Associate in charge of design for the "plan d'ensemble", working with him during all the subsequent design development stages<sup>[2]</sup>. Simultaneously, Hans Stenman acted as Project Architect, responsible for technical details and general coordination, and Willy Sung, who had left ARCOP later in the year to join Dimitri's office, became the design developer for the commercial infrastructure and lower levels<sup>[3]</sup>.

The 25-acre Cité Concordia urban redevelopment project was planned to separate the pedestrian flow from vehicular traffic through two pedestrian systems, one weather-protected, the other not, at surface level and forming part of the open spaces, gardens and squares<sup>[4]</sup>. Located at the intersection of Park Avenue and Prince Arthur Street, the first phase of the mega-project for 7000 inhabitants featured three adjacent L-shaped residential blocks complemented by a fourth commercial independent one<sup>[5]</sup>. The architectural concepts for the three residential blocks featured clusters of lowrise buildings complementing a highrise terraced apartment structure in each block

and wrapping around their respective inner squares<sup>[6]</sup>. The fourth block included an elongated Z-shaped 500-room hotel and a 29-storey glazed, round-cornered and twin-towered medical-office building (fig. 45). Both were placed next to each other along Park Avenue, the latter defining a large open public space called “L’Esplanade”. Located at the heart of the surface pedestrian network, it was intended for outdoor spontaneous and programmed activities, defining a centralized community meeting-place<sup>[7]</sup>. The project also involved the preservation of row houses on Hutchison Street as well as two churches on Jeanne Mance Street<sup>[8]</sup>.

Articulated around “L’Esplanade”, the Cité Concordia complex involved the closure of Prince Arthur Street between Park and Jeanne Mance. The sophisticated commercial infrastructure, allowing window-shopping from the street level and an enclosed promenade five feet below, included a shopping mall with a split-level section relating to “L’Esplanade” as well as a large underground parking garage<sup>[9]</sup>. Its name derived from places of assembly in Ancient Greece, “L’Agora” was the sunken retail component of the complex comprising more than one hundred stores, a market-place and a Park Avenue exterior shopping promenade<sup>[10]</sup>. “L’Agora” opened on “L’Esplanade” from which the natural light entered through a glazed gallery.

The Cité Concordia project was a constantly evolving exercise and different proposals were developed with changing emphasis on specific project components as the current economic conditions changed<sup>[11]</sup>. By the end of Spring 1970, a large sumptuous promotional brochure with multiple color drawings was published by the developers. Covering the centre section of the southerly four blocks of the overall six-block 25-acre site scheduled for a ten-year development, the construction of the \$65 million Phase One was

due to start later in the year<sup>[12]</sup>. Dimitri was particularly encouraged when the Montreal newspapers announced that the Provincial Government would contribute to some of the funding through means of subsidized housing. Unfortunately, due to the 1970 FLQ October Crisis, the postponement of the government promises and the subsequent financial constraints encountered by the client, the construction project was delayed indefinitely<sup>[13]</sup>.

From 1971 onwards, Dimitri pursued his involvement with the project. His final proposal, including a very detailed “plan d’ensemble”, was ultimately rejected by the City of Montreal which revoked its former agreement to have Prince Arthur Street closed to vehicular traffic<sup>[14]</sup>. The “Agora” and “Esplanade” concepts required the closure of this main east-west vehicular artery, and without that closure, the fundamental “raison d’être” for the urban design of Cité Concordia had become invalidated. Deceived, Dimitri did not want to give up his concepts. In the mean-time, he had become busier with the Université du Québec à Montréal (UQAM) project initiated in mid-1971 with an elaborate site study developed by the David Boulva Dimakopoulos consortium<sup>[15]</sup>.

All these factors resulted in his resignation from the Cité Concordia project in mid-1973. With Dimitri’s agreement, Eva Vecsei offered to Concordia City Properties Ltd. to continue the project and make a fourth proposal<sup>[16]</sup>. By the end of November, she had left Dimitri Dimakopoulos & Partners to pursue the project independently as the new Architect of Record, working at her own new La Cité Project Office<sup>[17]</sup>. Involving the redesign of a similar project on four isolated blocks separated by continuous streets, the final design was elaborated in the following months. The contract documentation and construction supervision of La Cité were carried out in associa-

tion with Dobush Stewart Longpré Marchand Goudreau Architectes<sup>[18]</sup>. Completed in 1977, the building was far from Dimitri's original concept<sup>[19]</sup>.

Having decided to leave ARCOP after five years, David Wigglesworth (b.1937) joined Dimitri's office on Park Avenue in November 1970, working for the next few months on the design development of a second bold and imaginative steel diagrid concept for the Le Concorde-Québec Hotel<sup>[20]</sup>. Although this scheme would have resulted in a spectacular architectural design integrated to a brilliant structural concept, Concordia ultimately produced estimates showing greater economy with a conventional concrete structure<sup>[21]</sup>.

Project West was the third active Concordia project under study on Park Avenue. Purely speculative, various design alternatives were investigated while the project had no formal name, being generally referred as the West Block Development<sup>[22]</sup>. In contrast to Cité Concordia, the two other projects were developed on a discontinuous basis and they were not Dimitri's client's immediate priority.

In January 1971, Dimitri set up another small independent office in the Dominion Square Building for approximately six months<sup>[23]</sup>. This was due to a new mandate from Marathon Realities for the design of a new Canadian Pacific Headquarters to be located on the former Laurentian Hotel site<sup>[24]</sup>. Following a multiplicity of massing schemes evolved by the famous American architect Minoru Yamasaki (1912-76), Dimitri Dimakopoulos & Partners proposed an elaborate project featuring a building complex including a main office tower, YMCA, daycare centre and plaza with skating rink, offering many social inputs in a properly integrated approach<sup>[25]</sup>.

Supervised by Dimitri, the small team included Christopher Adams, a



young urban designer, and David Wigglesworth, the Project Architect. Uninterested in urban design and social inputs, the CP Administrators rejected Dimitri's project during the main presentation, firing their own Project Manager the next day<sup>[26]</sup>.

On July 19, 1971, Dimitri's last change of address was to set up his own permanent office adjacent to the new David Boulva Dimakopoulos consortium project office, on the 5th floor of 1253 McGill College<sup>[27]</sup>. These offices were respectively located at Suite 500 and 570<sup>[28]</sup>. While Jacques Lefavre David (b.1921) and Pierre Boulva (1920-1991) had already established their own office on the 8th floor, the purpose of the three principals was to share a common working space for the Federal Department of Public Works Accommodation Programme Phase III, a gigantic office complex project for the National Capital to be located in Hull, later known as Place du Portage Phase III<sup>[29]</sup>. At the same time, the consortium was given the mandate to prepare a site study for the new UQAM University downtown campus<sup>[30]</sup>.

The Concorde West project was developed into its final third design version on McGill College between mid-1971 and 73. Eva Vecsei took over the design development from Willy Sung<sup>[31]</sup>. Dimitri's \$75 million project featured twin triangular towers, one being a 35-storey office tower, the other a \$40 million, 50-storey, 952-room luxury hotel to be managed by the New York firm Loews Hotels<sup>[32]</sup>. Both were linked together with a towering cylindrical shaft equipped with twin panoramic elevators leading to a revolving restaurant at the top<sup>[33]</sup> (fig. 46). The unusual triangular shape and careful orientation of the buildings provided unobstructed panoramic views from all its windows towards the Saint-Lawrence River, the Mount-Royal,

the Adirondacks and the Green Mountains<sup>[34]</sup>.

Located on a 100,000 square foot site, the complex was linked to the Montreal major transportation networks including the underground pedestrian system. The infrastructure was equipped with an eight-level 1200-car underground parking garage and a four-level cinema, retail, ballroom and congress meeting rooms gallery<sup>[35]</sup>. Topped by a mezzanine, the hotel and office lobbies including a banking hall opened on an exterior plaza providing an attractive entranceway to the complex from Dominion Square. Grouped around an interior garden covered by a glass dome supported by a space frame, various recreational facilities including cocktail bar, coffee shop, outdoor terrace café and two restaurants were accessible from ground level<sup>[36]</sup>.

At the first level above the hotel lobby were found eleven hospitality suites for 75 people, appropriate for private meetings. Above, the extra large hotel rooms equipped with wall-to-wall bay-windows offered wide panoramic views similar to those from the offices. On the open roof of the office building and accessible from both towers, another recreational center featured a year-round outdoor swimming pool with sun deck, gardens and bar as well as a health center on the level below<sup>[37]</sup>. Accessible from the two panoramic exterior elevators, the 300-person revolving restaurant was complemented by a 300-seat sky lounge immediately below, constituting a select place with exciting vistas<sup>[38]</sup>.

Much more elegant and articulated than the contemporary common slab skyscrapers, this early Late-Modernist design was an eloquent departure from Modern Functionalism, announcing future landmarks such as the Royal Bank Plaza, Toronto, 1971-77, by WZMH, and the Penzoil Plaza,

Houston, 1974-5, by Philip Johnson & John Burgee<sup>[39]</sup>.

By the end of 1972, the construction of the hotel-office complex was scheduled to start in 1973 to be completed before the 1976 Montreal Olympics<sup>[40]</sup>. However, the project never evolved further than the preliminary design and Concordia eventually lost its development rights on the site<sup>[41]</sup>.

Under Dimitri's supervision, the final design and construction drawings for the Le Concorde-Québec Hotel were made in 1972-73 in his own office, with the assistance of his two associates Eva Vecsei and Hans Stenman, respectively in charge of design and technology<sup>[42]</sup>. Located on an exceptional site with the Old Quebec City district in the background, the 30-storey tripartite slab featured a semi-pyramidal form derived from step-back zoning regulations to preserve the low scale of existing buildings on Grande Allée<sup>[43]</sup>. Combining precast concrete panels with cascading sections of ribbed metal siding, its bold, clean, uncluttered lines converged towards a cantilevering podium base matching street scale (fig. 47).

Through the manipulation of the structural mass and the originality of the volumetric design, the architectural local constraints were seized by Dimitri as an opportunity to fit the architectural urban context<sup>[44]</sup>. Resolutely Modernist and avant-garde, the building also concealed some regionalist concerns and echoed the vernacular architecture of Old Québec City's high pitched roof stone houses.

Displaying an unusual notched perimeter, the two longitudinal elevations offered an exciting pattern of horizontally elongated windows set within a straight orthogonal structural grid. Rhythmic alternance was emphasized by means of half-length dark metal panels set below the windows within the lower precast concrete panels. The overall design resulted in a

sophisticated architectural raper or piano like motif (fig. 48).

The powerful mass of the revolving restaurant, emerging from the flat roof, crowned the building, presenting a final set-back with its culminating mechanical penthouse. The first revolving restaurant in the province, it offered spectacular changing views of the Saint-Lawrence River, Quebec City and the Laurentians within a one-hour complete rotation<sup>[45]</sup>. In this final scheme, “L’Astral” was made accessible from one large panoramic elevator situated on the back longitudinal façade<sup>[46]</sup>.

The main entrance, which faced Place Montclam, featured an elegant canopy articulated in three sections and supported with stay cables to an integrated triangulated concrete structure. Displaying exposed concrete surfaces, mirror and light effects, the main lobby featured a fountain-sculpture representing a triple stage crystal stalactite suspended above the main stairwell leading to the lower levels<sup>[47]</sup>. From there, one could reach two restaurants, a café-terrasse, two bars, a nightclub and an heated exterior swimming pool. A total of eighteen meeting rooms accomodating up to 1200 people was also found in the hotel including a grand ballroom, seven salons and hospitality suites<sup>[48]</sup>. Finally, a two-storey underground parking garage occupied the basement levels with other ancillary service spaces.

Operated by Loew’s Hotels, the 450-room Le Concorde-Québec was scheduled to open in Spring 1974. The building construction was mostly completed on time. By the month of May, Hans Stenman had left the office to join Daniel E. Lazosky (b.1932) in a new partnership<sup>[49]</sup>.

Having won a short list competition between few major Canadian architectural firms, David Boulva Dimakopoulos was awarded the commission for Place du Portage Phase III from the Federal Government in mid-1971.

The commission was awarded after the announcement of a ten-year program (1971-81) for the construction of ten million square feet of Federal office space on the Quebec side of the National Capital<sup>[50]</sup>. The project followed the recommendations of the National Capital Commission and it was part of what would be later known as the Hull East Pole mega-complex (fig. 49)<sup>[51]</sup>.

Since no urban plan had been prepared for the new Hull downtown core, the firm Urbaplan, composed of the firms of Jean Issalys in Hull and Etienne Gaboury in Winnipeg, was commissioned by the NCC to produce an urban design study. Public Works Canada (DPW) simultaneously engaged David Boulva Dimakopoulos for a similar study<sup>[52]</sup>.

From their joint efforts emerged the principle of incorporating to Phase III an adjacent open public space to the west and a central major transportation node to the north, called respectively Place Aubry and Place d'Accueil. Similarly, an understreet T-shaped parking garage was foreseen immediately to the south, while inter-connected office space was established on both sides of Boulevard Maisonneuve<sup>[53]</sup>.

Assisted by Wigglesworth acting as Project Architect and Sung as Design Architect, Dimitri evolved a proposal which turned out to be very successful<sup>[54]</sup>. The early design studies revealed that the high density requested by the program resulted in massive volumetric weight totally out of urban scale. It needed to be countered through the break up of forms and masses. Careful attention was given to details in order to bring down the building to human scale and a converging diagonal orientation was adopted to reduce the frontal visual impact<sup>[55]</sup>. Made accessible from Ottawa by the Portage Bridge and spanning above vehicular traffic, the resulting design of the complex featured unequal masses located mainly to the East (fig. 50)<sup>[56]</sup>.

Designed to accommodate 5,400 civil servants working in the upper office floors, Phase III included a public concourse with commercial spaces<sup>[57]</sup>. Forming the major part of Place du Portage and establishing the point of arrival from Ottawa, the complex included conference rooms, cafeteria, computer center, atrium and public circulation systems<sup>[58]</sup>. The building received as much attention at urban design scale as at architectural design level.

Developing volumetry originating from the program, Dimitri designed a complex including six office towers in two unequal groups, stepping down from eighteen to nine storeys<sup>[59]</sup>. Four higher blocks were located to the east while two lower ones were located to the west. The main blocks were joined together with a three-storey bridge on three levels spanning above Maisonneuve Boulevard. Integrated harmoniously to the context by means of varying glass and concrete finishes, the six towers expressed their vertical circulation shafts by means of peripheral blind concrete towers sided by daylit elevator lobbies. The remaining elevations featured mainly glass in their continuous horizontal window strips and spandrel fascias, thereby diminishing the masses of the façades<sup>[60]</sup>. Stepping down in cascading form, the building infrastructure included a series of articulated base projections on four storeys facing Place d'Accueil (fig. 51). Pleasant and fragmented, it featured public and commercial interior spaces on two levels.

Highly sculptural, the overall Late Modern Formalist design was characteristic of the Dimakopoulos personal style at its best<sup>[61]</sup>. Attesting to his Mediterranean roots, it demonstrated his meticulous concerns for articulated details in resonance, syncopation of rhythms, forms and textures as well as admirable interplay of light and shade.

Engaged as Construction Manager by DPW in Spring 1973, Montreal's

Concordia Construction Ltd. became an effective member of the project management team headed by DPW, using a design-built procedure to accelerate the construction process and therefore reduce the costs. The \$88 million complex was finally occupied by May 1977<sup>[62]</sup>.

The largest government building of the 1970's built in the Capital, this grey megastructure dominated the view from the Parliament, resulting from an overt political act symbolizing the advantages of the Confederation (fig. 52)<sup>[63]</sup>. Although handled masterfully, the massiveness of these huge façades were condemned by many, their criticism being addressed mostly towards the government rather than the architects<sup>[64]</sup>.

This major commission was complemented by the \$8 million Place d'Accueil project, 1971-78, developed simultaneously into a multi-level transit interchange bisected by Maisonneuve Boulevard and bordered by Place du Centre<sup>[65]</sup>. In addition to that was the \$17 million Laurier-Taché Parking, 1971-75, the 1600-car underground parking garage on three levels located near the bridge access. Establishing the focal point of arrival in the Hull city core, Place d'Accueil was designed to accommodate all types of transportation including pedestrian, bus and automobile while underground planning provisions were made for future subway rapid transit<sup>[66]</sup>. At street level, direct access was provided by means of car and taxi drop-off curbs and parking garage entrances<sup>[67]</sup>.

The use of natural topography allowed the creation of two independent vehicular and pedestrian systems. Serving more than 15,000 people during weekday rush hour, the public transport transit platforms were designed on two levels separating vehicles from pedestrians and linking both sides of Boulevard Maisonneuve<sup>[68]</sup>. Providing an exterior and interior link between

the various public spaces of Place du Portage and Place du Centre, it extended into a multi-level complex of plazas with landscape terraces and fountains leading to Place Aubry and Rue Principale.

Located at the centre of the federal and provincial projects, Place d'Accueil interconnected all buildings in the mega-complex through complementary weather-protected malls and walkways leading towards Hôtel de Ville and Principale Streets and offering access to the different building levels. Seeking architectural integration of Place du Centre, Phase III and Place d'Accueil, the project comprised a series of base projections to keep it articulated and pleasant. Zigzag perimeters were used as well to integrate Place du Centre and to create a sensitive and continuous interface with Place d'Accueil. Well inter-related, both buildings featured in their respective bases powerful forward harmonizing movements<sup>[69]</sup>.

Although the Place d'Accueil won a Canadian Architect Honourable Mention in 1977, its original programmatic content was never fully followed by the Federal Government<sup>[70]</sup>. Because of financial cut-backs, the project lost many of its original features. The 1% budget for art was not totally spent and the original scheme for rentable retail space was finally abandoned<sup>[71]</sup>. Similarly, Place Aubry's fountains and waterfalls were only operated one year while the trees were later cut down.

On July 5, 1971, the commission for the UQAM University site study was awarded to Consultas Inc., including the architectural consortium of David Boulva Dimakopoulos<sup>[72]</sup>. While Dimitri acted as Partner-in-charge, he was soon joined by Fernand Magnan (b.1938) who became the Associate in charge of the programming<sup>[73]</sup>. Completed in October 1971, the site study consisted in selecting a site for the new campus located in part above the



Berry-de-Montigny Métro station<sup>[74]</sup>. The double mandate consisted in the survey of all properties on six adjacent blocks in order to proceed with expropriation and preservation. It also included a general concept for future ground use. Economical, urban and engineering studies were complemented in a preliminary program.

As a result, an elegant brochure was published including urban and site considerations, constraints, criterias and objectives as well as methodology studies resulting in evaluation charts for the final selection of three blocks from various optional combinations. The conclusion of the report recommended the selection of two adjacent sites facing Ste-Catherine Street complemented by a third adjacent one to the north-west, constituting an L-shaped campus to be developed in two phases. Heights of five, seven and eleven storeys, construction on three fourths of the site, inter-connected circulations, preservation and expansion recommendations were included<sup>[75]</sup>.

Preserving the Saint-Denis Street scale and character, the opened spaces of Place Pasteur and the Notre-Dame de Lourdes Church, the report identified the historical value of the Neo-Gothic Saint-Jacques Church spire, its southern transept garden and sacristy stained glass woodwork, all surviving from the 1933 fire<sup>[76]</sup>. While no general parking and student residences were foreseen on the campus, public pedestrian traffic and internal campus circulation were integrated into the same network<sup>[77]</sup>.

The first mandate was immediately followed by a second one for the UQAM University masterplan in Spring 1972. Produced by the same consortium and supervised by Dimitri during the rest of the year, it displayed an implacable logic in order to create a flexible, evolutive, permanent and popular university open to its urban context<sup>[78]</sup>. As a working instrument for

future design development, the masterplan established a volumetric envelope including phased spaces to be built within the next three years.

The masterplan transposed in terms of spaces and physical equipments the university policies relating to education, urban integration and renewal. Three superimposed layers of circulation were determined for public, mixed and limited access. Including more than 2.5 million square feet, the \$77 million complex was estimated in terms of dry and plumbed areas to be built in two phases<sup>[79]</sup>.

The height and massing of the buildings followed their immediate relationships with surrounding streets, generating a concave profile rising from St-Denis and Ste-Catherine Streets towards Berri Avenue and Dorchester Boulevard<sup>[80]</sup>. These two wider vehicular arteries were more compatible to high-rise construction than the two other pedestrian and commercially oriented streets<sup>[81]</sup>.

To be easily accessible from the street, the complex included 30% of open spaces as well as retail areas in order to maintain the existing commercial orientation. Para-academic activities were planned along the pedestrian walkway from the Métro. From the underground primary network to the upper mixed system, escalators were foreseen to accelerate pedestrian circulation, while elevators were selected for higher specialized areas<sup>[82]</sup>.

Following a display of optional schemes, the arts and letters departments were located in Block C, above the Métro station, along with a socio-cultural centre, retail stores, art gallery and specialized library. Twice as deep, Block E included the human, economical, administrative and juridical science departments, general administration and library, most of the food services and limited parking, as well as future expansion space near

Dorchester. Scheduled for the second phase to the west, Block B included the psychology, pedagogy and science departments, as well as a research center and sport's facilities. These departments were grouped together because of the need to juxtapose their wet laboratories and equipment<sup>[83]</sup>.

Sketches and graphics, scaled drawings and plexiglass display models, charts and narratives were produced by a small team in less than six months, and a second brochure was published before the end of the year<sup>[84]</sup>. Under the influence of Léo Dorais, rector, Dimitri decided later to pursue the design development with Jodoïn Lamarre Pratte rather than David & Boulva, the former being a younger French Canadian firm with a less commercial image and some political support<sup>[85]</sup>.

By December 1973, the project was further developed by Dimitri and Willy Sung, his design assistant, into an integrated “transparent” university opening on its urban context like a living organism<sup>[86]</sup>. Resuscitating the old Latin Quarter after thirty years, it intended to spread its academic dynamism into the social context<sup>[87]</sup>.

Earning a 1974 Canadian Architect Yearbook Award of Excellence, the UQAM Downtown Campus was perceived as a super-project of urban and architectural design answering a demanding program<sup>[88]</sup>. The mature scheme featured excellent conservation, exciting spaces and scale appropriate within the urban context. The presentation model displayed an elaborate development of building masses articulated around open spaces and including major conservation components.

Featuring a four-storey cultural “agora”, side-lit from transept windows as well as roof skylights, the “Grande Place” of the Saint-Jacques quadrilateral offered an exciting internal space extending from the surviving transept

stone façade into the nave of the converted church (fig. 53)<sup>[89]</sup>. As a grand central Agora, this open space was provided with surrounding socio-cultural activity spaces on two storeys at the subway level and its mezzanine.

By January 1975, the elevations were already resolved and a new model including detailed façades was unveiled with definitive design drawings (fig. 54)<sup>[90]</sup>. Scheduled to start in the Spring, the construction period was extended to July 1978. Reaffirming its original concerns for contextual openness, the UQAM administration encouraged its application with a campus opening directly on the mezzanine of the subway station. Anticipating the inauguration for September 1978, the project was perceived as the architectural materialization of a non-monumental extroverted concept for a progressive institution<sup>[91]</sup>.

Flexible and adaptable to academic modifications, the design offered multiple advantageous revolutionary concepts resulting in a pioneering project in architectural preservation and contextualist integration<sup>[92]</sup>. While the original proposal featured the inclusion of precast concrete elements, Dimitri was required to abandon them in favour of façades finished exclusively in brick (fig. 55)<sup>[93]</sup>. These unnecessary changes resulted in an extra economy of \$5 million in relationship to the overall budget. Similarly detrimental to the contextualist approach, the client's decision to remove the street retail store fronts resulted in a gain of usable internal office spaces<sup>[94]</sup>.

By March 1975, the excavation and foundation works were initiated following the partial demolition of the Saint-Jacques Church which generated a contestation from preservationist groups who criticized Dimitri's scheme<sup>[95]</sup>. While the construction of the infrastructure was sche-

duled to start in fall, the vast all-electric and air conditioned complex featured large fixed windows facing the surrounding streets and open green spaces, favouring generous penetration of natural lighting<sup>[96]</sup>. As for circulation ease and efficiency, pedestrian circulation was calculated at twelve minutes maximum between the most distant points of the campus.

By Spring 1977, the first phase was scheduled to open in September 1979. In order to keep the complex within budget, savings were achieved by leaving the ceiling mechanical ducts apparent and brightly colored and by putting just one large fixed window per classroom. Walled in only with painted concrete block walls, many classrooms were made adaptable to future changes<sup>[97]</sup>.

On September 15, 1979, ten years after its founding, the UQAM finally opened its new \$66 million downtown campus to receive 10,000 students representing 65% of the university's total population<sup>[98]</sup>. The inauguration ceremony of the two new pavilions, called respectively Pavillon Judith Jasmin (Block C) and Pavillon Hubert Aquin (Block E), featured a speech by Jacques-Yvan Morin, Quebec Minister of Education<sup>[99]</sup>. In May 1980, the new UQAM Campus won the Order of Architects of Quebec Award of Excellence as a remarkable application of the most advanced architectural theories in relation with heritage preservation<sup>[100]</sup>.

During the 1970's, Dimitri Dimakouloulos & Partners were also involved in a series of smaller projects<sup>[101]</sup>. The first one was the Winter Wondorlando project, Orlando, Florida, 1973. Owned by Fairbank Industries Ltd., Boston, and developed by Concordia Estates Ltd. in Montreal, this exotic project for a recreational centre offered ski and related winter activities to Florida residents and visitors within a large and compact

specially designed structure<sup>[102]</sup>. Dimitri was heavily involved in the project and spent 3 to 4 months supervising a team of three young graduates<sup>[103]</sup>.

Located on a large 355-acre site near the Walt Disney World entrance, this educational, recreational and entertainment complex contained cold weather activities such as Alpine skiing and sledding, skating, snowshoeing and snow playing, as well as a polar zoo and museum, an Arctic flower garden, a Santa's Village, a cinema and complementary stores and dining areas<sup>[104]</sup>. The unusual programmatic requirements for this winter pleasure palace generated a highly original scheme. Grouping activities by required temperatures, the 300-foot building offered a compact volume with a sloped roof, featuring mainly an exposed 500-foot-long tubular and curved ski run with a fall of 130 feet leading to a level 25 feet below grade (fig.56)<sup>[105]</sup>.

Stacked activities ranging from cold to cool and warm temperatures at the top were planned within the building, while earth was compacted around the structure to act as insulation for the colder areas. Connected to an artificial waterway system and accessible by boat, the complex included snow making facilities. The project won a 1974 Canadian Architect Year-book Award of Excellence, but unfortunately it was never built<sup>[106]</sup>.

Originating from Greece, another commission was given by a private developer associated with a Canadian partner<sup>[107]</sup>. The Porto Carras project, Sithonia, Greece, 1975, consisted of a small convention centre with landscaped parking facilities. Displaying a flat roof with peripheral sloping canopy, the one-storey quasi-rectangular structure featured a large roof skylight and trapezoidal entrance tower<sup>[108]</sup>. Dimitri visited the site in early 1975 and subsequently worked two months on the project with the assistance of Willy Sung<sup>[109]</sup>. Schematic plans and model were developed,

but the project remained unbuilt.

The La Citière Housing Development, Laprairie, 1975-78, was a project developed by Dimitri Dimakopoulos & Partners in the mid-1970's for Gulf Development of Laprairie Inc<sup>[110]</sup>. While Dimitri was mostly uninvolved, Fernand Magnan managed the project independently, starting with an urban plan including industrial and residential parks. 200 units of medium density housing were built on the banks of a new 24-acre lake, with views on the Saint-Lawrence River and Montreal<sup>[111]</sup>.

Managed and coordinated by Herbert C. Auerbach, the Saint James Street Development Study, Montreal, 1975-76, was a mandate given by the Association of Saint James Street Property Owners. It involved an urban design study and architectural project. Dealing with urban revitalization, it included a building survey and economical analysis of aging commercial structures, followed by some management, renovation and demolition recommendations.

Dimitri, assisted by David Wigglesworth, developed some preliminary concepts for street plantations and accessories, walkways and pedestrian skyway bridges. A renovation and expansion project was also evolved for the London and Lancashire Building, 244 Saint James Street West, 1898-99, by Edward Maxwell (1867-1923)<sup>[112]</sup>. Requiring restoration, this 7-storey historical landmark in the Beaux-Arts style was complemented by a proposed contiguous 8-storey office building facing Notre Dame Street<sup>[113]</sup>. Losing its rear façade, the existing building featured upgraded interiors for contemporary use. Placed back to back, both structures would open on each other at every floor level, sharing new centrally located stairwells and elevators built in the new addition<sup>[114]</sup>.

Twice as wide and more spacious, the proposed building had a façade lined up with that of the existing building on Saint-Jean Street<sup>[115]</sup>. On the upper levels, the former featured six rhythmically modulated strips of precast concrete panels with vertical fins and windows (fig. 57). Similarly, three double-storey glazed bays were set between precast concrete pilasters at ground level. Harmonizing with the existing façade, the proposed elevation displayed a narrow vertical strip of blind concrete recessing backwards and providing a proper interface connection. Completed in January 1976, the preliminary study was never implemented<sup>[116]</sup>.

In early 1976, a commission for organizing a Greek Exhibition at Terre des Hommes during the 1976 Montreal Olympic Games was awarded to Dimitri Dimakopoulos & Partners by the Government of Greece<sup>[117]</sup>. Focusing on the theme of Olympia and the origin of the Games, the exhibition was held all summer at the former Expo 67 Belgium Pavilion, converted for the occasion into the Greek Pavilion. Special moulds were prepared for sculptures from Olympia and the National Archaeological Museum of Athens. A thematic transition between Antique, Byzantine, Post-Byzantine and Contemporary Greece was also conceived by exhibiting costumes, jewelry and other artifacts in other sections of the exhibition. On the first floor, the Greek Pavilion offered contemporary popular Greek music and dances to the visitors<sup>[118]</sup>.

Coordinated by the Embassy of Greece and the Greek Trade Commissioner Constantine Haratsaris, the entire project was designed by Dimitri himself with the coordinating assistance of David Wigglesworth and Laurent Marquart (b.1937) from Jacques Guillon Designers Inc., responsible for the graphic and industrial design features. Very much involved, Dimitri



went to Greece for a few days and travelled in the country to select reproductions of famous sculptures and other artifacts. Recognized by Greek authorities as the best Greek architect in Montreal to represent them, Dimitri displayed the same enthusiasm and authority in both countries to carry out this task<sup>[119]</sup>.

The Terre des Hommes project was followed by the Action 77 Lachine Canal special project, Montreal, 1977-78, consisting mainly in the preparation of a masterplan for an 8.7-mile linear park along the waterway<sup>[120]</sup>. It sought to open sections of the canal to small boats, transforming the banks into parkland and introducing a network of recreational and bicycle trails<sup>[121]</sup>. For the first phase of 1978, old railroad cabooses were installed at a few strategic points to be used as information booths and washrooms. While his office brought in a consultation team to produce the masterplan and coordinate the project, Dimitri was never much personally involved in this 2-year project. Since there was little budget for architectural design, Dimitri relied on Wigglesworth to provide the coordination between DPW, the CPR and the City of Montreal<sup>[122]</sup>.

By mid-1978, the first major architectural competition organized by the new Quebec Provincial Government was launched<sup>[123]</sup>. Following the Order of Architects of Quebec recommendation, the architectural team selection process for the future Palais des Congrès de Montréal attracted 27 candidates. As part of a consortium, Dimitri's firm was selected with four other groups to produce a project. Totally involved in the design process, Dimitri was assisted by Sung and the rest of the office to produce the competition drawings in a relatively short period of time<sup>[124]</sup>.

Straddling the Ville-Marie Expressway, the \$60 million complex was

located in the quadrilateral defined by Saint Antoine, de Bleury, Vitré and Saint Laurent Streets. Dimitri's project consisted mainly in a two-storey rectangular building topped by an orthogonal grid of exposed structural roof beams (fig. 58). Complemented by smaller and lower terraced volumes extending to the south and to the west, it featured a straight ramp system running from de Bleury Street, two streets to the west, and leading to the upper large opened spaces of the congress centre. To the north, on de La Gauchetière Street, a pedestrian mall led to an opened landscape plaza facing an elaborate play of terraces, access stairs and ramps spanning over Vitré Street towards the main building<sup>[125]</sup>.

Presided over by the judge Lucien Tremblay, a jury of ten members proceeded to analyse the five finalists' projects including the design of Dimakopoulos Magnan & Associés<sup>[126]</sup>. In September 1978, the jury made its final choice in selecting the project signed by Jean Ouellet (b.1922), a decision which generated heated protestation from the four other finalists who requested disqualification<sup>[127]</sup>. The reason was that the winning scheme did not respect the rules of the competition relating to cantilever restrictions above Vitré Street.

With all their major projects mostly completed, Dimitri and his two partners were desperately in need of a new large commission (fig. 59)<sup>[128]</sup>. A second chance came up with the Palais de Justice de Québec Competition launched by the Quebec Provincial Government in the spring of 1979<sup>[129]</sup>. Organized by the Ministère des Travaux Publics et de l'Approvisionnement, the competition followed two stages, the first to select the participants, the second to select the winning project<sup>[130]</sup>.

The architectural consortium of Dimakopoulos Magnan & Associés of

Montreal, Chabot Gilbert Jarnuskiewicz Mainguy from Quebec City, and Larose Laliberté Petrucci from Montreal having been selected to participate, Dimitri proceeded with the conceptual work in early June<sup>[131]</sup>. Brain storming sessions were held at his office with key players such as Dimitri, Willy Sung, Gilles Chabot and David Wigglesworth, while Gilles-L. Larose (b.1920) worked on the interior planning of the courtrooms, area adjustments and estimates<sup>[132]</sup>. Determined to win, Dimitri supervised the design and project administration with Gilles Larose. He was mainly assisted by Sung for the design and by Wigglesworth for the project management.

Working seven days a week for more than two months, the team followed a standard design process<sup>[133]</sup>. The first week was spent in research, collecting information on other courthouses and their functioning through readings, visits and interviews with lawyers. Gathering data and analysing the very strict program, they visited the site, inspecting the physical, legal and budgetary constraints. The triangular site, bordered by an elevated highway and surrounded by old historical buildings proved to be very difficult from an environmental and sub-soil structural point of view<sup>[134]</sup>.

Serving the district of Quebec City and incorporating civil, criminal and juvenile courts, the building required three independent pedestrian circulation networks, namely the public, the private and the custodial security systems<sup>[135]</sup>. Through a process of conversing, scribbling and drawing, the team developed a dozen options<sup>[136]</sup>. Generated by the site and accommodating the three circulation systems, an atrium concept was brought in to offer proper functional distribution of the peripheral spaces<sup>[137]</sup>.

The next development stage consisted in the analysis and evaluation of each option. This led to the selection of the best solution offering the grea-

test coherence and logic. Finalized in one evening, the architectural concept was put into three dimensions by Sung who later brought to the office a small cardboard model including all ingredients<sup>[138]</sup>. Feeling confident that they had the best solution, the team worked at the elaboration of a great piece of architecture.

The interior planning was further developed around a large rectangular glazed atrium rising on four levels with reflecting pools, cascades and greenery. Adorned by sculptures and other works of art, it would provide a central focus to the organization of the interior spaces<sup>[139]</sup>. The main entrance led to the four-storey atrium around which superposed walkways led to the various courts. Panoramic elevators, suspended stairs and Quebec's grey granite floor slabs would give serenity and nobility to this majestic interior space<sup>[140]</sup>.

Static and monumental, the front east façade was designed for pedestrians while the articulated and dynamic volumetry of the rear part visible from the highway was derived from the atrium roof (fig. 60). Located on the new Jean Lesage Boulevard, the main entrance was complemented by three secondary accesses. Along the main façade, a covered gallery extending into lateral walkways planted with trees led to a small stepped public plaza with water basin to the south<sup>[141]</sup>. On the north side, the exterior landscaping adjacent to the building included a multi-level fountain-basin (fig. 61)<sup>[142]</sup>.

Oxidized copper was selected for roof parapets, window mullions and panelling of exterior elevator cores, while green reflective glass curtain-walls and greenish slate veneer would complement the precast and poured concrete elements<sup>[143]</sup>. The combination of these materials gave to the building remarkable aesthetic qualities, offering verdigris tints in harmony with

the built environment.

The six storey building featured a total area of 50,400 square meters including a 91-car interior parking in the basement. Introverted by nature and displaying a distinct architectural signature, the building design offered civic pride and monumentality, carrying special public significance. Easily recognizable, it offered contextualist integration by means of materials and colors, displaying environmental and human concerns<sup>[144]</sup>.

By July 25, 1979, the final competition drawings were started by an enlarged team of ten people<sup>[145]</sup>. During the last two weeks before the deadline, a set of more than 14 architectural plates drawn in China ink were prepared, including perspectives, site and floor plans, circulation diagrams, elevations and sections<sup>[146]</sup>. The final complete document including architectural and engineering reports and plates was submitted on August 8, 1979, the last day of the competition<sup>[147]</sup>.

The jury of twelve, presided over by Jean Ouellet, evaluated the five projects submitted, basing their decision on architectural and aesthetic qualities, environmental integration, Québécois content, respect of technical requirements, ease of maintenance and operation, energy conservation, time schedule and cost control<sup>[148]</sup>. According to the jury, Dimitri's project offered the best synthesis of an excellent architectural scheme answering all the program requirements. Clearly articulated, the interior planning answered remarkably well the complex functions of the building. All interior spaces were well studied and the atrium unified the miscellaneous functions favouring an easy identification<sup>[149]</sup>. On August 29, 1979, the Ministerial Cabinet ratified the selection recommended by the jury<sup>[150]</sup>.

Dimitri was extremely pleased by the results and very proud of earning

such an important commission through competition procedures rather than political patronage, insuring work for his firm for the next four years (fig. 62)<sup>[151]</sup>. For one full year and until August 1980, his winning team developed carefully the working drawings and specifications<sup>[152]</sup>.

Following a three-year schedule, the \$54.4 million (1983) construction project was subdivided into seven contract packages awarded following a standard call for tenders process<sup>[153]</sup>. Started on August 28, 1980, the excavation, compaction and embankment works were completed in December 1980<sup>[154]</sup>. Structural works were started on October 23, 1981, followed by the atrium roof installation in the summer of 1982. By mid-1983, the exterior shell of the courthouse was in place (fig. 63)<sup>[155]</sup>. Soon later, the atrium was fully equipped with artworks and accessories (fig. 64). The building was completed on time and budget before the end of the year.

On September 29, 1983, 600 bureaucrats, judges, lawyers and professionals were moving into the new facility<sup>[156]</sup>. The official inauguration of the building was led by Alain Marcoux (b.1945), Minister of Public Works and Supplies, on October 23, 1983, and the 1000 workers who contributed to the construction were invited with their families to the ceremony<sup>[157]</sup>.

At the turn of the decade, Dimitri Dimakopoulos & Partners also became involved in projects of secondary importance including the Hellenic Community Center, Montreal, 1979-82, the Freiman Mall and La Baie, Ottawa, 1979-1983, and the Taikoo Shing Site "B" project, Hong Kong, 1980-81<sup>[158]</sup>. Located at 5757 Wilderton Avenue, behind the Greek Orthodox Cathedral, the \$5 million Hellenic Community Centre featured a low widespread building with high one-storey convention room and gymnasium wings on both sides of a main front entrance. Further at the back was

found a three-storey wing for a primary school and community offices<sup>[159]</sup>.

Since the Cathedral was very precious to him, Dimitri was very concerned with the design of a respectful and well integrated structure. Wrapping up the back of the Cathedral zone and harmonizing with its forms, elevations, materials and textures, the auxiliary building would display flat roofs, orthogonal and angular corners, mid-brown brick and metal siding<sup>[160]</sup>. Highly contextualized, Dimitri's Late Modernist and very subdued design preserved the importance and character of the Cathedral as the original dominant structure on the site. Following the conceptualization stage, Wigglesworth took over the contract documentation. Construction started on November 1st 1981 and by September 1st, 1982, the building was completed.

The Freiman Mall in Ottawa featured a \$20 million commercial complex project for La Baie linking the new Rideau Center on Rideau Street to the Byward Market on Saint-George Street<sup>[161]</sup>. The project included the partial renovation and opening of the existing La Baie Store to the west, the conversion of Freiman Street into a covered pedestrian mall, the extension of the same store to the east and two complementary pedestrian aerial bridges linking the Rideau Centre to the north<sup>[162]</sup>. La Baie Store was opened up in order to allow direct access from the mall into the three primary levels. Demanding a more inventive design solution than a standard shopping center, the Freiman Mall offered greater architectural challenge. It was closely integrated to the new Rideau Mall, 1979-83, by Sankey Associates <sup>[163]</sup>. Dimitri and Sung were much involved in the early stage of the design, as was Andrea Wolf (b.1953) who also played an important role in the design development, while Wigglesworth acted as Project Architect<sup>[164]</sup>.

Featuring a multi-level opened space lobby on Rideau Street with criss-crossing stairs and escalators, the mall extended into a three-storey linear space covered with a sloping continuous glazed roof. Articulated with surviving parts of the classicizing former west façade, ground floor bay-windows, exposed roof truss and columns, the mall included ornamental trees with circular floor grills, continuous plantation boxes zigzagging along the walkway and stepped curbs for sitting and relaxing. Featuring two superposed mezzanines with glazed guardrails, the eastern face displayed a series of circular columns covered by polished panels protruding from the mezzanine fascias finished in a similar manner (fig. 65). The Rideau Mall was later dismantled in the 1980's, and the La Baie Store was subsequently expanded into the Freiman Mall causing the loss of much of its original character to Dimitri's disappointment<sup>[165]</sup>.

## THE EIGHTIES AND NINETIES

Hired in 1980 as Design Consultants by Wong & Tung, a large Hong Kong architectural firm, Dimitri and Willy Sung became very involved in the design of the \$150 million multi-functional commercial complex called Taikoo Shing Site "B"<sup>[166]</sup>. This project was initiated to recuperate development land occupied by dry docks situated in the Hong Kong commercial downtown district on the Kowloon Bay coastline. Seeking to maximize the land use in a very dense urban development scheme including a dozen future towers on both sides, Dimitri and Sung developed a large complex of extremely high density<sup>[167]</sup>.

Their very powerful design featured an X-shaped structure bordered



by two future side towers. Allowing a wide expanse of peripheral mirror glass walls, two V-shaped office towers rose up 23 storeys on each side, linked by a central pedestrian bridge at the top (fig. 66). The bold symmetrical design displayed an 8-storey central retail area with roof terrace, linear glazed roof atrium on transversal axis, roof skylights and glazed roof entrances<sup>[168]</sup>. Although very well received and approved by Wong & Tung, the project was later cancelled by the client due to major programmatic changes.

In 1980, Dimitri's firm also entered the Boumediene Tower Open International Architectural Competition held by the Algerian Government, and won the first prize<sup>[169]</sup>. For this \$10 million project, Dimitri Dimakopoulos & Partners acted as design architects for the large Montreal engineering firm Lavalin Inc. headed by Bernard Lamarre (b.1931) who submitted a turn-key contract proposal<sup>[170]</sup>. Selected from all other entries, their winning design proposed a specific location on a hill which was part of a masterplan for the recreation and zoological gardens of Algiers<sup>[171]</sup>.

At ground level, the main entrance, set in a reflecting pool with three fountains, contained tourist services and access to the two exterior panoramic elevators. The upper levels of the concrete structure were designed to accommodate a kitchen and rotating restaurant, interior and exterior observation decks offering spectacular panoramic views of the city below, and a telecommunication station, culminating with a 53-meter antenna in three sections<sup>[172]</sup>. The tower shaft was vertically split in two, the central gap allowing the course of the two elevators. Highly sculptural, the tower designed in five sections presented a spreading base curving gently into a bisected hexagonal shaft braced at three levels. The 5-storey capital featured cantile-

vered and superposed rings recessing at kitchen and telecommunication levels. Above, the bevelled shaft sections were interrupted at unequal heights, allowing extra service space for water tanks and mechanical equipment for the freight and public elevators. Culminating high above, the antenna was one third of the full 156-meter height of the tower (fig. 67).

Dimitri saw the tower in progress, but never became much involved in its design, the latter being carried out by Wigglesworth and Sung who produced presentation drawings and cardboard models in a three-week effort<sup>[173]</sup>. Soon after the announcement of the winning scheme, the Boumediene Tower project was abandoned by the Algerian Government, cancelling this memorial project to Houari Boumediene (1932-78), former President of the Republic<sup>[174]</sup>.

The La Laurentienne Building, Montreal, 1980-86, by Larose Laliberté Petrucci, Dimakopoulos & Associés, was another project commissioned by Bernard Lamarre, this time to accommodate the future Lavalin Headquarters. Managed by Marathon Realities and Lavalin, a first mandate was given to design a preliminary project which was subsequently interrupted for a year. By Spring 1982, the \$75 million project was reactivated and the final concept was developed<sup>[175]</sup>.

While the contemporary vogue for mirror glass curtain walls was the basis of the project, the owner required a prestigious building on a site adjacent to Dominion Square. This generated criteria for environmental integration and architectural quality<sup>[176]</sup>. A co-property of Marathon, Lavalin and the F.I.C. Fund, a branch of the La Laurentienne Group, the 27-storey office tower would include a total area of 75,000 square meters. It would be located on the former site of the Laurentian Hotel, at the corner of Dorches-

ter Boulevard and Peel Street<sup>[177]</sup>.

Assisted by Sung, Dimitri evolved the base building form consisting in a slab on an elongated hexagonal plan<sup>[178]</sup>. Four large, continuous and vertical bay-window strips protruding from the elongated front façade were covered by sloping roofs extending from the one-storey penthouse parapet. Facing the site of the CIBC Building, 1959-63, by Peter Dickinson (1925-61), which displayed a sculpture by Henry Moore (1898-1986) at street level, the building was respectfully set at 45-degree angle, creating a significant opening of the urban space at the entrance to Dominion Square (fig. 68)<sup>[179]</sup>.

The building envelope, inspired by the Bank of Canada Building, Ottawa, 1972-78, by Marani, Rounthwaite & Dick with Arthur Erickson, Associated Architects, was designed with receding angular corners<sup>[180]</sup>. Of similar concept, green mirror glass curtain-walls were selected to reflect the vegetation of the Dominion Square. Pre-oxydized copper for mullion caps and spandrels and a painted green metal fascia for the penthouse were also selected to match the copper roofs of the surrounding architectural landmarks<sup>[181]</sup>. The planning of the plaza with its planting, trees and waterfall also allowed a sensitive integration into the public square. The extensive use of granite slab pavement on the site matched the numerous stone buildings found in the neighbourhood<sup>[182]</sup>.

Reflecting the built environment, this Late-Modernist tower followed a tight contextualist approach, while the careful treatment of external surfaces gave a strong identity to the building within the Montreal skyline, similarly to its 45-degree setting<sup>[183]</sup>. Meticulous design, durable high quality materials, highly functional performance criteria and strong environmental integration concerns would allow the building to fit naturally into its histori-

cal neighbourhood context. By reactivating its prestige, it brought an important input to the future development of downtown Montreal<sup>[184]</sup>.

Continuity in the choice of materials was also found inside the building. The exterior granite slab pavement extended into the main entrance hall, visible through the clear glass hall partition<sup>[185]</sup>. This visual continuity was emphasized by the copper canopy structure extending inside the spacious glazed lobby. The lobby was also ornamented with a spatial sculpture, thus further integrating the design into the neighbourhood and the plaza<sup>[186]</sup>.

Designed by Dimitri in a sculptural fashion, the copper canopy featured a glazed and braced roof with sloped edge beams widening graciously at their two column connections, pursuing their course inside the lobby towards two other columns (fig. 69). Successful and significant, the marquee provided great spatial impact on the façade, indicating clearly the main entrance. Brass trim for revolving doors and similar entries provided an interesting contrast in the use of luxurious metallic materials<sup>[187]</sup>.

With retail stores at ground level, the 25 upper floors contained rentable office space. A mezzanine, accessible by elevator, also opened into the main hall space<sup>[188]</sup>. The vertical circulation was provided by 16 high speed elevators which had interiors ornamented with wall-to-wall murals by Jacques de Tonnancour (b.1917)<sup>[189]</sup>. The 4-storey basement included a 3-level underground parking garage for 329 cars. The mechanical and machine rooms were located in the penthouse at the top of the building.

While Dimitri Dimakopoulos & Partners were responsible for all the preliminary design and 50% of the working drawings, Larose Laliberté Petrucci, were also responsible for the administration, contract documentation and construction supervision<sup>[190]</sup>. After nearly two years of work, the

decision to build was taken in a marketing context where supply of space largely exceeded the demand.

The call for tenders was organized at the end of 1983 and Hervé Pomerleau Inc. became the general contractor with Marathon Realities acting as the Master of Works<sup>[191]</sup>. The construction was started in January 1984 and, on February 15, 1984, a ceremony marking its beginning took place at the nearby hotel Château Champlain, 1966, by Dastous & Pothier Architectes, where Mayor Jean Drapeau, Bernard Lamarre and other notables were present<sup>[192]</sup>. By April 1985, the building's reinforced concrete structure had reached its full height<sup>[193]</sup>.

The construction of this \$36.5 million building was completed by early 1986, allowing the Lavalin Headquarters to move in during the year, occupying 15 floors of the building on its fiftieth anniversary<sup>[194]</sup>. The La Laurentienne Group would occupy much of the remaining office space. Considered at the time the most prestigious office tower in town, it was the first building to be erected on this section of Dorchester Boulevard in nearly ten years (fig. 70)<sup>[195]</sup>.

Following the launching of a third architectural competition organized by the Provincial Government for the future Quebec Museum of Civilization in the Fall of 1980, Dimitri Dimakopoulos & Partners were not invited to participate<sup>[196]</sup>. Instead, Dimitri was nominated as a member of the jury including seven architects, three engineers and four public service representatives<sup>[197]</sup>. The competition between five consortia took place the next year and by October 1981, the results were published, announcing that the team of Moshe Safdie (b.1938) had won<sup>[198]</sup>.

Initiated in 1982, the Dawson College Atwater Campus, Montreal and

Westmount, 1982-97, by Dimitri Dimakopoulos & Partners and Jodoin Lamarre Pratte & Associés was a major retro-adaptation project in four phases extending over fifteen years and following a basically continuous process<sup>[199]</sup>. It started as a feasibility study for the conversion of the Mother-House of the Sisters of the Congregation Notre-Dame, 1903-06, by J. Omer Marchand (1872-1936) and Samuel Stevens Haskell (d.1913), into a new unified campus for Dawson College<sup>[200]</sup>. Designed in a French Beaux-Arts Neo-Renaissance/Byzantine style, the 37,160 square meter original complex extended into an elongated H-shape plan upon a vast landscaped site<sup>[201]</sup>. It featured the first reinforced concrete structure in Canada and the first Montreal religious building with yellow brick facing, a light material promoted by the Beaux-Arts School of Paris<sup>[202]</sup>.

Part of the same planning process, Phases I and II were construction phases for which execution was carried out between 1987 and 89 by V. K. Mason Construction<sup>[203]</sup>. This company dealt with the \$1.5 million demolition and \$29 million renovation works within the former Nunnery (fig. 71). The project started with an 18-month feasibility study consisting of a program to accommodate twelve of the thirteen existing Dawson campuses spread around town into the most important English CEGEP of the Province and the largest unified campus in downtown Montreal<sup>[204]</sup>. The purchase of the Nunnery was followed by an 18-month design process to accommodate the various academic groups within the existing facility<sup>[205]</sup>.

The project was carried out by Wigglesworth, while Dimitri and Sung were only involved on an occasional basis. Extending over the two city limits, the Nunnery included the Chapel, at 3040 Sherbrooke West, 1905-1908, by J. Omer Marchand and Samuel Stevens Haskell, designed in a

Romano-Byzantinesque Revival style and protected as an historical monument by the Quebec Ministry of Cultural Affairs<sup>[206]</sup>. Similarly, the Nunnery exterior façades in brick masonry, enhanced by granite elements, were protected as was the landscaped site itself.

Demolition, restoration and renovation plans were prepared together before the first contract was awarded. Practically all the interior spaces were gutted, most of them having to be demolished to allow major renovations<sup>[207]</sup>. While heritage elements were preserved wherever possible, the Chapel interior was completely restored (fig. 72)<sup>[208]</sup>. Renovated with minor changes, it was transformed into a main Reading Room for the Central Library (fig. 73)<sup>[209]</sup>. Similarly, the exterior bearing walls of the Nunnery which could not be altered were restored and received new windows<sup>[210]</sup>. Containing new classrooms, laboratories, offices, cafeteria and other services, the new functions generated a complete redesign<sup>[211]</sup>. This would involve a new atrium space replacing the former boiler room and connecting to a new main entrance and circulation space extending from de Maison-neuve Boulevard<sup>[212]</sup>. The Phase I and II project was ultimately completed for the September 1988 entry of 4000 students<sup>[213]</sup>.

On December 10, 1982, the Federal Government also asked Dimitri Dimakopoulos and Partners and Gordon Edwards Architects, as well as six other Canadian firms, to submit a concept for the future \$80 million National Museum of Man to be built in Parc Laurier, Hull, within the next five years<sup>[214]</sup>. The written proposal was to be prepared in a 8½" x 11" format, including sketches and plan illustrations. Featuring a basic architectural concept rather than a preliminary design, the study was concerned with urban context and institutional role, treated as an approach to an architectu-

ral solution including a major interior space<sup>[215]</sup>.

Very much involved, Dimitri participated in the design, heading a team of seven including Sung, Wigglesworth and Gordon Edwards (b.1930), acting as external Partner<sup>[216]</sup>. From December 13, 1982 until the January 17, 1983 deadline, the team worked very hard throughout the Christmas holidays. Its full time effort resulted ultimately in a night and day “charette”. When Dimitri had to go back to Greece for a week following his father’s death, the team was temporarily handicapped by his absence and was subsequently given a one week extension by the client<sup>[217]</sup>.

Dimitri’s project was conceived in a triple sequence of exhibits. At the main entrance facing Laurier Street, a major multi-disciplinary “Core Exhibit” provided a general introduction to the visitor, followed by a series of “Theme Exhibits” where the various topics were examined in greater depth. The “Study Exhibits” offered more specialized information to the serious visitors<sup>[218]</sup>.

Indicating a general direction, Dimitri’s final concept was selected out of four design options involving the construction of working models for which an evaluation was made from pre-set criteria and basic design concerns<sup>[219]</sup>. Offering greater potential, the selected option featured a building composed of a major articulated volume rising above Laurier Street and containing three floors of exhibition galleries, a main entrance space and an atrium. A secondary volume occurred under a “Place du Musée”, including offices and laboratories as well as a Library, Directorate and Cafeteria. The latter room opened two levels below street level in an open court convertible into a temporary exterior exhibition space (fig. 74)<sup>[220]</sup>.

Acting as a pavilion set in a park, the building offered optimized views



towards Parliament Hill, allowing other vistas from surrounding streets. Creating a sequence and variety of open spaces, the building featured a major east side circulation leading from a roof space urban square to the river edge park. Beyond the north-west reception, the three exhibition levels were apparent from the foyer and atrium where were found core exhibits, stores and public services.

Beyond the atrium were seen the thematic and study exhibits, the temporary exhibits being located one level above with an Imax Theatre. Visible from all storeys, the atrium would allow live performances, its open space developing into a transparent exhibition promenade offering a dynamic and exciting experience with spectacular views<sup>[221]</sup>.

This project, which Dimitri considered very important, never won the favour of the organizers in a contest managed in a rather unorthodox fashion. Sceptical from the beginning, Dimitri never appreciated the political flexibility appended to the selection rules and process<sup>[222]</sup>. Considering the design and technical capabilities of all participants, the Corporation reviewed the proposals, made its final recommendations to the Federal Cabinet and, on February 11, 1983, the Canadian Government appointed its architects<sup>[223]</sup>.

Formed after the competition, the two nominated consortia were Parkin/Safdie Architects Planners commissioned for the National Gallery with Moshe Safdie acting as Design Architect, and Douglas J. Cardinal + Tétrault Parent Languedoc & Associés commissioned for the National Museum of Man with Douglas J. Cardinal (b.1934) as Design Architect<sup>[224]</sup>. Renamed the Canadian Museum of Civilization, the Hull building was finally completed in 1989 at a cost exceeding \$182 million, while the National

Art Gallery was completed in 1988 at a cost of \$122 million<sup>[225]</sup>.

Between 1982 and 1986, Dimitri Dimakopoulos & Partners were commissioned to design five large residences for rich Saudi Arabian clients<sup>[226]</sup>. Dimitri spent a lot of time designing them according to Arabian formulas, following formalities in the inter-relation of rooms and producing a very specific kind of Modern Regionalist domestic architecture.

House #1, Riyadh, 1982-84, was commissioned by Doctor Algosabi, Minister of Health, in 1982. Dimitri designed a first project and went to Riyadh to present it. Built within two years, it was a relatively small, introverted urban house with typical high walls like most other houses in the Capital<sup>[227]</sup>. Including an interior court, it was much more formal and modest than the four others to come. Dimitri would inspect that house during and after construction.

The four other houses were to be located in Manama, Bahreïn, capital of an independent state of the Persian Gulf, an archipelago situated near the Saudi Arabian coast<sup>[228]</sup>. Facing the sea with nothing else around except sand and palm trees, these large country cottages included swimming pools, shaded terraces, arcades and screened windows allowing natural wind ventilation<sup>[229]</sup>. Much more extroverted than House #1, they included exterior recreational terraces relating to the sea. Very spread out, they were all finished in sand color painted stucco. Making use of local materials and technology such as reinforced concrete and concrete blocks, they were all of similar construction type. These houses, very indigenous in design and planning, followed the usual Arab formalities of living, with separate quarters for men and women. They were strictly planned in accordance with Muslim practice which pervaded the whole design<sup>[230]</sup>.

Very concerned with high-technology and electronics within the context of an extremely traditional life style and culture, these clients were all members of the Saudi Arabian Government. Their weekend holiday villas, with cloisters and arcades, were thoroughly vernacular, requiring a considerable amount of study by the architects during the design process<sup>[231]</sup>. For nearly five years, Dimitri went regularly to Bahreïn every six months for presentation, consultation and coordination, visiting most of the projects during construction. Design and contract drawings were produced by his office, while British local engineers were involved as consultants.

House #2, 1983-84, a very traditional structure, was built for His Excellency, Minister Y. Shirawi with a budget of \$1.5 million. House #3, 1983-4, was commissioned by His Excellency, Doctor Algosabi, with a budget of \$2 million, while House #4, 1984, was built for Sheik Zaki Yamani (fig. 75). Less traditional, this \$3 million villa, including an interior swimming pool pavilion, featured a higher level of modern technology and innovative design. Finally, House #5, 1986, was a later but smaller villa commissioned by Secretary Gaith<sup>[232]</sup>

In 1983, the consortium of Dimitri Dimakopoulos & Partners + Larose Laliberté Petrucci was commissioned to design the new No.2 Place Alexis Nihon office tower to be added to the existing multifunctional complex including a shopping mall infrastructure, an office and an apartment tower<sup>[233]</sup>. The new \$19 million 24-storey tower would extend 18 storeys above the existing podium roof and would contain more than 37,000 square meters<sup>[234]</sup>.

The designers had to take into account the existing infrastructure including foundations, columns, structure, mechanical systems and underground Métro station<sup>[235]</sup>. The lower storeys of the existing structure were

transformed into a public space at lobby level, including pools, fountains, escalator connection to street level and winter garden. Allowing direct access to the shopping center, the planning of the main lobby and atrium required partial demolition of the existing commercial plaza and underground parking<sup>[236]</sup>.

The constraint of the existing structure generated a heavy mass difficult to hide and the façades were articulated to compensate for the resulting bulky shape<sup>[237]</sup>. Hexagonal in plan and centrally located between the two original existing towers, the new building would feature a simple front elevation with a stretched out orthogonal grid on de Maisonneuve Boulevard. Matching the linear treatment of the apartment tower, a ladder effect created the illusion of height and narrowness. In the lower front elevation, two massive x-bracings set in the upper end compartments of a monumental six-square grid decorated the upper part of the podium façade. Featuring slim alternating set-backs, the bevelled façades were more articulated and a successful elegance could be achieved out of all the volumetric difficulties (fig. 76)<sup>[238]</sup>.

Dimitri was mainly assisted by Sung for the design, Wigglesworth acting as Project Architect, developing the contract documentation and supervising the construction<sup>[239]</sup>. The project was carried out at their office with some assistance from Gilles Larose's staff. Started in January 1985 by V. K. Mason Construction, the building was completed by Spring 1986<sup>[240]</sup>.

Following a major conflagration on October 26, 1986 in the No.1 Place Alexis Nihon office tower, a second commission was awarded to Dimitri Dimakopoulos & Partners and Larose Petrucci Martel<sup>[241]</sup>. This renovation project involved the total reconstruction of the tower, completely destroyed above the seventh floor and requiring the replacement of 50% of its original

steel structure. New elevators, service cores and stairs were introduced to bring the outdated tower up to the new building code standards. The \$19 million project was combined with a \$5 million renovation of the podium and its façades including a combined entrance lobby serving both office towers and allowing direct access to the shopping mall<sup>[242]</sup>.

For the purpose of visual integration, No.1. Place Alexis Nihon took some of the architectural vocabulary established in No.2 such as the metal cladding and detailing<sup>[243]</sup>. Supervised by Dimitri, the exterior wall design of No.1 was developed by Adriana Pancou<sup>[244]</sup>. It featured a collage of alternating vertical ladder sections set against a smooth continuous mirror glass curtain wall bevelled and cut out at the corners<sup>[245]</sup>. Tripartite in essence, the longitudinal office tower presented a strong base differentiated by large orthogonal members in its upper part. At the top, a discontinuous parapet featured Post-Modern arcuated fascias crowning large upper bay windows strongly delineated by framing members (fig. 77).

Transformed into a high-tech work of art, the new No.1 tower rose 16 storeys above street level<sup>[246]</sup>. Offering panoramic views, it featured ten floors of 2800 square meters each with a six-elevator lobby, three stair shafts, twelve corner offices on the two upper floors and three levels of underground parking for 1,100 cars.

Completed in April 1988 by Ain and Zakuta Construction, the Place Alexis Nihon renovation was a real architectural tour de force. Using Modern Functionalist, High-Tech and Post-Modern combined vocabularies to harmonize miscellaneous structures together, Dimitri achieved a successful contextual integration enhancing the architectural quality of a large complex located in an important urban area at the junction of Montreal and

Westmount.

During the early 1980's, Dimakopoulos & Partners were also involved in two consecutive projects for new bio-technological building facilities located in the Montreal area. Initiated first, the Biotechnical Research Institute for the CNRC, Montreal, 1983-87, by the architectural consortium David Boulva Cleve, Dimakopoulos & Partners and Gordon Edwards was soon followed by the Bio-Mega Laboratories, Laval, 1984-85, by Dimitri Dimakopoulos & Partners only<sup>[247]</sup>.

Managed by Public Works Canada for the Canadian National Research Council (CNRC), the first project was part of a special economical recovery project program launched by the Government of Pierre Elliott Trudeau (1919-2000) in Early 1983<sup>[248]</sup>. The first installation in a new scientific park for Montreal, it was a pilot project for a cooperative participation between the public and private sectors in biotechnical research. The consultant selection process followed standard procedures with submission proposals on limited invitations<sup>[249]</sup>. Since the future users remained undetermined, the very generalized program requested extreme flexibility for its 144-module laboratories devoid of any specific destination<sup>[250]</sup>.

Once commissioned, Dimitri and his team prepared in two weeks a preliminary concept proposal featuring site and functional relations analysis, design methodology and criteria studies, as well as one recommended option out of seven detailed alternatives<sup>[251]</sup>. Further developed, the final concept was presented to the client on October 3, 1983<sup>[252]</sup>. While Dimitri oversaw all conceptual work, Andrea Wolff pursued the design development and Wigglesworth acted as Project Architect<sup>[253]</sup>.

Located on Royalmount Avenue behind the Blue Bonnets Racetracks,

the 23-acre flat, windy and contaminated site was mostly devoid of interest apart from a distant view on the Mount-Royal<sup>[254]</sup>. A \$1 million landscaping project with planted trees areas of wind and snow protection was therefore developed, including a considerable amount of moulded land to create a pleasant environment complemented by a parking for 336 cars to the north-east<sup>[255]</sup>. The two-storey building was planned along a south-west oriented service spine with a front public entrance opening on the administration area which included a library and conference center.

Delineated by interior courts, two front wings of laboratories and offices were set diagonally, connected to the back longitudinal service spine including workshops, truck reception, an animal research facility and pilot research plant (fig. 78)<sup>[256]</sup>. Late-Modern in essence, the building presented an articulated plan with some angularity, flat metal siding with negative joints and modulated fenestration with tinted glass<sup>[257]</sup>. Animated by a distinctive semi-circular structure, the central cafeteria opened up into a protected interior court, constituting a pleasant central gathering place.

The circulation network was articulated from the entrance into the three wings, with two transversal passageways on three storeys crossing the interior courts and linking both laboratory wings. Allowing future expansion for all components, the building offered high-tech characteristics such as an ultra-performance thermally insulated envelope, sophisticated mechanical systems, precise confinement levels, flexibility and permeability for staff circulation<sup>[258]</sup>. With a color scheme of blue metal panels complemented by burgundy secondary elements, the front wing façades featured a rhythmic sequence of windows generating an animated pattern on the two upper levels while, at ground level, a continuous double strip of glazed partitions enclo-

sed by exterior columns allowed continuous views and natural lighting.

The construction, following a "Fast-Track" process, was initiated as early as October 1983 with a first contract for the site preparation<sup>[259]</sup>. It was followed by another \$3.3 million contract for the concrete foundation and steel superstructure. Initiated on April 4, 1984, these works lasted only 19 weeks. Starting on July 23, 1984, the third and last construction phase involved a \$20.6 million general contract including the base building and landscaping, awarded to Construction Château Saint-Marc<sup>[260]</sup>. Late design changes took place, and the \$29 million project was only completed in early 1987, due in large part to a poor performance by the contractor (fig. 79)<sup>[261]</sup>.

Overlapping in time, the Bio-Mega Laboratories was a "Fast-Track" custom-made project answering the specific needs of a company created in 1983 and owned by the Société Générale de Développement du Québec<sup>[262]</sup>. This biotechnology firm, specializing in pharmacology and diagnostics research, also required a production plant<sup>[263]</sup>. Housing an animal research facility, the new complex would include laboratories for medicinal chemistry, bio-chemistry, pharmacology and micro-biology<sup>[264]</sup>.

Under the management of Prodevco-Lavalin acting as Master of Works, the \$11 million project was quickly conceived from mid-1984 onwards to be built within a year<sup>[265]</sup>. Much more involved in the design than for the CNRC project, Dimitri developed the program and site analysis into its final concept, defining the basic form of the building. The design development was carried out by Andrea Wolff while Wigglesworth acted as Project Architect<sup>[266]</sup>.

Conceived for a wind swept and hostile environment at the junction of



the Laurentian and Laval Highways, the dynamic design for this building was conceived with dramatic variations in its volumetry<sup>[267]</sup>. The structure highly visible from cars moving above and below at a distance of a few hundred feet, was introverted and auto-sufficient, opening inwards on a centrally located internal atrium<sup>[268]</sup>. Displaying some forms dictated by function, the concrete infrastructure complex with steel framed super-structures also presented sophisticated mechanical ventilation and air filtration systems<sup>[269]</sup>.

Sculpturesque in essence, the building offered multiple changes in perception from multiple view points. A green, cream and red colour scheme expressive of its ecological, biological and organic orientations was chosen, the client desiring a strong architectural statement for a memorable building<sup>[270]</sup>. The building, easily identifiable on a strip of banality strewn with ordinary commercial structures, would demarcate itself from the others by its highly original architectonic and colorful vocabulary. It was laid out on a quasi-symmetrical plan with the entrance and administration at the front, two lateral wings of laboratories crowned by mechanical vaults on each side and a production plant at the back (fig. 80)<sup>[271]</sup>. The whole complex focused on a landscaped sky-lighted atrium of 100' x 60' served by an adjacent cafeteria and acting as an informal meeting place for the staff (fig. 81)<sup>[272]</sup>. The plant also included researchers' offices, library, pilot plant, animal research facility, etc<sup>[273]</sup>.

Winner of the Award of Excellence of the Association de Maçonnerie du Québec in 1986, the building presented a sophisticated envelope with varying colors, textures and materials<sup>[274]</sup>. It included an innovative cream coloured ceramic veneer on a full-size square tiling pattern coating on

concrete blocks of regular size<sup>[275]</sup>. This unusual veneer treatment covered the orthogonal projecting volumes of the three main façades perforated with series of windows of various sizes and rhythms. It was complemented by ribbed or flat aluminum siding mainly used at roof level and on the full-height recessed corner volumes where quadrant barrel domes were used to achieve roof connections. While red cylindrical columns recessed in glazed niches ornamented the building corners, a full arch barrel dome on axis covered the entrance area.

This highly successful building was the first attempt by Dimakopoulos & Partners to work in the Post-Modern idiom<sup>[276]</sup>. Displaying dynamic contextualism and organic symbolism, dualism and multivalence in its architectonic treatment, this strange quasi-symmetrical structure presented a toy-like tactile volumetry, unveiling an hybrid nature in its harmonious, geometrical and organic shapes and colors<sup>[277]</sup>. Clearly identifiable by its "speaking architecture", it offered an eloquent architectural statement for an avant-garde scientific biotechnical laboratory.

The general contract was awarded to Hervé Pomerleau Inc. and the first sod was turned on November 12, 1984<sup>[278]</sup>. Scheduled to open in July 1985, the building was finally occupied in September 1985<sup>[279]</sup>. The center offered at that time 5600 square meters for more than 90 researchers<sup>[280]</sup>.

As early as November 1983, an open architectural competition for a new \$15 million Musée d'Art Contemporain de Montréal was launched by the Provincial Government, allowing the participation of all Quebec Registered Architects<sup>[281]</sup>. A total of 111 participants submitted their proposals to a jury of seven members before the April 16, 1984 deadline, including the consortium of David Boulva Cleve and Dimakopoulos & Associés<sup>[282]</sup>.

The project was carried out by a team of 5 people including Dimitri, Jacques L. David, Magda Kuskowski, Angelo Manzo and Willy Sung<sup>[283]</sup>. A separate project office located on the 8th floor of the 1253 McGill College Building was used for the competition<sup>[284]</sup>. From the beginning, Dimitri's contribution was maximal and the project ended up in a "charette" lasting more than two weeks, including sessions that ran into the night.

Dimakopoulos soon discovered that the program requested a building site envelope disrespectful of the urban design parameters originally conceived for the Place des Arts Masterplan<sup>[285]</sup>. Questioning the program, the team found out that it was fundamentally inappropriate for such a major institution, and the team had to force the gallery spaces and volumes into a very tight and narrow site along Jeanne-Mance Street. Selected from a few conceptual options, their resulting project was not as exciting as originally anticipated because of these major constraints<sup>[286]</sup>.

Displaying a similar architectonic language to that of the Palais de Justice de Québec and the Frieman Mall, the architectural scheme was characteristic of Dimitri's bold and sculptural Late-Modernist treatment for large exterior volumes articulated by the interplay of masses and voids, chiaroscuro effects, contrasting materials, textures and colors.

Presenting a long broken west three-storey elevation on Jeanne Mance Street, the building was basically planned as a parallelepiped narrowing toward the south. A monumental south façade, set diagonally on the southwest corner of the plaza, opened broadly on Jeanne Mance Street, framed by two large recessing side piers connected by an elongated upper front span<sup>[287]</sup>.

Displaying recessed accordeon-like curtain walled volumes rising above

the roof parapet, the building was further articulated by a linear multi-storey glazed arcade culminating above the east façade and opening on the exhibition galleries. The interior spaces, designed by Sung, offered some of his personal characteristic details such as flying beams with cylindrical knuckle articulated connections (fig. 82)<sup>[288]</sup>.

Following the deliberations of a jury headed by Ray Affleck, eight winning projects were unveiled to the public on June 19, 1984<sup>[289]</sup>. While three main prizes were awarded to other local firms, Dimitri's consortium won an honourable mention with four other participants<sup>[290]</sup>. From July 1st to September 16, 1984, an exhibition intitled "Architectures du Musée" was held at the Musée d'Art Contemporain de Montréal, located then at the Cité du Havre, where Dimitri's project could be seen with the seven other winning schemes<sup>[291]</sup>.

By mid-1984, Dimitri Dimakopoulos & Partners were also hired as Consulting Architects by the Architects Partnership of Hong Kong to design an \$80 million Hilton International Hotel for Shanghai, the first to get built in the Republic of China<sup>[292]</sup>. The developer of the Jing An Hilton Hotel, Shanghai, 1984-87, was Cindic Hotel Investments Co. Ltd, headed by Alex Chu, formerly employed by Dimitri, who also acted as Project Manager<sup>[293]</sup>.

From the start, Dimitri was quite involved in this project, using his standard design procedures to develop the concept. The preliminary design was carried out by Sung, ultimately assisted by a drafting team to produce the final colored presentation drawings<sup>[294]</sup>. Following a fast design process from July to October 1984, the building was scheduled for completion by May 1987<sup>[295]</sup>.

The hotel, located in the center of a large city block adjacent to Huashan

Road, a main artery connecting Downtown Shanghai to its airport, featured a vast 4-storey quasi-rectangular podium on top of which a triangular tower would rise 37 floors. Facing a large open green space to the south and the International Club recreational facilities to the north, the complex was accessible from the east via Huashan Road. Sharing its site with the 11-storey existing structure of the refurbished Jing An Guesthouse to the south-west, the complex was defined by four tree lined alleys allowing efficient vehicular circulation (fig. 83)<sup>[296]</sup>.

The hotel was designed as a unique Late-Modernist landmark, offering the highest standards of quality and the latest technology, and well integrated into its Chinese context. With appropriate vehicular circulation patterns created for cars, buses and trucks, the impact of the 4-storey podium height was minimized, optimizing at the same time the exposure and interface of its public facilities with the immediate surroundings<sup>[297]</sup>.

Regrouping its service activities at the back, the podium featured at its front arrival point a main entrance lobby and spacious hall with reception counter and elevator core to the north. Topped by a partially glazed interior swimming pool on the roof, a front square pavilion with bar-lounge at ground level protruded dramatically from the south-east corner<sup>[298]</sup>.

The spacious hall opened towards the back on a vast, vertical and longitudinal planted atrium with a coffee shop and boutiques. One could easily find in the basement a Chinese restaurant and discotheque, a 78-car parking garage and complementary service spaces. The second level, accessible through a grand staircase or by elevator, contained functional activities such as a ballroom, meeting rooms and the main restaurant, offering impressive views towards the exterior gardens<sup>[299]</sup>.

The third level, reachable by stair and elevator, contained smaller meeting rooms, business and computer centres, administration and services. On the roof of the podium, at the fourth level, was found an exquisite landscaped exterior terrace with bar and lounge, enclosed swimming pool and health club at the front, while service spaces at the back were topped by an exterior tennis court<sup>[300]</sup>.

The triangular tower included a lower mechanical floor, sixteen lower guestroom floors, an intermediate refuge/mechanical floor, sixteen upper guestroom floors, a restaurant/entertainment lounge floor, an upper mechanical floor and a roof helicopter pad culminating at 139 meters. The tower was located in the north-east corner of the podium, minimizing visual obstruction and shadow effects while optimizing the panoramic views and privacy of the 771 guest-rooms<sup>[301]</sup>.

Presenting two northern Z-shaped cut out corners, the tower displayed on its southern face, two exterior semi-circular panoramic elevators facing the podium roof terrace below and running in a protruding rectangular vertical shaft. Two glazed vertical strips curved on quadrants provided an elegant transition towards flat recessing blank wall strips on each side, generating a dramatic profile for the main corner of the tower visible from Huashan Road (fig. 84).

The tower, served internally by six passenger and four service elevators contained 25 spacious guestrooms per floor. Except for the two front rooms beside the panoramic elevators presenting a fully glazed wall on quadrant, the 23 remaining rooms featured wall-to-wall panoramic bay-windows.<sup>[302]</sup> They generated animated elevations with elegantly embossed vertical window strips interrupted at the bottom, middle and top levels by blind horizon-

tal strips of recessed mechanical louvres<sup>[303]</sup>.

Presenting Late-Modern zigzaging angularities and high-tech characteristics, the hotel design also displayed some Regionalist vernacular concerns, recommending the selection of high quality local materials, as well as Chinese artifacts and ornamentation<sup>[304]</sup>.

By mid-1985, the consortium of Jodoin Lamarre Pratte & Associés and Dimitri Dimakopoulos & Associés was commissioned by the Government of Quebec for the second phase of the UQAM Downtown Campus. This \$51 million project included a new complex for the Athanase David Site (Block B) facing Pavillon Judith Jasmin (Block A) on Saint-Denis Street and a new pavilion for the Dorchester Site (Block C) located at the corner of Berri Street and extending from Pavillon Hubert Aquin<sup>[305]</sup>.

For both buildings, the architectural design criteria demanded masses of varying volumetry conceived in harmony with the surrounding urban and pedestrian scales. Matching the nearby building materials and offering a fenestration allowing for maximal natural lighting, both structures would be inter-connected to the Berri-UQAM Métro underground pedestrian network<sup>[306]</sup>.

On the Athanase David Site was found Place Pasteur, a small historical urban square facing the Saint-Jacques Church tower and spire, as well as the former Université de Montréal main pavilion, 1901-02, by Joseph-Emile Vanier (1858-1934), transformed into the Ecole Polytechnique de Montréal from 1905 to 1958<sup>[307]</sup>. Expanded to the north and renovated by Ludger Venne (1891-1973) in 1939, the building also featured an adjacent Art Déco façade deserving preservation and restoration<sup>[308]</sup>.

The general planning of the quadrilateral, featuring an H-shaped build-

ding of 18,000-square meter floor space, defined Place Pasteur as the focal point of the complex, to be transformed from a parking lot into a green space and pedestrian area (fig. 85)<sup>309</sup>. Similarly, the Classical Revival façade of the former Ecole Polytechnique deserved restoration while the rest of the building allowed some interior renovation.

Very much involved in the conceptual stage, Dimitri was assisted by Sung in the design development of a project including a six-storey and 11,378-square meter South Wing on Sainte-Catherine Street called Pavillon des Sciences de la Gestion, a 4,122-square meter renovated central East Wing housing the rectorate, vice-rectorate and administration called Pavillon Athanase David and a shorter North Wing on de Maisonneuve Boulevard housing a 4-storey and 2,500-square meter Pavillon de Musique with high-tech facilities including a specialized library and small concert hall<sup>310</sup>.

Echoing the Neo-Classical and Art-Déco elements of the existing façades, the contextualist treatment of these new wings made use of a Post-Modern Classical “free-style” and contemporary architectonic vocabulary<sup>311</sup>. The complex, covered with light brown ochre brick, would present stone-like precast concrete elements mimicking the existing pilasters, fascias and parapets. Copper roof siding for mechanical penthouses would also reinforce the necessary urban design connection between Phases I and II.

Because of its elongated mass, the South Wing displayed a façade broken in three identical parts by two recessed intermediate sections. Demarcating the main entrance with an arched Palladian motif, the southern section was much wider, featuring a quasi-integrated brick campanile with



gabled roof sided by two curtain-walled vertical boxes projecting on each side<sup>[312]</sup>. Featuring three groups of triple glazed store-fronts set between heavy pilasters at street level, a continuity of stores bordering Sainte-Catherine Street maintained its commercial vocation (fig. 86). Reinterpreting the traditionalist Neo-Classical vocabulary of the Ecole Polytechnique façade with Post-Modern Classical “free-style” motifs, the new wing echoed its pediments, cornice, pilasters and large Roman windows as well as its own upper storey expansion<sup>[313]</sup>.

In a similar fashion, the North Wing echoed the Art Déco motifs of the surviving façade addition, characterized by high and narrow double-storey windows and smaller rectangular openings and motifs. Accommodating a Métro entrance on Saint-Denis Street, it allowed future expansion for an 800-seat Concert Hall Pavilion at the corner of Sanguinet Street<sup>[314]</sup>. Similarly, a planted green space allowed future expansion and access for a 180-car underground parking garage at the back of the Central Wing<sup>[315]</sup>.

On the Dorchester Site, the 8,000-square meter Pavillon Thérèse Casgrain accommodating the Human Sciences departments was designed with an adjacent temporary park and playground to the west allowing for future expansion<sup>[316]</sup>. Reinterpreting a similar architectonic vocabulary, the building featured stepped back roof terraces culminating on Dorchester Boulevard and extending from the Pavillon Hubert Aquin. The pavilion, displaying a distinct personality, used a different rhythm, scale and fenestration interplay. On Dorchester Boulevard, a Post-Modern campanile, echoing the Saint-Jacques Church spire, signaled a main entrance protected by a glazed gabled roof (fig. 87)<sup>[317]</sup>.

At street level, a crescendo of multi-storey recessed curtain-walled bays

set between brick pilasters culminated with a pedimented roof fascia bay on each elevation. At the street corner was found a free-standing pier defining an open space allowing shelter for pedestrians.

The Pavillon Thérèse Casgrain, located at 455 René Lévesque Boulevard, was first inaugurated on the 5th of October 1989, eleven months after the original construction completion time schedule<sup>[318]</sup>. For the occasion, representatives of the UQAM administration and consulting firms were present. Then, on June 5, 1992, the \$63 million three-winged Athanase David Complex was inaugurated by new Montreal Mayor Jean Doré (b.1944) and UQAM representatives two years after the original construction completion time schedule<sup>[319]</sup>. On October 13, 1993, there was finally held a third inauguration for the \$20 million Pavillon de l'Éducation, 1989-93, also designed by the same architects<sup>[320]</sup>.

Completing Block C, this building offering a 16,353-square meter floor area included a large specialized library for the department of kinanthropology, a cafeteria and gymnasium as well as 293 offices, 18 secretariates, 71 laboratories, 20 classrooms, 3 amphitheatres, 7 meeting rooms and other facilities<sup>[321]</sup>. The new pavilion, comprising 9 storeys and 3 underground levels, was linked to both existing adjacent pavilions on the three lower storeys.

Evolving from a stepped back volume on Saint-Denis Street towards a straight parallelepiped with bevelled corners, the final building design featured glass and metal curtain walls with horizontal strips of windows complemented by central masonry bays protruding from the main elevations<sup>[322]</sup>. These irregular masonry bays, rising straight beyond the bevelled mansard roof parapet, presented a contrasting treatment of frame

horizontal window openings. Providing interiors with wide fenestration and circulation areas, the new pavilion was pleasant, functional and well integrated to the rest of the campus<sup>[323]</sup>.

The ultimate Phase II addition was the \$9 million Centre Pierre Péladeau, 1991-92, by the same architectural consortium, located at the corner of de Maisonneuve Boulevard and Sanguinet Street<sup>[324]</sup>. Housing an 800-seat Concert Hall with orchestra pit named the Salle Pierre Mercure, the building was dedicated to music and dance representations<sup>[325]</sup>. While the base building was originally conceived by Dimitri and Willy Sung, the building enclosure and concert hall were ultimately redesigned to conform to budgetary cut-backs defined by Scéno-Plus, a Montreal firm specializing in scenography which acted as Project Manager<sup>[326]</sup>. Well integrated to the adjacent Pavillon de Musique, the building would feature a very sober parallelepiped brick volume of similar height with vertical window openings on the front entrance and interior court façades.

Including a small administrative area at the entrance, the building was equipped with service rooms in the basement. Presenting a mezzanine, the Salle Pierre Mercure was accessible at three levels from a narrow foyer. The Centre Pierre Péladeau was put into operation on October 22, 1992.

In mid-1987, the consortium of Dimitri Dimakopoulos & Associés and David Boulva Cleve was also engaged by the Société de la Place des Arts de Montréal to undertake a study for the upgrading of the Salle Wilfrid Pelletier which had housed continuous performance for 24 years<sup>[327]</sup>. The objectives of the client were to make it more adaptable to a variety of shows, including Broadway Musicals. They also intended to facilitate quicker turn-over between productions, improve the general acoustics, modernize

and upgrade the stage equipment and enlarge the orchestra pit<sup>[328]</sup>. Among others, the Orchestre Symphonique de Montréal, the Opéra de Montréal and the Grands Ballets Canadiens were the major users to be considered<sup>[329]</sup>. During the following months, a preliminary technical report was prepared by the architectural and engineering consultants.

One year later, the architects were re-engaged to implement the project. While Dimitri himself had little to do with the project, David Wigglesworth acted as Project Architect<sup>[330]</sup>. The \$11.4 million project involved the expansion and renovation of the stage and back-stage areas of the 2900-seat hall, generating a much larger reconstruction of the original building backstage volume<sup>[331]</sup>. Involving the doubling of the stage area and wings, a new backstage rehearsal hall, new dressing rooms, new offices for the various users, reconfiguration of the orchestra shell and pit, improvement of the concert hall acoustics, complete renovation of the stage-house equipment and rigging, new elevators and an enclosed double truck dock, the construction works were achieved without interrupting the ten month regular performance schedules (fig. 88)<sup>[332]</sup>.

The new external envelope of the building expansion, designed by Hamira Khouri, a young Iranian architect, improved dramatically the appearance of the back elevation originally conceived solely for truck service access<sup>[333]</sup>. Following a similar configuration to that of the original scheme, the three-storey expanded volume was doubled in surface, with an overall height slightly increased<sup>[334]</sup>. Kept similar, the exterior wall treatment featured vertically ribbed precast concrete panels with four rather than two intermediate horizontal joints.

Displaying on its sides a piano-like motif, the building shell presented

two continuous bands of vertical windows turning the rounded corners and extending beyond towards the main central axis. The upper was interrupted by an horizontal glazed window-wall centered on axis. Much shorter in height, the lower band continued its course around the perimeter. At street level, the middle elevation presented two longitudinal opened bays on axis complemented by two shorter ones opening on the corners (fig. 89).

Wigglesworth, continuing with the interior modifications, managed the design, technique and administrative aspects of the project, preparing multiple presentations for the various participants, including the Ministère de la Culture, the Société de la Place des Arts, the Orchestre Symphonique de Montréal, etc.<sup>[335]</sup>. The construction works, started in 1988, were executed in multiple phases and completed in 1992 at a cost of \$18 million<sup>[336]</sup>.

By mid-1988, the consortium of Dimitri Dimakopoulos & Associés and Jodoin Lamarre Pratte & Associés was recommissioned for the third phase of the new Dawson College Atwater Campus. The program of this expansion featured the construction of the central and south-east pavilions of the new de Maisonneuve wing, excluding the future \$18 million south-west pavilion of the 1994-97 fourth and final phase<sup>[337]</sup>.

Incorporating a direct underground connection to the Atwater Métro Station and a new main entrance and atrium centrally located on de Maisonneuve Boulevard, the new south-east pavilion rose three storeys above ground, complemented by two mixed-use underground levels<sup>[338]</sup>. It accommodated the Dawson Institute of Photography as well as the Visual Arts Department and included mainly classrooms, offices, studios and laboratories<sup>[339]</sup>.

While Wigglesworth acted as Project Architect, Sung contributed from

time to time to the design, developing concepts and drawing perspectives (fig. 90). Dimitri himself was also involved in the site and program analysis, conceptual studies, design reviews as well as the 1% art integration program<sup>[340]</sup>.

A Post-Modern contextualist approach was used for the design of the new \$10 million structure in order to harmonize with the historical building<sup>[341]</sup>. Materials included a beige brick similar to that of the original Motherhouse, precast artificial stone, copper roofs and tinted bronze glass fixed windows (fig. 91). The definitive form and exact location of the pavilions were negotiated with the cities of Westmount and Montreal, generating amendments to existing by-laws<sup>[342]</sup>.

Following the mid-1988 commission, a 6-month period was spent for conceptual studies before the early-1989 final preliminary design presentation. Without delay, the project evolved immediately into the contract documentation stage after eleven months of preliminaries<sup>[343]</sup>. The call for tenders took place in September 1989 and the excavation was started later in the Fall. By late-1990, the construction of Phase III was completed, allowing the south-east pavilion to open for the January 1991 session<sup>[344]</sup>.

In February 1988, the consortium of Dimitri Dimakopoulos & Associés and Lemay Associés had also been awarded the commission for Le 1000 de La Gauchetière, a new major office tower for Montreal originally budgeted at \$125 million<sup>[345]</sup>. The largest commission in Dimitri's career, this building of 45 storeys, including 92,900 square meters, would be the tallest and most luxurious office building in Montreal, located on a quadrilateral defined by de la Cathédrale, de La Gauchetière, Mansfield and Saint-Antoine Streets<sup>[346]</sup>. The site was located at the southern end of Dorchester Square, allowing

for spectacular perspectives and offering appropriate breathing space for a high-rise structure<sup>[347]</sup>.

Integrating below ground the STRSM South Shore Bus Terminal, the complex would also be connected to the Montreal weather-protected pedestrian network with direct links to the major railways and Métro stations. The complex, scheduled to open in Spring 1991, included, in addition to office and commercial space, a 25-meter high atrium with winter garden, a four-seasons glazed interior skating rink surrounded by café-terrasses and a large underground parking garage<sup>[348]</sup>.

Initiated by Bernard Lamarre, President of Société Prodevco-Lavalin, the project was owned and developed by a tripartite equal joint venture acting as the Master of Works. It included the Groupe BCE, a Groupe Lavalin Ltée subsidiary, and Teleglobe Canada Inc., the latter two being future tenants and leasing 55% of all space<sup>[349]</sup>.

Elaborated at Dimitri's office in the summer of 1988, the Post-Modern tripartite architectural composition was derived from its urban context, recognizing to the proximity and relationship of the Neo-Renaissance Marie-Reine-du-Monde Cathedral, 1870-94, by Victor Bourgeau and Père Michaud, a prestigious local historical landmark standing nearby and flanking Dorchester Square<sup>[350]</sup>. Dimitri's intention was "to express the soul of Montreal" rather than to implant a foreign structure<sup>[351]</sup>.

By means of formal and material architectonic associations, the tower would take on the role of an Italian campanile, complementing the Cathedral and symbolizing the French Canadian Catholic faith<sup>[352]</sup>. Taken as design parameters, the dome, height and general characteristics of the nearby landmark were reflected in the design<sup>[353]</sup>. Such early concepts generated

the four podium corner rotundas topped by copper domes, and the tapered copper/tinted glass roof crowning the built structure and recalling the joined hands gesture for prayer<sup>[354]</sup>. On the same premises was introduced a steeply pitched glazed roof front entrance on de La Gauchetière complemented by a classicizing colonnade on both sides.

Leading the design, giving directives and taking major decisions, Dimitri, assisted by Sung, proceeded to the site and program analysis, animating brain storming sessions and defining the design criteria and concepts. Close to 50 schemes were evolved on sketches, while the general massing was studied with numerous 18" cardboard models<sup>[355]</sup>.

Christopher Erickson, working at Dimitri's office, developed the design of the exterior envelope, studying seven or eight alternatives until the final concept gradually evolved<sup>[356]</sup>. By January 1989, a preliminary design front elevation was published in a local newspaper<sup>[357]</sup>. Stepping back laterally on three levels above the podium, the rest of the tower shaft rose straight towards the crown.

The designers broke down the sheer mass of the building and reduced its scale by means of secondary and tertiary elements, developing its forms, textures and colours to contribute to a perfect and timeless urban integration<sup>[358]</sup>. Four recessed and profiled tinted glass corners would accentuate the visual effect of verticality and ascension<sup>[359]</sup>.

Below the crown was found a sequence of four decorative rectangular hollow frames stepping down towards a large arcuated tinted glass bay-window. The latter was originally conceived for an internal high open space accomodating a conference center (fig. 92) <sup>[360]</sup>.

All subsequent preliminary design drawings were evolved at Dimitri's



office on drafting tables, with no computer assistance. Based on contextual concerns, a grey colored granite suggested by Bernard Lamarre was adopted by Dimitri, who then, selected a natural copper finish for the spectacular tinted glass peaked roof echoing the four lower copper domes. The curtain-wall ultimately featured a sophisticated relief grid of protruding angular beige/pink granite vertical members superimposed on recessed clear glass window strips and grey granite spandrels<sup>[361]</sup>.

Presenting an inventive underground connection between the bus terminal, Métro and parking garage, the podium was carefully designed by Dimitri himself who developed the interior skating rink and winter garden concepts. Topped by a spectacular conical glazed roof, the four seasons skating rink gave a typically Québécois flavour to the project (fig. 93)<sup>[362]</sup>. Illuminated by two skylights, the winter garden included a waterfall, two monumental stairs and two escalators leading to the mezzanine<sup>[363]</sup>.

Before the end of the preliminary design, computerized working drawings were initiated by Lemay & Associés. In early 1989, a general multi-phase construction contract was awarded to the Groupe Pomerleau Inc. with an overall budget of \$250 million including fees, site and construction. By March 1989, the site was quickly excavated, remaining unactive for the rest of the summer. During the preliminary design, Dimitri and Wigglesworth were also involved in complementary building science studies dealing with sunlight, shadow, wind and snow effects<sup>[364]</sup>.

However, the construction work did not progress as quickly as expected. Due to unexpected financial losses and a sustained economic recession, Lavalin was forced by September 1990 to reduce its participation and budget from \$190 to \$150 million<sup>[365]</sup>. This generated a major redesign for

the architectural consortium which lasted more than 6 months. Many delicate and expensive details were modified, especially at the podium levels, resulting in a cheaper general appearance<sup>[366]</sup>.

By early 1991, Brookfield Development Corporation was brought into the project to replace BCE Development Corporation. Acting as co-owner, marketing promoter and development manager, the Quebec branch of this multinational American firm based in Toronto completed the \$160 million tower which was partly occupied in Early 1992 and inaugurated on September 17, 1992<sup>[367]</sup>.

For the occasion, Dimitri was present with his partners at a joyful ceremony featuring speeches by ten guests of honour, including Montreal Mayor Jean Doré and other Governmental and corporate representatives. It was followed by a world-class skaters gala event intitled “1000 Emotions”, which took place in the Bell Amphitheater. Supported by an infrastructure base of eight storeys including four underground levels, the 51-storey tower rose 205 meters above the ground culminating proudly in the Montreal skyline (fig. 94) <sup>[368]</sup>.

One of the few exemplary buildings in Montreal designed by a local architect, Le 1000 de La Gauchetière added a strong visual asset to the downtown core. Proud of his achievement, Dimitri considered the building as a world-class architectural landmark (fig. 95). Reinforcing the personality of Dorchester Square by means of careful and meticulous detailing, it was considered by then as one of the three most spectacular buildings erected in the city during the past 30 years. Very popular, its silhouette soon became adopted as an icon for the Montreal urban silhouette<sup>[369]</sup>.

In late-1988, an urban design competition on limited invitation was

organized by the Société Place des Arts with the objective of optimizing the Place des Arts urban site as a new cultural focus in the heart of Montreal.<sup>[370]</sup> While the original concepts of the ADDLMS Masterplan had never been implemented, the moratorium on the construction of the Musée d'Art Contemporain still allowed major design interface adjustments.

The main objectives of the program were to reconcile the differences between the building volumes, to improve the configuration of the exterior spaces, to harmonize the buildings and open spaces together, to soften certain aspects of the site including the impact of the MAC interface and to allow a full-year use for the plaza<sup>[371]</sup>.

The program requested an articulation of vast areas into a series of spaces of various scales, allowing for a unified synthesis through proper architectural and landscape vocabulary treatment. A progressive arrangement of spaces varying from active to intimate was suggested while integrated artworks would encourage pedestrian discovery<sup>[372]</sup>. The theme focused on the integration of components and maximizing the visual and circulation links between the buildings as well as the underground and exterior levels of the plaza.

Dimitri Dimakopoulos & Partners were invited to participate with a few other firms and proceeded quickly with the project. Working day and night for a period of two weeks, Dimitri, Sung and Wigglesworth carried out the site and program analysis, evolving conceptual options and selecting a final design solution. At the last minute, four coloured presentation panels were delivered to the organizers of the competition and within a week, Dimitri and his partners knew they had won the first prize and the commission.<sup>[373]</sup>

Displaying Neo-Modern Classical restraint, Dimitri's project offered

great visual and functional qualities, integrating the whole complex into a world-class unified urban plaza open to all Montrealers<sup>[374]</sup>. Transforming Place des Arts into a major civic centre and open air oasis, its exterior spaces would include inviting terraces and promenades, fountains, pools and waterfalls, integrating buildings, terraces and landscaping altogether (fig. 96)<sup>[375]</sup>. Improving perceptibly the aesthetics of the site as well as its access, Dimitri's project also generated a positive impact on the surrounding urban context.

Meeting immediately after the results with his client, Dimitri was soon involved in the intensive development of the preliminary design which lasted more than six months<sup>[376]</sup>. This was followed by a half-year interruption during which the program would be consolidated and detailed. By late 1989, the project was reactivated and, for a period of 16 months, Alina Morek finalized the design development while Wigglesworth acted as Project Architect in charge of coordination and contract documentation<sup>[377]</sup>.

Strategically located between the Museum and the Plaza entrances, an inviting monumental stair planned on quadrant with spacious landings pursued its course along the Museum towards the Main Concert Hall<sup>[378]</sup>. It greatly enhanced the spatial flow between the two main levels and offered multiple viewpoints (fig. 97). It offered a large urban space for pedestrian circulation and rest, but could easily be transformed into an open air amphitheatre for artistic performances<sup>[379]</sup>.

Facing the concert hall on axis and overlooking Sainte Catherine Street, a rectangular basin with water jets, convertible into a skating rink in winter, offered animation and relaxation to the passers-by<sup>[380]</sup>. An elongated curvilinear cascading water basin, skirting the east façade of the Museum, offered

the pedestrian a refreshing sound and atmosphere which encouraged further exploration<sup>[381]</sup>. Bordering the sides of the Concert Hall, two large lawned areas with curving footpaths linked the central monumental stair to planted corner areas along de Maisonneuve Boulevard.

In addition, the replanned central foyer of Salle Wilfrid Pelletier was made directly accessible from Sainte-Catherine Street<sup>[382]</sup>. Allowing more natural lighting at the lower level, the enlarged interior pedestrian passageway facing Place Desjardins was laid out with a large central circulation hall allowing direct access to the theatre and museum on each side<sup>[383]</sup>.

Below the south-west monumental stair was found information counters and stores for the Place des Arts and Museum. At the back, a semi-circular open atrium would provide natural lighting to the central circulation hall, offering a transitional promenade toward the Museum facilities<sup>[384]</sup>.

Under the management of the Société Place des Arts acting as the Master of Works, the \$10 million construction project was started in the summer of 1991, pursuing intensively its course until its official inauguration on May 28, 1993<sup>[385]</sup>. For the occasion, Mayor Jean Doré, Roger D. Landry, Chairman of the Board of Directors of the Société Place des Arts, and Liza Frulla-Hébert, Quebec Minister of Culture, spoke of the completion of a great square acting as an important cultural symbol and witnessing an important progress in the quality of life of citizens (fig. 98)<sup>[386]</sup>. Offered by the various Place des Arts tenants, a great open air show followed, attended by hundreds of Montrealers<sup>[387]</sup>.

During the course of the 1980's, Dimitri's firm was also involved in a series of secondary commissions, including the \$3 million renovation and expansion of the Nihon Residence, Westmount, 1987-89, and that of \$2.5

million for the Apache Residence, Dorval, 1989-93<sup>[388]</sup>. In both cases, the original mansions were expanded to accommodate larger living rooms, family rooms and bedrooms<sup>[389]</sup>. New adjoining glazed pavilions with interior swimming pools opening on the living areas and gardens were also added. Dimitri himself was very much involved in the conceptual design of both projects. He was assisted by Sung for the design development, while Guillermo Perilla (b.1945) took over the contract documentation and construction supervision<sup>[390]</sup>.

The Nihon Residence, located at 10 Roxboro Avenue, Westmount, was transformed from a two-storey townhouse into a three-storey mansion<sup>[391]</sup>. The swimming pool pavilion was laid out on a rectangular plan with rounded corners. Providing a 19th century greenhouse atmosphere, it featured a continuous strip of patio doors and a fully glazed roof supported by an arcuated steel structure<sup>[392]</sup>.

Situated in Dorval, off Riverside Drive, the Canadian style Apache Residence underwent major transformations from an original country house into an expanded mansion with a new wing for swimming pool and exercise rooms<sup>[393]</sup>. Post-Modernist, contextualist and vernacular, its new rectangular pavilion featured a widely glazed envelope matching the existing house with a simple traditional two-side pitched roof. At its extremity and facing the garden, a semi-circular glazed annex provided a Post-Modern finishing touch to the otherwise standard building volume (fig. 99). Displaying a continuous strip of patio doors topped by hollow frame ornamental motifs, the small structure was crowned by a fully glazed semi-conical roof<sup>[394]</sup>.

By mid-1990, Dimitri Dimakopoulos & Partners were also commissioned by Norman Nerenberg, President of Ensar Consultants Ltd., to design a

**\$50 million Hotel Complex in Prague<sup>[395]</sup>. The project was developed for Cunard Hotel & Resorts Inc., an American firm acting as the Master of Works. Highly motivated, Dimitri undertook the site and program analysis, developing various conceptual options leading to a unique campus concept for a luxury hotel complex located in the historic district of the Mala Strana in Prague<sup>[396]</sup>. This old city quarter, designated as an heritage site by UNESCO, included very fine private residences, civic buildings and palaces set in proximity of a green belt park edging the banks of the Vlatva River<sup>[397]</sup>.**

**The Prague Hotel Complex concept was developed in coordination with citizens' committees, representatives of the City of Prague as well as local heritage consultants and authorities. It was conceived to integrate and enlarge several historic buildings within the existing scale of the immediate environment while preserving the original character of the magnificent site<sup>[398]</sup>. In respect to their architectural heritage value, these historical buildings would require preservation, restoration, renovation or retro-adaptation with new constructions built around them. The new hotel functions would be integrated into their old interiors<sup>[399]</sup>.**

**Townwards, a large quadrilateral including a 16th century monastery as well as an 18th century building formerly used by the Governmental Archives Department would be recycled as part of the hotel campus (fig. 100)<sup>[400]</sup>. Closer to the river and part of the new hotel additions, an old building having previously housed the Sokol Headquarters would be transformed into a reception hall, similarly to an adjacent linear structure recycled into a wing for conference rooms, restaurant and services<sup>[401]</sup>. On the shore of the river, the Sova Mill consisted in an old mill house with a gorgeous site to be developed<sup>[402]</sup>.**

Following preliminary studies, Dimitri and Wigglesworth went to Prague for a week to visit the site and present their project to the Mayor of Prague, the Sokol Director as well as various citizens committees. Returning to Montreal without a coordinated final agreement, they saw their project later abandoned by Cunard in 1991, following its decision to drop out from the hotel business<sup>[403]</sup>.

This was the first and last major commission awarded to Dimitri Dimakopoulos & Partners during the decade of the 1990's. While large projects were getting rarer, the Prague Hotel Complex project was followed during the next three years by a short series of secondary projects<sup>[404]</sup>. It included the Montreal Olympic Stadium New Fixed Roof Project, 1992, by Blouin Dimakopoulos Boutros & Associés, featuring an elaborate engineering study and submission on which Dimitri participated. It also included the \$3.4 million Rivière-des-Prairies Primary School, by Dimitri Dimakopoulos & Associés, a new school for the PSBGM in which Dimitri himself had minimal involvement<sup>[405]</sup>.

Following a period of progressive health deterioration, Dimitri was operated at the Royal Victoria Hospital on December 19, 1992 and identified with a generalized cancer<sup>[406]</sup>. This operation was followed by a 6-month treatment during which he gradually reduced his visits to the office, staying at home most of the time.

In March 1993, Willy Sung left Dimitri Dimakopoulos & Partners following an excellent job offer in the Republic of China<sup>[407]</sup>. Later in the spring, it was decided by Dimitri and Wigglesworth that Dimitri Dimakopoulos & Partners would move into smaller premises to reduce losses. With the expiration of their lease on June 30, 1993, Wigglesworth proceeded to



move the office to 5423 de Lorimier Avenue, Suite #105, Montreal, a smaller and cheaper premise rented from the architect André Blouin (b.1920)<sup>[408]</sup>.

By August 1993, Dimitri decided to become a consultant and Wigglesworth completely took over the management and proprietorship of the firm, changing its name to Dimakopoulos Wigglesworth Architectes and carrying mainly two commissions<sup>[409]</sup>. For a year, Dimitri went into remission, his cancer being no longer evident. During that year, he did little work, coming only to the office on occasions<sup>[410]</sup>. Pursuing his cancer treatment, he became better for a while. Wigglesworth was able to see him a little more frequently but his health deteriorated once again in the summer of 1994. He was left with 15 months of unproductive life, residing in his home on Clarke Avenue until his death. During that period, he stayed in bed, assisted by his wife, two daughters and son-in-law<sup>[411]</sup>.

On August 14, 1995, Lydia was suddenly struck by a cerebral hemorrhage. She was brought to the Royal Victoria Hospital, where she stayed in the coma for three days before dying on August 17, 1995<sup>[412]</sup>. Seeing Dimitri at her funeral, Wigglesworth could hardly recognize him. A couple of days before the end, Dimitri was finally admitted at the Royal Victoria Hospital where he died peacefully on November 7, 1995<sup>[413]</sup>. His funeral was held on November 10, 1995 at the Saint Peter and Saint Paul Russian Orthodox Cathedral, 1151 Champlain Street, Montreal<sup>[414]</sup>.

Following his death, David Wigglesworth pursued the management of Dimakopoulos Wigglesworth Architectes until 1997, the last project of the firm being the \$0.75 million Stasiak Residence, Westmount, 1996-97, designed and implemented by himself<sup>[415]</sup>.

## CONCLUSION

Due to his outstanding career in Montreal, Dimitri Dimakopoulos must be considered as a dominant figure in Canadian and Quebec architectural history. Following the remarkable achievements of Thomas Baillargé (1791-1859) and Victor Bourgeau in the Province of Quebec during the nineteenth century, the Montreal-based Edward and William S. Maxwell became by the turn of the century the leading Canadian architects for a period of more than twenty years<sup>[1]</sup>. They were followed by the no less talented J. Omer Marchand and Ernest Cormier (1885-1980) who became their true successors during the first half of the twentieth century. I would argue that Dimitri Dimakopoulos joins this lineage for the next fifty-year period<sup>[2]</sup>.

From 1955 to 1995, Dimakopoulos pursued a career which established him as one of the five best architectural designers in Canada, joining Arthur Erickson, Eberhard Zeidler, Raymond Moriyama and Moshe Safdie<sup>[3]</sup>. During the same period, he also became the greatest architect practicing in Quebec<sup>[4]</sup>. Following his enrolment with the Province of Quebec Association of Architects in 1957, he became a member of many Canadian associations and committees and received a series of honorific nominations<sup>[5]</sup>.

In his earlier career with ARCOP, Dimitri was responsible with his partners for some of the best Canadian architectural achievements of the period. He should be firstly remembered for the Queen Elizabeth Theatre in Vancouver but even more importantly for the Fathers of Confederation Memorial Building in Charlottetown, a Modernist landmark speaking eloquently for itself.

During that period, Dimitri was a very inventive designer and his best

epoch lasted until 1975<sup>[6]</sup>. Although featuring many important projects and buildings, his Late and Post-Modernist phases were not nearly as bold, original and pristine as his original “Modern” Classical period. This was due in part to the fact that he could not insure complete control over his designs and was often requested by his clients to undertake major modifications<sup>[7]</sup>. His later career within his own firm, lasting nearly twenty years, would however follow a formidable development. Through the years, he would reaffirm his persistent leadership on the Montreal and Quebec scenes and be recognized locally as an architect with a particular status.

Dimitri Dimakopoulos could never be compared in importance to the greatest historical figures of architecture such as Andrea Palladio (1508-80), Gianlorenzo Bernini (1598-1680) or Ange-Jacques Gabriel (1698-1782)<sup>[8]</sup>. However a few comparisons may be traced in relation with some of these ancient art historical figures. Like Dhomnikos Theotokopoulos (Chania, 1541 - Toledo, 1614), more commonly known as El Greco, Dimitri Dimakopoulos was an outstanding Greek-born visual artist who moved from Greece to a remote Western country in order to practise his art. A Modern architect who lived 400 years after the Mannerist painter, he left some remarkable buildings in Montreal, Quebec and Canada instead of extraordinary Mannerist paintings in Toledo and Spain<sup>[9]</sup>.

Considering architecture as the "Mother of the Arts", Dimitri Dimakopoulos saw the architect as a person of great moral nobility and responsibility towards society<sup>[10]</sup>. Struggling to live as an artist-architect, he used his architectural office as a vehicle for his creativity. Similarly to Michelangelo Buonarotti (1475-1564) attacking the stone to discover the hidden sculpture into it, Dimitri would use the architectural programs of his

buildings to define an envelope from which a true piece of art could be derived<sup>[11]</sup>. Like Andrea Palladio (1508-80), he would be fascinated by numbers, ratios and scales. Translated in modern terms, his classicizing architecture would display a similar Classical restraint and harmony in proportions<sup>[12]</sup>.

To a lesser extent, Dimitri is also comparable to the famous nineteenth century French architect Charles Garnier (1825-1898) who launched his outstanding career with a Grand Prix de Rome for his 1848 graduation<sup>[13]</sup>. Thirteen years later, he would win the most important architectural competition held in France during the Romantic Period. The most important monument built during the Second Empire, the Opéra de Paris, 1861-75, remained one of the greatest French achievements in architecture. Pursuing a remarkable career until his death, Garnier became later considered as the greatest French architect of the nineteenth century and the last "Son of the Renaissance"<sup>[14]</sup>. In some aspects, Dimitri Dimakopoulos could be compared to him since he was the winner of two consecutive national competitions in Canada. While the first immediately followed his 1955 graduation, the Fathers of Confederation Memorial Buildings National Competition was one of the most important in twentieth century Canadian architectural history. Similar to Charles Garnier, he would also enjoy an outstanding career which lasted until his death but his fame would not spread internationally.

From a contemporary point of view, Dimitri will never equal in importance the "Great Masters of Modern Architecture" such as Frank Lloyd Wright, Mies van der Rohe and Le Corbusier. However, following an early Miesian influence, he developed like Le Corbusier a strong feeling for sculatural formalism, being fascinated by the juxtaposition of tectonic forms

fitting perfectly well together. Recognizing the virtue of urban monumentality whenever appropriate, he understood very well the urban fabric requirements and was much concerned with the placement and imagery of major civic buildings within the city<sup>[15]</sup>.

Of lesser importance than late twentieth century masters such as Ieoh Ming Pei, Philip Johnson and Robert Venturi (b.1925), Dimitri Dimakopoulos never attained the international status of many other foreign competitors<sup>[16]</sup>. Although very well known in Montreal, Quebec and Canada, Dimitri never reached architectural stardom, the most successful Canadians in that field being Arthur Erickson and Moshe Safdie. Dimitri was never too preoccupied by international recognition. His projects were rarely published in the foreign architectural press, although had they been he undoubtedly would have gathered more fame and commissions. Mostly concerned with the acquisition of local commissions to earn his living, Dimitri would obtain on occasions some foreign mandates from Greece, Saudi Arabia or China through personal contacts, allowing him to be active on the international scene<sup>[17]</sup>.

Eclectic like Philip Johnson, he would design buildings in the Modern, Late and Post-Modern modes, integrating on occasions some Structuralist, Sculpturalist or Classicizing concerns. Influenced like Johnson by the Post-Modern contemporary trends, he would adopt a "Free-Style" rather than a traditionalist Classicism<sup>[18]</sup>.

Originally driven by a Modern Functionalist impulse clearly expressed in his first project through Miesian/Johnsonian influences, his architecture soon became Classicizing, Sculpturalist and Structuralist, following a personal Modern Formalist mode displaying on occasions his Greek and

**Mediterranean roots<sup>[19]</sup>. Later in life, he became boldly associated with the Late-Modern and Post-Modern movements through the use of architectonic characteristics including new compositional devices and specific vocabularies of forms, details and materials<sup>[20]</sup>.**

**Similarly to Erickson, Zeidler and Safdie, Dimitri evolved from High to Post-Modernism, adapting his personal style to the new trends developing internationally in architectural design and technology during the 1970-80's, forcing him to adopt a revised stylistic attitude<sup>[21]</sup>. In essence, conservative, Modern and Classical rather than progressive and Avant-Guarde, Dimitri was late to adapt to fashionable new trends and he acted more as a follower than an initiator.**

**Responding to the new developments, Dimitri's architecture became more and more articulated and sophisticated, offering in some ways greater visual excitement<sup>[22]</sup>. He would tend to develop expressive designs of an highly personal nature in terms of style and signature, rejecting most of the time pastiche and imitation.**

**Basically a strong contextualist, he always evolved his designs from environmental, socio-cultural and urban design concerns, using a standard quasi-scientific design methodology based on program and site analysis, elaboration of optional concepts appraised through criteria evaluation leading to the selection of a final concept<sup>[23]</sup>.**

**His design work, based on a profound investigation and understanding of the program, followed an extremely analytic approach never stylistically pre-conceived. Fascinated by the program in which he foresaw the building design envelope, he would embrace various solutions, taking into consideration all aspects and needs and then selecting the best option<sup>[24]</sup>.**

Dimitri was driven by reason rather than emotion. He was implacably logical, his design approach being reasonable and realistic, pragmatic and scientific. His contextual work, mainly derived from program requirements and site constraints, would contain other inputs varying from functional and practical concerns to formal and geometrical concepts that could even become symbolical or spiritual on occasions<sup>[25]</sup>. When designing, he would always answer all criteria, developing his architectonic concepts from inspiration<sup>[26]</sup>.

He would achieve a synthesis in built form which had completeness and logic, answering all the program demands in a brilliant way. Much more an Internationalist than a Regionalist, Dimitri was also an Empirist and a Populist, very concerned with people's use. Encouraging verbal exchange between his building users, he would regularly add intimate spaces for such purposes in many of his projects<sup>[27]</sup>.

Dimitri, favouring team work through brain storming sessions, usually shared with his partners, associates and employees the conception of his projects. The subsequent preliminary design was developed by others, under his leadership and supervision, within his own firm and under his authorship and signature.

Enjoying working for important or rich patrons, Dimitri felt much more comfortable receiving commissions rather than aggressively pursuing opportunities. Since they were rare, Dimitri tended to operate in consortia in order to reduce the competition on larger projects. With little interest in posthumous recognition, Dimitri gave great importance to his architectural design reputation which allowed him to maintain his design office in operation. He basically enjoyed what he was doing at work and his driving

motivation was found in his architectural practice. Temperamentally not a salesman, he was not attracted by business, having difficulties promoting himself and ignoring the most lucrative aspects of his profession<sup>[28]</sup>.

Teamwork and brain storming were for him the only way to work. Trying to keep the ARCOP original design approach involving five equal partners, Dimitri evolved differently after the opening of his own firm, preferring the collaboration of junior partners, associates and employees<sup>[29]</sup>. He would supervise other people's works, drawing explanatory sketches with felt pens on occasions.

Fundamentally a leader, he had to be the only boss of his firm. Not too concerned with business administration and project implementation, he tended to specialize in design and conceptualization. Always initiating the projects by himself, he usually seconded the plastic and graphic design development to Willy Sung while the project administration would go to David Wigglesworth<sup>[30]</sup>.

Dimitri spent a lot of time on design with no consideration for expenses, and was never motivated by financial profit, consistently ignoring fast lucrative practice. Acting more like a school teacher than a business manager, he would be detached from office administration, allowing much freedom to his co-workers<sup>[31]</sup>. Following important client meetings, he would never hesitate to request important design changes regardless of profitability.

Always deeply involved with artwork integration into his projects, he would second perspective drawing and model making to Willy Sung who excelled in these tasks. Extremely meticulous and perfectionist, Dimitri would develop on occasions some artistic details by himself, expressing the



articulation and juxtaposition of forms. Interested in light and shade effects, he would rarely use a polychromatic treatment for his buildings<sup>[32]</sup>.

Of the humanitarian kind, Dimitri cared for those working with him, showing tremendous loyalty and scrupulous honesty. He would quickly appreciate talent, and sought to keep his staff permanently employed as much as possible. Uninterested in computer technology, he was forced to adapt his practice to new technological developments, remaining in essence an accomplished artist, skillfull free-hand sketcher, excellent draughtsman and highly creative designer<sup>[33]</sup>. His approach to architectural practice always focused on design, leaving contract documentation and construction supervision to others.

Specializing in architectural and urban design, his firm was involved through the years in a broad spectrum and wide variety of works, both in content and size, stimulating cross-fertilization in the development of ideas. From the prevailing influence of the Modern Movement during his early years, his search went far beyond it, keeping its essence present in his later projects<sup>[34]</sup>.

The development of his prolific career was relatively constant and progressive, based on flair, certitude and restraint. Devoid of pretension, Dimitri was very active in his career for nearly forty years, succeeding well in maintaining himself as a favoured architect. Having some difficulties to adapt with current socio-cultural and architectural developments, he would not accept public criticism very well, feeling more as an outsider in the French Canadian community<sup>[35]</sup>.

Divided between the Greek, English and French cultures, Dimitri operated a multi-cultural office where the Quebec Regionalist and vernacular

approach to architectural design was often absent. As a result, he was often struggling with the French Canadian community to have his projects publicly accepted by all<sup>[36]</sup>.

Proud and ambitious, Dimitri worked hard to maintain his prestige and recognition all his life. Very concerned with standing and decorum, he would always wear jacket and tie at work and his house would be impeccably furnished<sup>[37]</sup>. Attaching much importance to integrity and merit, he was an extremely honest, highly minded, moral and intransigent individual who was never driven by vanity or arrogance, remaining deeply human, warm and considerate with his colleagues<sup>[38]</sup>.

Dimitri Dimakopoulos has never received from the Quebec and Canadian societies the recognition that he deserved at the end of life. Except for a few short newspaper articles, no published or exhibited retrospectives of his outstanding career were ever made<sup>[39]</sup>. In Montreal, Quebec and Canada, Dimitri's memory will always survive for his outstanding achievements visible through a multiplicity of architectural landmarks. Like Maurice Richard (1921-2000) in hockey, he demonstrated that he was one of the best in his field and will remain extremely difficult to surpass.

## ENDNOTES

### PART ONE

- [1] Marie-Claude Lamoureux, Order of Architects of Quebec, telephone conversation, 8 Dec. 1999.
- [2] Constantine Economou, friend of the Dimakopoulos family, letter to the author, 8 Dec. 1999.
- [3] Grace Matthews, friend of the Dimakopoulos family, telephone conversation, 8 Dec. 1999.
- [4] Sophie Phocas Pashalis, niece of Dimitri Dimakopoulos, answers to questionnaire written on 6 Jan. 2000.
- [5] Robert Boulanger, Grèce. Les Guides Bleus (Paris: Librairie Hachette, 1967) 61.
- [6] Boulanger 61.
- [7] Sophie Phocas Pashalis.
- [8] Boulanger 61.
- [9] Grace Matthews, answers to questionnaire written on 8 Dec. 1999.
- [10] Gérard Leblanc, "Les Grecs dans la région de Montréal. Dimitri Dimakopoulos arrivé en 1948," La Presse 14 Nov. 1991.
- [11] McGill University, McGill University Calendar 1949-50; Faculty of Engineering 1949-50. (Montreal: McGill University Press, 1949) 1422. See: 1 Architecture.
- [12] McGill University, McGill University Calendar 1953-54, Faculty of Engineering 1953-54. (Montreal: McGill University Press, 1953) 1447-1451. See: Course of Instruction; School of Architecture.
- [13] McGill University, McGill University Calendar 1951-52, Faculty of Engineering 1951-52. (Montreal: McGill University Press, 1951) 1446-1451. See: Course of Instruction; School of Architecture. Graduated from McGill in 1927, Hazen Sise studied at M.I.T. before apprenticing himself to Le Corbusier. From 1931 to 1936, he worked for Howe & Lescaze in Philadelphia, Alfred Agache in Paris, and Adams Thompson Fry in London, participating to two major exhibitions and the 1933 CIAM gathering in Athens. Norman Bethune's ambulance driver during the Spanish civil war, he became the Canadian delegate to CIAM from 1936 to 1950. Between 1941 and 1949, he worked for

the National Film Board before starting teaching at McGill in 1950.

As a visiting teacher, Guy Desbarats (b.1925) also supervised from 1953 a construction laboratory course at the Centre de formation des hommes de métier, in the eastern part of Montreal. Concerned with full size work in brick, wood, steel, etc., it included a project for an Arctic house-pavilion dealing with permafrost conditions.

Graduated from McGill and winning the Anglin-Norcross, Hobbs Class Prizes and RAIC Medal in 1948, Desbarats had worked four years for Abra Balharrie and Shore in Ottawa before going to Europe with Gordon Webber and Arthur Erickson in 1952. He then started teaching at McGill. See: *The Canadian Architect*, "Odds and Ends," *The Canadian Architect* (December 1958): 10.

[14] Constantine Economou.

[15] McGill University, *McGill University Calendar 1949-50, Faculty of Engineering 1949-50*. (Montreal: McGill University Press, 1950) 1422-23, 1446. This course included lettering, orthographic projections, pictorial representation, perspective and experimentation in various drawing mediums. For that course, Dimakopoulos made a drawing of a chair built of wooden parts, displaying structural and aesthetic integrity.

[16] Constantine Economou. Later, from July 1953 to 54, he resided at 1336 Greene Ave., and from July 1954 to 55, at 246 Elm Ave., before moving to 4360 Décarie Blvd.

[17] Leonard Warshaw, former McGill architectural student in Dimakopoulos' class, telephone conversation, 9 Dec. 1999. The school was made of two building parts constituted by two attached houses. On the ground floor was found the secretariat and lecture room while wood and model workshops, storage, lounge, café and kitchenette were located in the basement. Located on the first floor, John Bland's office was followed by Lebensold's next to him, Spence Sales' being further at the back with the exhibition room for student projects. The second, third and fourth floors all included drawing workshops and small teacher offices. Similar on each floor, the building plan featured a large workshop on one side and a small corridor leading to two or three smaller rooms.

[18] McGill University, *McGill University Calendar 1951-52, Faculty of Engineering 1951-52* (Montreal McGill University Press, 1951) 1447.

[19] Marina Dimakopoulos, Dimakopoulos' younger daughter, answers to questionnaire

written on 6 Jan. 2000.

[20] McGill University, McGill University Calendar 1952-53, Faculty of Engineering 1952-53 (Montreal: McGill University Press, 1952) 1448.

[21] Gordon Edwards, former McGill architectural student graduated in 1954, telephone conversation, 9 Dec. 1999.

[22] Monte T. Swartzman, former McGill architectural student in Dimakopoulos' class, telephone conversation, 17 Dec. 1999.

[23] McGill University, McGill University Calendar 1953-54, Faculty of Engineering 1953-54 (Montreal: McGill University Press, 1953) 1450.

[24] Monte T. Swartzman. Monte and Ron Matthews were the other students.

[25] Marina Dimakopoulos.

[26] McGill University, McGill University Calendar 1954-55, Faculty of Engineering 1954-55 (Montreal: McGill University Press, 1954) 1451. A student trip was also organized to visit the influential Glass House, New Canaan, 1949, by Philip Johnson.

[27] Norbert Schoenauer, former McGill architectural student, associated consultant with ARCOP and McGill teacher, telephone conversation, 8 Dec. 1999.

[28] See the model photograph for the Civic Auditorium for Vancouver project designed by Dimitri Dimakopoulos and preserved with the archives of Affleck Desbarats Dimakopoulos Lebensold Michaud Sise Architects (Fonds A.D.D.L.S.) at the Bibliothèque nationale du Québec. It was made by Ron Matthews and Monte Swartzman.

[29] See "Vancouver's Civic Center and Auditorium Competition," The Canadian Architect, May 1956, 18-23.

[30] See the 8 sketch drawings of the Civic Auditorium for Vancouver project by lebensold . affleck . desbarats . michaud . sise architects, stamped Nov. 20, 1955 and preserved at the Bibliothèque nationale du Québec, in the A.D.D.L.M.S. Archives.

[31] Comment from David Wigglesworth, former associate in the firm Dimitri Dimakopoulos and Associates, reported in "Celebrated Architect designed many of Montreal's downtown landmarks," The Gazette, November 9, 1995: A 5.

[32] See "Vancouver's Civic Center and Auditorium Competition," The Canadian Architect, May 1956, 18-23. Prof. Fred Lasserre, head of University of British Columbia's

School of Architecture and former teacher at McGill University, Eero Saarinen (1910-61), prominent American architect of the period working in the Modern Functionalist and Formalist modes, and G. Sutton-Brown, city's planning director, were the three assessors with power to vote. Lasserre was also professional advisor to the city for the organization of the competition.

[33] See "Vancouver's Civic Center and Auditorium Competition," The Canadian Architect, May 1956, 18-23.

[34] See "Vancouver's Civic Center and Auditorium Competition," The Canadian Architect, May 1956, 18-23.

[35] Leonard Warshaw, former McGill architectural student in Dimakopoulos' class and winner of the second highest standing graduating student award after Harry Vandelman, telephone conversation, 9 Dec 1999.

## ENDNOTES

### PART TWO

- [1] John Bland, "Ray Affleck and the McGill School of Architecture," Architecture Québec ARQ No.34 Dec. 1986: 10. For his 1947 graduation, Affleck won the McLennan Scholarship permitting him to travel to Europe. Choosing Fred Lasserre's old school in Switzerland, he enrolled at the Zurich Polytechnic Institute for his graduate studies, working afterwards at the office of the former instructor Karl Moser (1860-1936) called Haeffli, Moser and Steiger. Back in Montreal, he first found a job at McDougall Smith and Fleming, a firm specializing in hospital design, where he met Hazen Sise. He then moved on to work at Vincent Rother's office where he probably met Fred Lebensold.
- [2] Guy Desbarats, Three views on architecture (Georgeville: manuscript, 2000). The client was the Department of Public Works (DPW) and Desbarats mainly worked on the interior details. They later won a Massey medal.
- [3] "City of Ottawa Police Building Competition". Journal RAIC (March 1955): 91-4. The 3rd award was valued \$300. The 4th award of \$200 was won by Fred Lebensold. Both also worked simultaneously on other personal commissions.
- [4] Montreal Yellow Pages (Montreal: Bell Canada, 1953, 1954).
- [5] "Beaver Lake Pavilion, Montreal." The Canadian Architect (December 1958) 42-7. Dimakopoulos did a perspective for Desbarats. The construction supervision was completed by Monte Swartzman in mid-1956. It won a Massey award.
- [6] Guy Desbarats, answers to questionnaire written on April 30th, 2000.
- [7] Guy Desbarats, answers to questionnaire.
- [8] Guy Desbarats, Three views. The Malmö City Theatre was constructed in 1944 by the Swedish architects Helldén, Lallerstedt and Lewerentz.
- [9] The fancy textured surface ornamentation included a vertical relief pattern in the exposed concrete of the auditorium and stage theatre large roof masses, a perforated expanded metal guardrail for the front upper foyer balcony, some vertically louvered windows for the annexed restaurant and a building exterior faience veneer.
- [10] "Vancouver Civic Auditorium. Eight views. First prize." The Canadian Architect (May 1956): 22.

- [11] “QE. The Queen Elizabeth Theatre.” The Canadian Architect (January 1960): 51.
- [12] Guy Desbarats, Three views.
- [13] Guy Desbarats, Three views.
- [14] “Projet primé de la salle de concert de Vancouver.” Architecture - Bâtiment - Construction (August 1955): 30-32.
- [15] “Les Nominations 1985 - Dimakopoulos Chevalier (1985).” Http://www.cex.gouv.qc.ca/ordre/86 (1986). This curriculum vitae was published on the web.
- [16] McGill University Calendar 1954-55, Faculty of Engineering 1954-55. (Montreal: McGill University Press, 1954) 1448. According to article 830: “Before a degree is granted a student must have had at least six months’ experience satisfactory to Faculty”.
- [17] “Vancouver Civic Auditorium. Eight views. First prize.” 22.
- [18] Marie-Claude Lamoureux, Order of Architects of Quebec, telephone conversation, December 8, 1999.
- [19] Vancouver Civic Auditorium. Eight views. First prize.” 22.
- [20] Guy Desbarats, Three views. At that time, ARCOP had hired some very able staff and Arthur B. Nichol became more closely associated with the project. The contract documentation included the architectural working drawings and specifications, complemented as usual by structural, mechanical and electrical engineering documents.
- [21] Guy Desbarats, Three views. The acoustical consultants were Bolt, Beranek & Newman Inc.
- [22] Arthur B. Nichol, answer to questionnaire sent on April 30, 2000.
- [23] Arthur B. Nichol. As per the ARCOP’s drawing archives preserved at the Bibliothèque nationale du Québec (Project No. 58-11), some construction drawings were issued as late as May 1962.
- [24] Goldschmidt, Nicholas, “The musician's view.” The Canadian Architect (January 1960) 58-59. Guy Desbarats was there.
- [25] “QE. The Queen Elizabeth Theatre. The background, the competition, the building.” The Canadian Architect (Jan. 1960) 53. By then, the building cost was \$5 million.



- [26] Monte T. Swartzman, telephone conversation, December 17, 1999. The latter worked at least six months on Dimakopoulos' project. As recalled by Arthur Nichol: "the Q.E.T. and the Drummond Plaza took up practically all Dimakopoulos' time".
- [27] Kimon Caragianis and wife, telephone conversation, early October 2000. The Greek Canadian owner and contractor had a son-in-law Peter who knew Dimakopoulos. He was asked to design the building whose registered architect was Roland Dumais.
- [28] Robert Lemire and Monique Trépanier, Inventory of buildings constructed between 1919 and 1959 in old Montreal and Saint-Georges and Saint-André wards (Ottawa: Ministry of Supplies and Services, 1981) 197. Located at 3435 Drummond Ave., the Drummond Plaza is referred as the "Maison de rapport Leicester Investment".
- [29] Robert Lemire and Monique Trépanier 197.
- [30] Grace Matthews, answers to questionnaire written on January 7, 2000. According to the July 1956 Bell Telephone directory and the PQAA records dating from December 14, 1956, they were listed at that precise new address.
- [31] Irene Dimakopoulos, answers to questionnaire written on May 4, 2000.
- [32] Beatified by the Greek Orthodox church, Saint Irene (752-803) was a Byzantine empress who organized the council of Nicée (787) and reestablished the cult of icons. Irene was also the name of three other saints who lived from the first to the seventh century AD.
- [33] John Bland, "Ray Affleck and the McGill School of Architecture," Architecture Québec ARQ No.34 Dec. 1986: 11. In early 1958, Dimakopoulos also worked with Affleck and Desbarats on competition schemes such as a Drive-in restaurant and a Restaurant for Vistarchi Building Corp. in Dorval, both published in the Journal RAIC, May and June 1958, 183 and 237. Both projects displayed Johnsonian characteristics derived from Mies van der Rohe. They featured low rectangular semi-glazed boxes with steel structures, complemented by exterior light weight free-standing elements.
- [34] Arthur B. Nichol, answers to questionnaire written on April 30, 2000. The September 1958 Bell Telephone Directory confirms that change of address as well as the BNQ archive drawings (project 58-11).
- [35] Fred Lebensold, "Place des Arts, Montreal, P.Q." The Canadian Architect

(November 1963): 48. The “bombshell - Place Ville-Marie” quotation originates from Guy Desbarats’ Three views.

[36] Kimon Caragianis, telephone conversation, October 9, 2000.

[37] Guy Desbarats, Three views.

[38] Guy Desbarats, Three views.

[39] Hans Stenman, answers to questionnaire written on April 30, 2000. See also Guy Desbarats’s Three views.

[40] Guy Desbarats, Three views. The whole group had a left of centre reputation and Hazen Sise was known as the former ambulance driver of Norman Bethune (1890-1939) during the 1936 Spanish civil war.

[41] François Rémillard and Brian Merrett, L’architecture de Montréal. Guide des styles et des bâtiments (Montreal: Editions du Méridien, 1990) 186.

[42] Hans Stenman, answers to questionnaire written on April 30, 2000.

[43] Hans Stenman.

[44] Leonard L. Knott, La Place (Montreal: Rolph, Clark, Stone, Benallack, Limited, 1962) 72.

[45] Hans Stenman.

[46] “New life flows into heart of city,” The Gazette 12 Sep. 1962: 22.

[47] Hans Stenman.

[48] Monte Swartzman, telephone conversation, December 19, 1999. From March 1957 and through 1958, Swartzman acted as ARCOP representative and liaison in New York City.

[49] “Place Ville Marie \$80-million city within a city. City’s new business district,” The Montreal Star 12 Sep. 1962: 38.

[50] Guy Desbarats, Three views.

[51] “Imperial Oil plaza tenant,” The Gazette 13 Sep. 1962: 30. Originally, its name was Imperial Oil Building and the company rented 50,000 square feet.

[52] “Place Ville Marie: A bird’s eye-view,” The Montreal Star 11 Sep. 1962: 11.

[53] “Imperial Oil plaza tenant.” On Cathcart, the building had originally five storeys. It was later expanded with two upper storeys in 1968, similarly to the Richardson

Greenshields Building originally completed in 1963. As for the IBM Building, it was initially completed in 1967 with 13 storeys and later expanded with four extra storeys in 1980. At that time, the overall cost of Place Ville Marie was over \$116 million. Later, from Fall 1986 to Fall 1988, Trizec Corporation proceeded with a \$40-million renovation project with the architects I. M. Pei & Associates and Arcop Associates. This project featured a new pedestrian entrance, corner University and Cathcart, the tower complete refenestration, the reorganization of the office and commercial spaces, the transformation of the elevators, entrance and elevator halls, public spaces and washrooms, the renovation of the shopping promenade, underground parking and plaza central court including lawns, tree plantations, glazed roofed stairs, etc. See Bâtiment (Nov-Dec 1986) 16-17.

[54] Charles Lazarus, "Place Ville Marie opened officially," The Montreal Star 14 Sep. 1962: Section II, 1.

[55] Charles Lazarus, "Place Ville Marie to get addition within 12 months," The Montreal Star 13 September 1962: 1. This article referred specifically to the IBM Building.

[56] As per Fred Lebensold's "Place des Arts, Montreal, P.Q.", the preliminary masterplan was completed in 1959. It was first published in "Place des Arts. Etudes d'avant-projet pour un centre", Architecture - Bâtiment - Construction (January 1959): 28-32. As per Desbarats' answers to questionnaire written on April 30, 2000, it was finally completed after the design of the Grande Salle. Since it was ARCOP's own initiative, they were never paid for it.

[57] Place des Arts . On February 2, 1956, a royal assent was given to the act of the establishment and operation for a concert hall in Montreal (Bill 25). On March 15, 1956, letters patent were granted to the Sir George-Etienne Cartier Corporation.

[58] Guy Desbarats, Three views.

[59] Guy Desbarats, Three views.

[60] Guy Desbarats, Three views.

[61] "Place des Arts. Etudes d'avant-projet pour un centre," Architecture - Bâtiment - Construction (January 1959): 28.

[62] Guy Desbarats, Three views.

- [63] Guy Desbarats, first interview in Georgeville on September 25, 2000. See also Three views.
- [64] Guy Desbarats, first interview.
- [65] “Place des Arts. Etudes d’avant-projet pour un centre”: 28-32.
- [66] Fred Lebensold 48. With a similar quasi-symmetrical opened plaza, the Modernist Classical tripartite composition could be compared to that of the Lincoln Center, New York, 1958-66, by Abramovitz, Johnson and Harrison, built during the same period in another large north-east American metropolis.
- [67] “Place des Arts. Etudes d’avant-projet pour un centre”: 31.
- [68] “Place des Arts. Etudes d’avant-projet pour un centre”: 31.
- [69] Eva Vecsei, telephone conversation, April 7, 2000.
- [70] Eva Vecsei. According to Guy Desbarats’ Three views, Bill Snaith was the president and project representative for the Raymond Loewy Corporation.
- [71] Arthur B. Nichol, answers to questionnaire written on April 30, 2000.
- [72] Guy Desbarats, Three views.
- [73] Architecture - Bâtiment - Construction 28-32.
- [74] Guy Desbarats, Three views.
- [75] Fred Lebensold 48.
- [76] Fred Lebensold 48.
- [77] Guy Desbarats, Three views.
- [78] Guy Desbarats, Three views. Desbarats’ unusual chandeliers design grew out from the core walls into the curved ceilings of the lobbies. After an uneasy acceptance by the board, he went to Venice where he met and finalized the details with the Venini Glass Works, the Venitian chandeliers makers selected by ARCOP.
- [79] Robert Ayre, “Place des Arts: the artists,” The Canadian Architect (November 1963): 62. The industrial designers Julien Hébert and Norman Slater also contributed “anonymously” to the artworks program. The former designed textured aluminum strips providing a lively decoration behind the stairs in the entrance lobby. The latter conceived the curtain wall aluminum screen made up of 8000 fins producing vertically elongated hollow hexagonal forms. This textural treatment was related to the vertical linear texture

of the precast walls.

[80] Eva Vecsei, telephone conversation, April 7, 2000.

[81] Guy Desbarats, Three views.

[82] Arthur B. Nichol and Hans Stenman, answers to questionnaire written on April 30, 2000.

[83] "Credits," The Canadian Architect (November 1963): 65. Henri Beaulac contributed to the interior finishes as "interiors' consultant". It was reported in "Grande Salle decor emphasizes simplicity," The Montreal Star 17 Sep. 1963, that he had been "responsible for almost all of the details of the 3000 seat hall's interior decoration."

[84] John Bland, "Place des Arts: A critical appraisal," The Canadian Architect (November 1963): 60.

[85] Place des Arts.

[86] "A family of new concert halls," The Montreal Star 17 Sep. 1963 : 9. Although the total cost was later reevaluated to \$25 million, it was at the time reported that the Place des Arts had cost \$23 million to that date. This included purchase of land, plaza, parking, Grande Salle, subway connections, etc. The building cost itself was reported in "Glittering opening night," The Gazette, 23 Sep. 1963. As per Guy Desbarats' Three views, the budget was not seriously blown.

[87] Guy Desbarats, Three views.

[88] Place des Arts.

[89] Eric McLean, "Our wonderful new hall!" The Montreal Star 23 Sep. 1963: 10.

[90] Eric McLean.

[91] Guy Desbarats, Three views.

[92] "Names of outstanding Canadians of 1964. Scene changers. Affleck, Desbarats, Dimakopoulos, Lebensold, Sise," Maclean's (January 2, 1965) : 11. The others were Elizabeth II, Ecumenist Father Gregory Baum, Athlete Plus Jean Béliveau and Integrator Paul Hellyer.

[93] "Massey Medals 1964," RAIC Journal (November 1964): 123.

[94] Between 1988 and 1992, Dimitri Dimakopoulos & Partners were also involved in a \$18-million renovation and expansion project for Salle Wilfrid Pelletier. The stage and

backstage areas were modified, including doubling of stage and wings, rehearsal room for dance, new dressing rooms and offices, reconfigured orchestra shell and pit, acoustical improvements, new stage equipment, elevators and enclosed truck dock. This project was soon followed by the \$10-million completion of Place des Arts quadrilateral between 1989 and 1993. Including new terraces, fountains, pools, waterfalls and landscaping, it transformed Place des Arts into a major civic centre. Providing direct communication from Ste-Catherine Street, the new museum and the theatre building, it also involved the reorganisation of the interior central foyer.

[95] Kimon Caragianis, telephone conversation, October 9, 2000.

[96] "Greek Orthodox Cathedral, Montreal," The Canadian Architect (August 1960): 42.

[97] Monte Swartzman, telephone conversation, December 17, 1999. Swartzman assisted Dimakopoulos on this rush project, producing drawings overnight during a "charette" session. During the summer of 1958, Jerry Miller, still an undergraduate, assisted Dimakopoulos on the design.

[98] As per the construction contract between Douglas Bremner Contractors & Builders Ltd. and The Hellenic Canadian Community of the Island of Montreal, September 19, 1959, as well as the Resolution of the Board of Governors of Hellenic-Canadian Community, January 19, 1959. These archives documents were consulted at the Hellenic Community of Montreal office. The final overall cost was \$2.5 million.

[99] Hellenic Community of Montreal, Brief history of the Hellenic Community of Montreal (Montreal: Hellenic Community of Montreal, 1997) 2.

[100] Guy Desbarats, Three views. Desbarats was the Partner-in-Charge for the St. Gérard Magella Church & Presbitery, St. Jean, PQ, 1959-63, and the St. Thomas Aquinas Church competition, St. Lambert, PQ, 1963-67, like Lebensold was for the Tifereth Jerusalem Synagogue, Côte-St-Luc, Montreal, 1963-4, all by ADDLS. All these churches won Massey awards.

[101] Patrick Schupp, "Pro-cathédrale St-Georges de la communauté grecque de Montréal," Architecture - Bâtiment - Construction (March 1962): 32.

[102] Patrick Schupp 32.

- [103] Peter Collins, "Orthodoxy," RAIC Journal, (December 1962): 67
- [104] Peter Collins 67.
- [105] Patrick Schupp 32.
- [106] Patrick Schupp 32.
- [107] Peter Collins 67-8.
- [108] Peter Collins 65-8.
- [109] Peter Collins 65-8. Known as the masterpiece of the Byzantine age (395-1453), Haghia Sophia, "Church of the Holly Wisdom", was a commission given by the Byzantine Emperor Justinian (482-567) to the architects Anthemius of Tralles and Isidore of Miletus who erected the largest domed structure ever built between 532 and 537. Drawing its inspiration from it, Frank Lloyd Wright's Greek Orthodox Church at Wauwatosa had the same dome diameter of 106 feet.
- [110] Guy Desbarats, Three views. Like all other ADDLMS partners, he shared the credit for the design of their teamwork projects.
- [111] Guy Desbarats, Three views. From a French Canadian commissioners point of view, Michaud provided some balance to ARCOP in representing with Desbarats the older French community. As per Affleck and Sise, they represented the English one while Lebensold and Dimakopoulos represented the newly arrived immigrants.
- [112] According to the Bell Canada Yellow Pages Montreal Directory, Jean Michaud was listed with ADDLMS at 1010 Ste-Catherine W. until September 1962 when his office address was changed to 2040 St-Matthieu. One year later, he had moved to 59 St. Jacques. As per the Bell Canada White Pages Montreal Directory, he was listed with the two first addresses in August 1962 until July 1963.
- [113] Irene Dimakopoulos, answers to questionnaire written on May 4, 2000.
- [114] Irene Dimakopoulos. In September 1961, Irene started nursery school in Westmount at St-Georges private school, remaining there until her Grade 11 graduation in June 1974. Marina followed in the same school in September 1965, graduating in June 1977.
- [115] According to the Bell Telephone Montreal Directory, they were listed at 6030 Côte St-Luc from July 1964 until August 1965, residing from that date at 5765 Côte St-Luc.

- [116] Irene Dimakopoulos.
- [117] "Entrepôt de Norman Wade Co. Ltd. à Pointe-Claire," Architecture - Bâtiment - Construction (Juin 1962): 33.
- [118] "Entrepôt de Norman Wade Co. Ltd. à Pointe-Claire." See also: Ken Giddings, "Better precast concrete," RAIC Journal (August 1963): 37.
- [119] "Massey Medals 1964," RAIC Journal (November 1964): 126.
- [120] "Norman Wade Building, Pointe Claire, P.Q.," The Canadian Architect (July 1963): 41
- [121] "Entrepôt de Norman Wade Co. Ltd. à Pointe-Claire."
- [122] "Massey Medals 1964": 126.
- [123] Guy Desbarats, Three views.
- [124] John Bland, telephone conversation, December 13, 1999.
- [125] Guy Desbarats, Three views.
- [126] "Summerlea Golf & Country Club, Pointe Cascades, P.Q.," The Canadian Architect (September 1963): 47.
- [127] "Summerlea Golf & Country Club": 48.
- [128] "Summerlea Golf & Country Club": 48.
- [129] "Competition: Fathers of Confederation Memorial Building for Charlottetown, P.E.I.," The Canadian Architect (March 1962): 57. See also: Douglas Shadbolt, "Confederation Centre," RAIC Journal (December 1964): 24.
- [130] Craig Brown et al, Histoire générale du Canada (Montreal: Editions du Boréal, 1988) 385.
- [131] Michelin Canada (Clermont-Ferrand: Michelin et Cie, 1994) 205.
- [132] "Competition" 57. See also Michelin Canada.
- [133] "Competition" 57. See also: Walter P. de Silva, "Fathers of Confederation. Memorial Buildings, Charlottetown. Critique," The Canadian Architect (November 1964) 50. Also: "Fathers of Confederation Memorial Building. Report of jury," RAIC Journal (February 1962) 32.
- [134] "Fathers of Confederation Memorial Building" 31. Sir Basil Spence was a British Modernist mainly known for his post-war Coventry Cathedral, a quasi-Gothic



traditional and Modern Structuralist compromise built in the 1950s.

[135] "Competition" 57.

[136] Guy Desbarats, Three views.

[137] Hans Stenman.

[138] Norbert Schoenauer, "Fathers of Confederation Memorial Building, Charlotte-town," The Canadian Architect (November 1964): 42-3.

[139] Guy Desbarats, Three views.

[140] Guy Desbarats, Three views.

[141] Guy Desbarats, Three views.

[142] Douglas Shadbolt 35. See also: The Canadian Architect, "Fathers of Confederation Memorial Building" 45.

[143] Walter P. de Silva 50.

[144] Affleck/Desbarats/Dimakopoulos/Lebensold/Sise, "Comments by the architects," RAIC Journal (December 1964): 21.

[145] The Canadian Architect, "Competition" 58.

[146] Walter P. de Silva 50. From a quotation of Peter Desbarats in The Montreal Star. Furthermore, the project was a remarkable Modernist achievement fore-running major Post-Modernist concerns such as architectural insertion and contextualism.

[147] Eva Vecsei. The other presentation drawings for the competition were made by Agnes Bagi.

[148] "Fathers of Confederation Memorial building. Report of Jury," 32. While the second prize was won by Mandel Sprachman, of Toronto, the third prize was shared by John Bland, Roy LeMoyne & Gordon Edwards, of Montreal, and Gordon L. Cheney, of Toronto. Mentions were also given to six firms including that of John B. Parkin, of Toronto.

[149] Raic Journal, "Fathers of Confederation Memorial Building. Report of jury," 33.

[150] Guy Desbarats, Three views.

[151] Guy Desbarats, Three views.

[152] Guy Desbarats, second interview in Georgeville on October 2nd, 2000.

[153] The Governor General was Georges Philéas Vanier (1888-1967).

[154] Guy Desbarats, second interview. See also: "Fathers of Confederation Memorial Building" 31.

[155] Hans Stenman.

[156] On February 2, 1963, the sod-turning took place with Honourable Robert J. Stanfield of Nova Scotia and Quebec Premier Jean Lesage gave an address at the table of the Fathers. Later in 1963, Prime Minister Lester B. Pearson (1897-1972) pronounced a speech at the laying of the cornerstone.

[157] Hans Stenman.

[158] "Fathers of Confederation Memorial Building, Charlottetown," RAIC Journal (December 1964) 19.

[159] Guy Desbarats, Three views.

[160] Hans Stenman. See also: "Fathers of Confederation Memorial Building, Charlottetown," RAIC Journal (December 1964) 19. While Prof. George Izenour was the theatre consultant, Bolt, Beranek & Newman were the American acoustical consultants.

[161] Guy Desbarats, Three views.

[162] Hans Stenman.

[163] Guy Desbarats, second interview.

[164] Guy Desbarats, second interview. Representing in perspective the Fathers of Confederation Memorial Buildings and centenary, the 5 cents grey stamp measured 2.5 x 3.8 cm. A similar commemorative medallion was also struck in 1964.

[165] Douglas Shadbolt 25.

[166] Guy Desbarats, second interview. See also: Douglas Shadbolt 25. First proposed in a brief by founder Dr. Frank MacKinnon to the Massey Commission on January 26, 1950, the Memorial was officially opened by the Queen, accompanied by Mr. MacKinnon, President of the Fathers of Confederation Memorial Citizen's Foundation, and Eric Harvie, Chairman of the board of directors.

[167] Guy Desbarats, second interview. It won a Massey medal in 1967.

[168] Hans Stenman. As per the ARCOP archives preserved at the Bibliothèque nationale du Québec under the project number BNQ 62-19.

- [169] Guy Desbarats, Three views.
- [170] Hans Stenman.
- [171] As per BNQ 62-19 archives (tube 02). See Plaza plan.
- [172] As per BNQ 62-19 archives (tube 02). See Administration Bldg. Floor plans.
- [173] As per BNQ 62-19 archives (tube 02). See Admin. Bldg. Elevations.
- [174] As per BNQ 62-19 archives (tube 02). See Admin. Bldg. Roof plan.
- [175] As per BNQ 62-19 archives (tube 02). See Health Centre. Floor plans.
- [176] As per BNQ 62-19 archives (tube 02). See Health Centre. Roof plan.
- [177] As per BNQ 62-19 archives (tube 02). See Health Centre. Elevations.
- [178] As per the Annual report of the Department of Public Works for the Province of Prince Edward Island for the year ended March 31st 1964, the tender was called in March 1964. The 1965 report stated that Thomas Fuller Construction (1958) Ltd. from Ottawa was awarded the contract and pursued protected construction works throughout winter. Connected at basement level, the twofold building complex was “almost unique” with its sandblasted structural concrete exterior finish. The 1966 report stated that completion was scheduled for fall while a foundation stone ceremony was held on July 30th, 1965 including placement of a bronze plaque. The 1967 report stated that occupancy of the Administration building took place in the early part of the year and that of the Health centre in December 1966.
- [179] Guy Desbarats, Three views. The final overall cost was \$8 million.
- [180] Guy Desbarats, Three views. The three Concordia partners were Norman Nerenberg, Arnold Issenman and Philip Coleman.
- [181] The selected site was delimited by University St., La Gauchetière St., Saint-Antoine St. and Mansfield Ave.
- [182] Guy Desbarats, Three views.
- [183] Hans Stenman.
- [184] Guy Desbarats, Three views.
- [185] Guy Desbarats, Three views.
- [186] Guy Desbarats, Three views.
- [187] Hans Stenman.

- [188] Eva Vecsei, answers to questionnaire written on April 30, 2000.
- [189] Eva Vecsei, telephone conversation, April 7, 2000.
- [190] Guy Desbarats, Three views. As per "Place Bonaventure, Montréal," Architecture - Bâtiment - Construction (December 1967) 13, Eva Vecsei was the composition architect, Daniel Lazosky and Hans Stenman, the project architects, J.E. Larivière, the project manager, and N. Holloway, the project administrator. Vincent Ponte was the town planning consultant. The \$85-million Place Bonaventure won a Massey medal in 1970.
- [191] Guy Desbarats, Three views.
- [192] Guy Desbarats, Three views. This concept was a proposal originating from Guy Desbarats.
- [193] "National Arts Center, Ottawa, Ontario," Architecture Canada. Massey Medals 1970 (October, 12 1970): 13.
- [194] "National Arts Center, Ottawa 1969. Architects: Affleck Desbarats Dimakopoulos Lebensold Sise," The Canadian Architect (November 1980): 35. The building displayed two types of contrasting concrete textures, one smooth, the other ribbed vertically.
- [195] "National Arts Center, Ottawa 1969. Architects: Affleck Desbarats Dimakopoulos Lebensold Sise" 35. The NAC complex final overall cost was \$55 million.
- [196] Guy Desbarats, Three views.
- [197] Guy Desbarats, Three views.
- [198] "Odds and Ends. Arts Centre," The Canadian Architect Sept. 1965: 5. Cummings and Campbell were associated architects on the project.
- [199] "Centre des arts et de la culture, St-Jean, Terre-Neuve," Architecture - Bâtiment - Construction (January 1967): 11.
- [200] Guy Desbarats, Three views. See also: "Odds and Ends. Arts Centre," The Canadian Architect (September 1965): 5.
- [201] Guy Desbarats, Three views and Eva Vecsei, answers to questionnaire written on April 30, 2000.
- [202] Guy Desbarats, Three views. The final overall cost was \$10.5 million.
- [203] Hans Stenman. See also: Bell Canada Montreal telephone directory, August

1966.

[204] Hans Stenman.

[205] David Wigglesworth, answers to questionnaire written on April 30, 2000.

[206] Guy Desbarats, second interview.

[207] Hans Stenman.

[208] Other “private” projects included Affleck and Lebensold’s own residences which turned out to be not so distinguished.

[209] Alain Marcoux, “Précisions sur le Brutalisme (1950-1970),” Le Journal d’Outremont (December 1995): 26.

[210] The sloping site treated with terraces, the use of organic materials such as brick, wood and glass, and the general mass and architectonic treatment of the house echoed the architectural design of the Civic Center, Säynätsalo, Finland, 1949-52, by Alvar Aalto (1898-1976).

[211] Guy Desbarats, Three views.

[212] Guy Desbarats, Three views.

[213] Irene Dimakopoulos, answers to questionnaire written on May 4, 2000.

[214] Irene Dimakopoulos.

[215] Irene Dimakopoulos and Hans Stenman.

[216] Irene Dimakopoulos. Bob Herman and Dan Franic assisted Dimakopoulos on the original project, while Wigglesworth helped him with later maintenance modifications.

[217] Irene Dimakopoulos.

[218] Irene Dimakopoulos.

[219] Irene Dimakopoulos.

[220] Guy Desbarats, Three views.

[221] Guy Desbarats, Three views. During his career, Dimakopoulos maintained some ties with universities as invited critic at McGill and Laval in 1960 and 64. In 1965, he became part time teacher, member of the Université de Montréal consultative architectural committee, as well as member of the PQAA exterior relations commission. From 1969 to 80, he was also invited professor at McGill University. See “Les Nominations 1985. Dimitri Dimakopoulos chevalier (1985) [Http: /www. cex. Gouv.qc.ca/Ordre/86/86](http://www.cex.gouv.qc.ca/Ordre/86/86). On

a more regular basis, Lebensold had been teaching Design Class B (5th year) at McGill in 1955-56. Sise had been teaching Architectural Report (4th year) and History of Modern Architecture (4th year) at McGill from 1955-6 to 1957-8. Desbarats had been teaching Building Construction (3rd and 4th year) at McGill from 1955-6 to 1958-9. Affleck had been teaching Design Class B (5th year) at McGill from 1956-7 to 1958-9. All too busy at the office in the 1960s, none were involved in regular teaching afterwards although all were invited at McGill at different times as visiting lecturers or critics.

[222] Guy Desbarats, Three views

[223] Guy Desbarats, Three views

[224] Guy Desbarats, Three views. By opposition to Dimakopoulos' Mediterranean approach, Desbarats was more concerned with Canadian regional context and historical sensibility. His model for a Canadian architectural identity was drawn from modesty, elegance, scale and inventiveness, while his main inspiration sources were found in Breuer, Aalto and other Finnish architects. On the contrary, Affleck was usually influenced by new international trends, evolving from Bauhaus Functionalism to Modern Monumentalism, Neo-Brutalism, Ad hoc architecture, In-fill restoration and Post-Modernism. His true nature was however simplicity and relaxed style.

[225] Guy Desbarats, Three views.

[226] Guy Desbarats, Three views.

[227] Guy Desbarats, Three views.

[228] Hans Stenman.

[229] "Comment Expo '70 Competition," The Canadian Architect (Aug. 1967): 29.

[230] "Comment Expo '67 Competition" 29.

[231] David Wigglesworth. Like Dimi for Dimitri, Willy preferred this diminutive.

[232] Guy Desbarats, Three views. See also: "Comment Expo'67 Competition," 38.

[233] "Comment Expo '67 Competition," 38.

[234] As per BNQ 67-19c archives. See presentation and preliminary drawings and title blocks. Carlo della Valle was the President of World Mosaic Ltd.

[235] As per BNQ 67-19c archives. See site plans.

[236] As per BNQ 67-19c archives. See floor plans.

[237] Hans Stenman.

[238] "Award. Life Sciences Building, Dalhousie University, Halifax, N.S. Architects: Affleck, Dimakopoulos, Lebensold. Associate Architect: C.D. Davidson & Co.," The Canadian Architect, Yearbook 1968 (1968): 54.

[239] Hans Stenman, Eva Vecsei and David Wigglesworth. According to Stenman, if Dimakopoulos was ever involved, it would have been only at the conceptual stage. According to Eva Vecsei, responsible for the design development, as well as Wigglesworth, who later joined the team as a job captain, Dimakopoulos was probably never involved at all, Affleck remaining the only Partner-in-charge of design. See: "Life Sciences Building, Dalhousie University, Halifax, N.S.," The Canadian Architect (February 1974): 30.

[240] Hans Stenman.

[241] Hans Stenman.

[242] Paul Gauthier et al, "Jean-Marie Roy." Architecture Québec ARQ No.36 (April 1987): 21, 26-7, 34. The protruding concrete pilaster treatment of the elevations proved to be Dimakopoulos' last echo of the Greek Classical colonnade.

[243] Hans Stenman. See also: "+15 Calgary. A Development plan for downtown." Architecture Canada November 1969:9-12. The architect-planner staff of Calgary's Planning Department, Harold Hanen, senior planner, Gordon Atkins and Jack Long, two Calgary consultants were part of the team.

[244] Dimakopoulos & Partners. Architecture & urban design. (Montreal: Dimakopoulos & Partners, c.1979): 5. See also: DWA. Dimakopoulos Wigglesworth Architectes (Montreal: Dimakopoulos Wigglesworth, 1995): Concours, prix et distinctions.

[245] "Award. College Montis Regii, Université de Montréal," The Canadian Architect 1969 Yearbook (1969): 54. The budget was \$4 million.

[246] "Award. College Montis Regii, Université de Montréal"54.

[247] "Hotel," The Canadian Architect (November 1969): 62.

[248] Hélène Gosselin-Geoffrion, "Hôtel Le Concorde, Québec," Architecture Concept (Nov./ Dec. 1974): 17. As per Eva Vecsei, she only played a minor role in the design development of the project. The corporate client was La Corporation de la Grande Allée.

- [249] "Hotel" 62.
- [250] "Hotel" 62.
- [251] "Perspective. Projects," The Canadian Architect (August 1972): 7. As per Stenman and Wigglesworth, the cost of the steel diagrid could not be resolved within the \$14-million budget. It was replaced by a cheaper structural concrete option. While the building volumetry arose from structural cantilevering concerns, the resulting design turned out to be very well integrated to the particular regional vernacular architecture of Quebec City. The overall final cost was \$22 million.
- [252] Hans Stenman, Eva Vecsei and David Wigglesworth, answers to questionnaire written on April 30, 2000. The estimated cost was \$40 million.
- [253] Eva Vecsei.
- [254] "Urban renewal," Architecture Canada (July 1970): 1.
- [255] Eva Vecsei.
- [256] Eva Vecsei.
- [257] Eva Vecsei.
- [258] "Projects," The Canadian Architect (August 1970): 8. This was mainly because of the inevitable loss of existing housing due to the magnitude of the project. Affleck had the feeling that the community was right and his client was wrong.
- [259] Eva Vecsei. After Affleck had invited Jane Jacobs to see the project and the existing urban environment of the area, he soon found out that she was also opposed to the project. This was the last straw.
- [260] Hans Stenman.
- [261] Hans Stenman.
- [262] Hans Stenman.
- [263] Guy Desbarats, Three views.
- [264] Guy Desbarats, Three views.
- [265] Hans Stenman.
- [266] Hans Stenman.



## ENDNOTES

### PART THREE

- [1] Hans Stenman, answers to questionnaire written on April 30, 2000.
- [2] Hans Stenman and Eva Vecsei, answers to questionnaire written on April 30, 2000.
- [3] Hans Stenman and Eva Vecsei.
- [4] Norman Pressman, "Anatomy of the pedestrian mall," The Canadian Architect (March 1971) : 54.
- [5] Eva Vecsei.
- [6] "Urban renewal," Architecture Canada (July 1970): 1.
- [7] Concordia Estates Limited, Cité Concordia (Montreal: Concordia Estates Ltd., 1970): Omnibuilding: act 1, L'Esplanade.
- [8] "Urban renewal": 2. In the first phase, 60 grey-stone townhouses, three churches, two schools and other buildings were to be preserved. The three churches included the St-John's Lutheran Church and the First Presbyterian Church, both on Jeanne Mance Street. Resulting from the fusion of the two former churches Saint-Gabriel and Chalmers, the latter was erected in 1910 at 3666 Jeanne Mance. Containing rich oak wood interior finishes, it was the oldest Presbyterian Church in Canada. See: Françoise Pitt, "La Cité, c'est la formule de l'avenir," Bâtiment (June 1975): 8.
- [9] Eva Vecsei. See also: "Projects," The Canadian Architect (August 1970): 9.
- [10] Concordia Estates Limited: action centres.
- [11] Hans Stenman
- [12] "Projects": 9
- [13] Hans Stenman.
- [14] Hans Stenman and Eva Vecsei.
- [15] Eva Vecsei and Alain Marcoux. As a 3rd year architectural student and apprentice introduced to Dimakopoulos by Guy Desbarats, I worked in his office from mid-April to late August 1972, getting in direct contact with him and witnessing the simultaneous development of the four major projects contemporary to Cité Concordia. The first two months were spent on conceptual studies for the Touristic Development of Tangier Bay International Architectural Competition, and the remaining period on the production

of graphics for the UQAM Masterplan. The earlier site study was initiated the year before by Dimitri heading a small team including Rein Kuris (b.1944) acting as design assistant.

[16] Eva Vecsei.

[17] Eva Vecsei, telephone conversation, December 14, 2000. See also: "Montreal's \$250 million Cité Concordia poised for early construction start," Canadian Building (December 1973): 19. At that point, the construction of the fourth scheme was scheduled to start later in the month.

[18] Françoise Pitt: 7-8.

[19] David Wigglesworth, answer to questionnaire written on April 30, 2000.

[20] David Wigglesworth.

[21] David Wigglesworth.

[22] Hans Stenman.

[23] Hans Stenman and David Wigglesworth.

[24] Hans Stenman, telephone conversation, November 10, 2000; David Wigglesworth, first interview in Montreal on December 2, 2000.

[25] David Wigglesworth, first interview.

[26] David Wigglesworth, first interview.

[27] Alain Marcoux and David Wigglesworth, second interview in Montreal, December 18, 2000. During the summer of 1972, both adjacent offices shared the same glazed entrance at Suite 500. Suite 570 was internally accessible through a fire door. Immediately after the reception and secretariat, a passage way located behind a low wall led to Suite 570 to the east. Rose Cardona was Dimitri's private Italian secretary from c.1965 until 1973, and she was later replaced by Norma Pelletier who kept the same position from 1974 to 1993. To the west and facing McGill College, the conference room was surrounded by small offices for Dimitri and his two senior associates Hans and Eva. They opened beside a drafting room for ten people at the most. Suite 570 consisted mainly of a large empty space with a working area for ten people to the south. On the eastern perimeter, a series of rooms were used respectively for drafting, storage, model making and work meeting.

[28] David Wigglesworth, answers to questionnaire. The David Boulva Dimakopoulos

project office was ultimately dissolved with the inauguration of Place du Portage Phase III in July 1978. After that date, Dimakopoulos' office address was changed to Suite 570 and for the next two decades, it was regularly expanded or contracted eastwards depending on the working area requirements for each major projects. See: Dimakopoulos & Partners, Dimakopoulos & Partners. Architecture & urban design (Montreal: Dimakopoulos & Partners, c.1979).

[29] David Wigglesworth, answers to questionnaire.

[30] Eva Vecsei and Alain Marcoux. The exact date of the mandate was July 5, 1971.

[31] Eva Vecsei, answers to questionnaire.

[32] "Regards. Projets. Hôtel Concorde Ouest," Architecture Concept (January / February 1973): 8.

[33] "Regards. Projets. Hôtel Concorde Ouest": 8.

[34] Dimitri Dimakopoulos & Associates, Concorde West Architectural (Montreal: Dimitri Dimakopoulos & Associates, 1972): 24.

[35] Dimitri Dimakopoulos: 4.

[36] Dimitri Dimakopoulos: 6.

[37] Dimitri Dimakopoulos: 22.

[38] Dimitri Dimakopoulos: 24.

[39] "25," The Canadian Architect (November 1980): 43. This special issue commemorating the 25th year of the publication included a series of yearly landmarks including the Royal Bank Plaza in Toronto by Webb Zerafa Menkes Housden for 1977. Many previous landmarks by ARCOP were also included. See also: The Canadian Architect (April 1977): 38-53.

[40] "Un édifice dont Montréal sera fière," Bâtiment (January 1973): 12. See also: "Montreal's hotel-building explosion: 4000 new rooms before '76 Olympics," Canadian Building (December 1973): 14. By the end of 1973, Concorde West was still considered in advanced planning stage and ready to start design-built construction.

[41] Hans Stenman, answers to questionnaire. In the early 1970s, Concordia had development rights on the site. The design was all prepared but tenants and financing were never realized.

- [42] Hans Stenman, answers to questionnaire.
- [43] David Wigglesworth, first interview. See also: H  l  ne Gosselin-Geoffrion, "H  tel Le Concorde, Qu  bec," Architecture Concept (November/December 1974): 15-16.
- [44] David Wigglesworth, first interview.
- [45] H  l  ne Gosselin-Geoffrion: 17.
- [46] David Wigglesworth, first interview.
- [47] H  l  ne Gosselin-Geoffrion: 16-17.
- [48] Loews Hotels, Loews Le Concorde, Place Montcalm, Qu  bec, Canada (Canada: Loews Le Concorde, 1973): convention facilities.
- [49] Hans Stenman, telephone conversation, December 11, 2000.
- [50] Hon. Andr   Ouellet and C.M. Drury, Downtown Hull (Ottawa National Capital Commission, 1978) 1-2. This announcement was made by Hon. Arthur Laing, Minister of Public Works, on April 6, 1971. Resulting from a 1969 Federal-Provincial conference agreement to make Ottawa and Hull regions part of the National Capital area, a vast redevelopment program was initiated to correct the socio-economical disparities between Quebec and Ontario. On May 20, 1969, a Federal expropriation of 15 acres of land in downtown Hull was announced by Hon. Jean Marchand, Minister of Regional Economic Expansion, simultaneously with further expropriation by the Provincial Government.
- [51] Hon. Andr   Ouellet and C.M. Drury, 4. Housing more than 12,500 Federal employees, not to mention the rest, the combined mega-complexes of Place du Portage and Place du Centre, later known as the Hull East Pole, constituted a late politico-urbanistic gesture by a Federal, Provincial, Municipal joint venture with private developers to catch up with decades of neglect and necessary regional economical recovery.
- [52] Pierre Beaupr   et al, "Hull. 1970-1980: la d  cennie prodigieuse," Architecture Qu  bec No. 17 (February 1984): 21. Urban studies for Phase I had been made previously by Daniel Lazosky for the private project of McKimm and Proulx. Later accepted by the Federal Government, his concepts were kept and reset by the NCC. They included a protected pedestrian system which was further developed and integrated into the recommendations for the East Pole. While McKimm and Proulx's original project had

been expropriated in the middle of Place du Centre site, a limited competition for Phase III was first won by Lazosky, then turned over to David Boulva Dimakopoulos, following a huge board consultation and argumentation organized by the NCC. As per Daniel Lazosky, telephone conversation, November 13, 2000.

[53] Pierre Beaupré et al: 21.

[54] David Wigglesworth, second interview in Montreal on December 18, 2000.

[55] Pierre Beaupré et al: 21.

[56] Hon. André Ouellet and C.M. Drury, 2. Initiated in 1969, the \$13-million Portage Bridge project, 1969-73, linking the downtown cores of Ottawa and Hull was simultaneously complemented by the widening project into six lanes of Maisonneuve Boulevard by the Quebec authorities.

[57] National Capital Commission, Hull (Ottawa: National Capital Commission, 1974): 4,6,8. At that time, the later phases of the complex were called Federal Buildings III and IV contrarily to Place du Portage I and II. This name originated from the discovery of 17th century artefacts on the first site excavated in 1968 by the "Place du Portage Group". Initiated by the private developers McKimm & Proulx, Place du Portage I, 1968-73, was designed by Daniel E. Lazosky. Following work interruption due to lack of government funding, the excavation site and project were expropriated by the Federal Government which rehired Lazosky, proceeding to financial cuts through the project. It was soon complemented by his adjunct Place du Portage II, 1971-76, housing 1200 civil servants in addition to the 1500 others. Daniel Lazosky, telephone conversation, November 13, 2000. See also: Pierre Beaupré et al: 14-16.

[58] Dimakopoulos Wigglesworth, DDA. Dimakopoulos Wigglesworth architectes. (Montreal: Dimakopoulos Wigglesworth, 1995): Edifice Portage No. III.

[59] National Capital Commission, Data sheets - new buildings in downtown Hull (Ottawa: National Capital Commission, 1979): 3. Place du Portage III was one of the first projects in Canada for which elaborate scientific snow studies were made. Similarly, it involved scientific wind tunnel effect tests. As per, David Wigglesworth, third interview, January 9, 2001.

[60] Daniel Lazosky, telephone conversation, November 13, 2000.

[61] Guy Desbarats, Three Views. According to Desbarats, Dimitri's very handsome office towers in Hull constituted a building complex "in the trend" of the period, but distinguishing itself by a flavour of brittle elegance. Far from the common Modern Functionalist and Miesian orthogonal slab design of the late 1960's for such office complexes, his towers were truly progressive in their volumetric breaks and formal angularities. The use of clear glass and opaque fascias horizontal strips was a Modernist device to lighten and lower the masses into a sculpturesque integrated design while the absence of Late Modern reflective glass curtain walls indicated a will to achieve his goals in a truly personal style rather than to catch up with the latest trend.

[62] National Capital Commission, Data Sheets: 3.

[63] Gregory Utas, "Evolving images. Architecture in Ottawa", Architecture Québec (April 1989): 30.

[64] Daniel Lazosky.

[65] Pierre Beaupré et al: 14-23. With the participation of Cadillac Fairview Ltd., an earlier Hull Courthouse project was evolved into Place du Centre, 1975-81, both by Lazosky. This Provincial Government and commercial complex included two office buildings, a large shopping centre and a convention centre. It was complemented by La Maison du Citoyen, 1976-80, by Lazosky and Cayer, located to the north-east. This complex would link Place du Portage I and II with Place du Portage III and IV, 1971-77 and 1974-79, by David Boulva Dimakopoulos and P.G.L. architectes with René N. Leblanc, on which design I participated, filling the gap between both areas.

[66] National Capital Commission, Hull: Place d'Accueil, 6.

[67] David Wigglesworth, third interview on January 9, 2001. At street level, Jean-Paul Mousseau (b.1927) designed a large wall murale made of vertical polychromatic strips. Coordinated by Wigglesworth, it was a successful integration of art and architecture.

[68] Dimakopoulos Wigglesworth: Place d'Accueil.

[69] Daniel Lazosky.

[70] "Citation: Place d'Accueil, Hull, Quebec," The Canadian Architect (January 1977): 38-9.

[71] David Wigglesworth, first interview. Jean-Paul Mousseau's murale accentuated the

identification of Place d'Accueil for people arriving at the level of Boulevard Maisonneuve. See: National Capital Commission, Data Sheets: 6.

[72] Consultas Inc., Rapport sur le choix d'un site en vue de l'implantation de l'Université du Québec à Montréal (Montréal: Consultas Inc., 1971): Mandat.

[73] David Wigglesworth, second interview.

[74] Consultas Inc. The name of this focal and strategic Métro station was later changed to Berri-Uqam after the completion of the project. The Quebec Government and UQAM authorities had previously decided to locate the future campus near the former site of Université de Montréal abandoned since nearly thirty years for its final relocation on the Mount-Royal in 1943. The main reasons were optimal public transportation accessibility, popular orientation and urban renewal of the former "Quartier Latin" district.

[75] Consultas Inc. Option ECBR et Conclusions.

[76] Inherited from the Papineau family, the small Place Pasteur was an opened public space located in front of the former Université de Montréal main pavilion, 1430 St-Denis Street, built in 1902 by Emile Vanier (1858-1934). In front, the Saint-Jacques Church spire, erected by Victor Bourgeau (1809-1888) in 1876-80, from the 1855 drawings of John Ostell (1813-1892), was restored and integrated to the UQAM University Phase 1 complex between 1975 and 1979 at a cost of \$0.2 million. Similarly, the Neo-Gothic sacristy stained glass woodwork designed by Bourgeau and dating from the 1859 reconstruction was preserved as a piece of architectural built-in furniture, while the southern transept designed by Perrault, Mesnard et Venne and completed in 1879 was restored and integrated to the new structure. As for the Notre-Dame de Lourdes Church, 1876-81, by Napoléon Bourassa (1827-1916), it was preserved as an independent property and integrated to the new campus site. See: René Viau, "L'UQAM, une université au coeur de la ville," Vie des Arts Vol. XXV No.99 (Summer 1980):19,21. See also: René Viau, "L'UQAM...ou le bain de jouvence du quartier Saint-Jacques," Habitat Vol. 23 No. 2 (1980): 10-17.

[77] Consultas Inc.: Considérations générales. Synthèse des objectifs et des contraintes.

[78] "UQAM. Planification," Architecture Concept (Jan.-Feb. 1973): 21-22.

[79] "UQAM. Planification: 21-22.

- [80] The name of Dorchester Boulevard was changed to René Lévesque Boulevard, following the death of the first and former separatist Quebec Premier in 1987.
- [81] “UQAM. Planification: 22.
- [82] “UQAM. Planification: 22.
- [83] “UQAM. Planification: 21-22.
- [84] David Wigglesworth, second interview.
- [85] David Wigglesworth, second interview. While Dimakopoulos & Associates were responsible for the design development, the group of planning consultants Consultas Inc. opened a project office headed by André Robillard, engineer, for the preparation of the contract documentation. Following the involvement of Denis Lamarre (b.1933) in obtaining the commission, Bernard Jodoin (1928-1991) was involved in the project office supervision. The combined team of architects was directed by Gabriel Charbonneau (b.1935), Project architect from Jodoin Lamarre Pratte, involved in the functional planification, contract documentation and site supervision.
- [86] Roland Prévost, “Une université vraiment intégrée au milieu urbain,” Bâtiment (December 1973): 28-29. This term was cited from Dimitri Dimakopoulos.
- [87] Scheduled to be completed in 1975, the first phase of construction estimated at \$37.5 million extended on two blocks on an area of 860,000 square feet. The second phase was foreseen in two stages ending in 1977, on a similar area and with a budget of \$40 million, allowing the student population to grow from 12,000 in 1972 to 24,000 in 1981. While the construction was postponed, it finally took more than two years to design the campus because of complications in integrating the new concepts into the complex. See: Esmond Choueke, “Montreal campus project designed as a mixed-use city core university,” Canadian Building (March 1977): 23.
- [88] Jim Murray et al, “The 1974 Canadian Architect Yearbook Award of Excellence,” The Canadian Architect Yearbook 74 (1974): 36.
- [89] Hélène Gosselin-Geoffrion, “Le nouveau campus de l’UQAM,” Architecture Concept (Jan.-Feb. 1975): 12.
- [90] “Première phase du campus de l’UQAM: \$37 millions,” Bâtiment (Jan. 1975): 7.
- [91] Hélène Gosselin-Geoffrion: 10-11. See also: “L’UQAM: un campus très spécial



au coeur de Montréal,” Bâtiment (March 1975): 7.

[92] David Wigglesworth, first interview.

[93] David Wigglesworth, first interview. The original inclusion into the elevations of precast concrete fascia elements was inspired from the Sussex University project, c.1965, by Sir Basil Spence. Finished up in dark brown baked clay brick only, the economy in material allowed a wall construction with various architectonic effects such as the innovative street pilaster construction retreating backwards at sharp angle with stepped back brick units. See also: “Université du Québec à Montréal,” La brique d’argile au Canada Vol. 4 No. 2 (June 1987): 1-8.

[94] David Wigglesworth, first interview. These administrative decisions resulted in ulterior public criticism relating to the lack of street animation reducing greatly the contextualist integration of the complex particularly on St-Denis Street. See: France Vanlaethem, “Le campus de l’UQAM: prix d’excellence 1980 et pourquoi pas 1990,” Architecture Québec (August 1986):23. Other public critics related to the demolition and partial preservation of the former St-Jacques Church. Nevertheless, the project won two architectural awards in Quebec and Canada. See: René Viau, “L’UQAM. Un campus greffé au centre-ville,” Le Devoir 22 Sept. 1979: 17. See also: “L’UQAM, une université au coeur de la ville,” by the same author.

For the British eyes, the UQAM campus displayed a fluid urban integration without the usual barriers indicating the trusting environment of Canadian society. See: The Architectural Review (May 1980): 279.

[95] “L’UQAM: un campus très spécial au coeur de Montréal”: 7.

[96] Esmond Choueke, 23-24.

[97] Esmond Choueke.

[98] “L’UQAM renaît,” Le Devoir 15 Sept. 1979:1. See also: “Reportage. Au chantier de l’Université du Québec à Montréal les échéanciers et les budgets sont respectés,” Bâtiment (October 1977): 18.

[99] “L’UQAM renaît,”: 1. Also present at the ceremony were Claude Pichette, rector of UQAM, Gilles Boulet, president of Université du Québec, Montreal mayor Jean Drapeau and Mgr Jean-Marie Lafontaine, auxiliary bishop of Montreal.

[100] Pierre-Richard Bisson et Raymonde Gauthier. 1890-1990. Un siècle à bâtir. 1990-2090 (Montreal: Corporation Architecture 1990: 1990): 16.

[101] Dimitri Dimakopoulos, List of Projects (Montreal: Dimakopoulos Wigglesworth, 1996). This list included a series of 36 commissions for the 1970's decade period. While some were never developed into elaborate projects, others became successive parts of larger projects. Projects of lesser architectural importance or art historical significance included: Dr. Metrakos residence, Magog, 1975; OPRON residential and office building projects, Saudi Arabia, 1977; Federal medium security prison, Drummondville, 1977; Maris residence renovation project, Montreal, 1977; St-Patrick Church renovation project, Montreal, 1977; Rideau Centre Co. Street study, Ottawa, 1977 (with Murray & Murray); Papachristidis Shipping Co. offices, Montreal, 1978; Chinese Hospital renovation project, Montreal, 1979; Canadian Hellenic Trust bank renovation (Park Ave. & Bernard), Montreal, 1979; etc. These projects indicate that the firm of Dimitri Dimakopoulos & Partners was also a commercially oriented firm concerned in acquiring a wide clientele among various Canadian communities and overseas.

[102] Winter Wondorlando (Montreal: Jacques Guillon Designers, 1973). This elegant brochure was designed for promotional purposes.

[103] "The 1974 Canadian Architect Yearbook Award of Excellence," The Canadian Architect (December 1974): 34-5. The members of the design team were Tim Grosvenor, Paul Zajfen and Aaron Lubell. Relating to this project, Dimakopoulos' firm was also involved in a regional and environmental study for the L.A.N.D. Corporation.

[104] Winter Wondorlando.

[105] "The 1974 Canadian Architect Yearbook Award of Excellence": 35.

[106] "The 1974 Canadian Architect Yearbook Award of Excellence": 34-5. One year before, Dimitri Dimakopoulos was invited to participate to The Canadian Architect Yearbook Award 1973 as a member of the jury with John C. Parkin (1922-1988) from Toronto and James A. Murray from Ottawa. Resulting from 230 entries, a total of ten awards was distributed between eight firms including Moshe Safdie, Papineau Gérin-Lajoie Le Blanc, Webb Zerafa Menkes Housden and Arthur Erickson.

[107] David Wigglesworth, second interview.

[108] Dimakopoulos & Partners. Architecture & urban design. (Montreal: Dimakopoulos & Partners, c.1979): 6. This promotional pamphlet included a photograph of the model.

[109] David Wigglesworth, second interview. This short business trip in Greece was preceded by a one-month leisure trip in 1972. Bringing his family with him, Dimakopoulos went to Europe, staying in Paris for a week before going to Greece to visit his parents. As per Irene Dimakopoulos, answers to written questionnaire on May 4, 2000.

[110] David Wigglesworth, second interview. The English name of Dimakopoulos' firm was changed from Dimitri Dimakopoulos & Associates to Dimitri Dimakopoulos & Partners in 1975. In French, it remained Dimitri Dimakopoulos & associés. After the departure of his two first senior associates, Dimakopoulos promoted Sung and Wigglesworth from the rank of unofficial junior associates to that of official partners similarly to Fernand Magnan. Following the 1974 Arabic petroleum embargo, the Gulf Petroleum Company got involved in real estate business. No active or passive solar energy systems were incorporated into this project.

[111] Dimakopoulos Wigglesworth. Développement résidentiel. Laprairie (Québec). The industrial park of 200 acres included provisions for clean industries, laboratories, head offices and storage buildings. Whenever completed, the residential project would provide for six lakes, two golf courses and over 500 acres of green spaces. Named after Canadian parks, ten different house models were designed with natural cedar siding, extra thick insulation against fuel costs, spacious well-lit interiors and dynamic exteriors with pitched roofs, patios, balconies and garages. See also: La Citière. Natural cedar homes in the Country Club City. Minutes from Montreal. (La Prairie: Gulf Development of Laprairie Inc., c.1976): 1.

[112] François Rémillard and Brian Merrett. L'Architecture de Montréal. Guide des styles et des bâtiments (Montreal: Editions du Méridien, 1990): 106. On this very important project commissioned by Lord Strathcona, William Sutherland Maxwell (1874-1952) worked as a draughtsman for his older brother William (1867-1923). Later in 1899, he went to Paris to study architecture at the Atelier Pascal before becoming Edward's associate in 1902. See also: Pierre Théberge et al, L'Architecture de Edward &

W.S. Maxwell (Montreal: Musée des Beaux-Arts de Montréal, 1991): 74-5.

[113] Pierre Théberge et al: 75. Renovated in 1979, the building interior walls were entirely re-covered with plain plaster complemented by modern fittings.

[114] Herbert C. Auerbach, St. James Street development study (Montreal: Herbert C. Auerbach Ltd., 1976): Typical floor plan.

[115] Herbert C. Auerbach: Typical floor plan and St. Jean St. elevation.

[116] Dimitri Dimakopoulos & Partners were subsequently involved in the 1978 interior design and renovation project of the former Royal Bank of Canada Building, 4192 Ste-Catherine West, Montreal, 1904, by Edward Maxwell & William S. Maxwell. Expanded in 1930 by the Royal Bank, this historical building including a 692 square meters area of rentable space was reconverted into Henrietta Anthony's antiques store by the general contractor Charles Meunier Inc. See: Répertoire d'architecture traditionnelle sur le territoire de la Communauté Urbaine de Montréal. Architecture commerciale I. Les banques. (Montreal: Communauté Urbaine de Montréal, 1980): 128-9.

[117] David Wigglesworth, second interview.

[118] Dimitri Dimakopoulos & Partners and Jacques Guillon Designers Inc. Greek Exhibition promotional brochure (Montreal: Dimitri Dimakopoulos & Partners and Jacques Guillon Designers Inc., 1976): Brief notes on the exhibition and acknowledgements.

[119] David Wigglesworth, second interview.

[120] Dimakopoulos Wigglesworth. Projet Spécial du Canal de Lachine Action 77. This 10-year redevelopment project was initiated within the context of a global strategy to revitalize the south-western sector of the Island of Montreal. It was developed by Public Works Canada with a budget of \$5 million in collaboration with many different levels of government. It was mainly an engineering and landscaping task to rejuvenate the old waterway, built in 1825-29 and abandoned since the Saint-Lawrence Seaway came into operation in 1959. See also: Dave Lord, "\$5 million to rejuvenate Lachine Canal," The Montreal Star 28 June 1977: A-2.

[121] Dave Lord A-2. Since 1974, public pressure had been mounting to clean up the canal and its banks. Bordering municipalities such as Montreal, La Salle, Ville St Pierre

and Lachine contributed \$300,000 while long term plans for a total rejuvenation of the neighbourhoods were foreseen. Making the canal impassable, the Lake St. Louis entrance was blocked with landfill since 1959 and the four locks at Lachine, Côte St-Paul, Des Seigneurs and Du Port locations were permanently blocked. Allowing boating on three closed basins, the first phase of renovations took place mainly near Des Seigneurs bridge. After work completion, the canal land was turned over to Parks Canada to be opened in mid-1978. See also: Public Works Canada, Canal de Lachine. Report on the development concept (Montreal: Public Works Canada, 1977): 19-21.

[122] David Wigglesworth, second interview. While the coordination was mostly done by Wigglesworth, the urban design was developed by Patrick Glorieux and the site supervision by Pierre Brisset (b.1947). It was nevertheless an important urban project for Montreal allowing the rediscovery of the old Lachine Canal by means of an historical and recreational park that soon became very popular. Offering great city impact, this project was a good piece of urban design for Montreal.

[123] S. Blanchet, “Le Palais des congrès: enfin une réalité,” Bâtiment (March/April 1983): 21. Following discussions since 1977, this architectural competition was the first of its kind sponsored by the Quebec Government under the first Parti Québécois administration (Nov. 1976 to Dec. 1985).

[124] David Wigglesworth, second interview. At a period when there was still work on the UQAM University project, Dimakopoulos was involved with the rest of his staff on a very intensive charette. Wigglesworth was the only one uninvolved. Struggling with the program requirements, he had to resolve a very difficult puzzle, the building envelope being almost impossible to fit within the site without cantilevering above Vitre Street.

[125] “Un Palais des congrès sortant de l’ordinaire conçu par une équipe du Québec,” Bâtiment (Oct. 1978): 16-19. The four other projects displayed a similar basic rectangular volumetry with varying secondary geometries. All project included an elaborate set of aerial terraces to the east. The winning scheme featured a circular ramp to the south and a cantilevering angular curtain-wall to the east.

[126] S. Blanchet 21. Featuring the signature designs of Jean-Louis Lalonde, Dimitri Dimakopoulos, Jean Ouellet, Denis Lamarre and André Blouin, five consortiums of

architects & engineers were selected as finalists, receiving the sum of \$50,000 to cover their expenses. The architectural consortiums were: Prus + Labelle Marchand Geoffroy Lemoyne + Hébert Lalonde; Dimakopoulos Magnan + Gillon Larouche; La Haye Ouellet + Longpré Marchand Goudreau; Jodoin Lamarre Pratte + Arcop Associés + Marcoux Durand Lemieux; Blouin & Blouin + Gauthier Guité Roy. See also: “Un Palais des congrès...” 19-21.

[127] David Wigglesworth, first and second interviews. The contestation was in vain and the design of the winning project signed by Jean Ouellet was carried over by Victor Prus (b.1917) through all its subsequent phases and without major modifications. The start of construction works took place on October 19, 1979, and by May 27, 1983, Premier René Lévesque (1922-87) was opening the \$87-million Palais des Congrès. See: “Début des travaux au Palais des congrès,” Le Devoir 19 Oct. 1979: 3. See also: Paul Delean, “Levesque to open \$87-million Palais,” The Gazette 27 May 1983: 1.

[128] David Wigglesworth, second interview. Between the results of this competition and those for the new Palais de Justice de Québec in August 1979, Dimakopoulos’ firm went through a period of uncertainty and a possible closure of the office was foreseen due to lack of work. While its only project was the \$1-million renovation of the Chinese Hospital of Montreal, 1979, there were only the partners and a secretary in the office.

[129] “Palais de Justice à Québec” Le Devoir 22 February 1979: 8. This followed the decision taken by the Quebec Ministerial Cabinet to relocate the old and obsolete Palais de Justice de Québec, built in 1887-88 by Eugène-Etienne Taché (1836-90) and Pierre Gauvreau (1813-84), in a new complex located on a 25,000 square meter site delimited by the Saint-Charles River, the Dufferin-Montmorency Highway and Ramsey Street. Requiring no expropriation, this site, easily accessible through the adjacent highway and three nearby boulevards, was located near the Gare du Palais in the Saint-Roch district. The \$41.4 million (1979) project allowed urban renewal and socio-economical recovery in an area requiring revitalization. It also permitted the adequate implantation of new technologies in upgraded facilities, improving services for a larger community. See also: Le prochain Palais de Justice de Québec (Quebec: Gouvernement du Québec. Ministère des Travaux publics et de l’Approvisionnement, 1979): 6-7.

[130] Le prochain Palais de Justice de Québec: 2-5, 8. Following the public announcement inviting architectural firms to regroup in consortium to submit their proposals, a selection committee proceeded to a pre-selection of 5 teams from the 16 original participants. The five finalists were: Dimakopoulos Magnan & associés + Chabot, Gilbert, Jarnuskiewicz, Mainguy + Larose, Laliberté, Petrucci; Achard & Boivin + Bégin & Rodrigue + Lemay & Leclerc; De Montigny, Dion, Métivier, Gagnon + David, Boulva, Cleve + Blouin, Blouin & associés; Gauthier, Guité, Roy + St-Gelais, Tremblay, Bélanger; Jodoin, Lamarre, Pratte & associés + Arcop & Associés + Doran & Dubé.

[131] David Wigglesworth, third interview.

[132] David Wigglesworth, third interview. Fernand Magnan and Gilles Chabot also participated to the planning process. While Dimakopoulos was mainly concerned with the exterior design, selection of materials and interior decoration, Sung was responsible for the general concept. For the contract documents, Gilles Larose appointed Gilles Parizeau as Project architect who became assisted by Victor Laliberté (b.1922). As per: Gilles L. Larose, telephone conversation, January 16, 2001.

[133] David Wigglesworth, third interview. The standard design process consisted in establishing design criterias from the synthesis of previously determined objectives and constraints.

[134] David Wigglesworth, third interview. Soft embankments formed by the remnants of the Old Harbour wharfs and sedimentary deposits from the Saint-Charles River were found in the sub-soil which was excavated on six meters and filled with stronger compacted banks. See: "Place de la Justice" Bâtiment (Nov./Dec. 1983): 21-22. In addition to the main building, a three-storey exterior parking structure for 750 cars was built under the Dufferin-Montmorency Highway to accomodate the users of the complex. Surrounded by many historical buildings including the Gare du Palais, the site also allowed the future development of a mega-project to revitalize the Saint-Roch/Saint-Sauveur district. See: Place de la Justice de Québec (Quebec:Gouvernement du Québec. Ministère de la Justice, 1983): 7.

[135] DDA. Dimakopoulos Wigglesworth Architects: Palais de Justice de Québec.

[136] David Wigglesworth, third interview. Progressive sketches were developed,

showing embryonic volumetries and rough circulation diagrams. Synthetizing program and conceptual informations, the team analyzed and developed each option in accordance with the various criterias.

[137] David Wigglesworth, third interview.

[138] David Wigglesworth, third interview. Other working models would follow until the final presentation model made by a professional model-maker.

[139] DDA. Dimakopoulos Wigglesworth architectes: Palais de Justice de Québec.

[140] “Place de la Justice” Bâtiment (Nov./Dec.1983): 21. A monumental sculpture by Louis Archambault (b.1915) made of a trellis of painted aluminum extrusions would later ornate the atrium. See: Palais de Justice de Québec: fiche technique (Quebec: Société Immobilière du Québec, 1993): 1. An original design concept developed by Jean-Paul Mousseau and the architects allowed vegetation to grow on a sculptural grid lattice work in order to soften and humanize the severity of the atrium space in which geometric patterns were dominating. Later commissioned for the artwork, Archambault rejected this design concept, and the end result was much more stark and mechanical than originally thought. As per David Wigglesworth, third interview.

[141] Facing the southern entrance, a large metal signaletic sculpture by René Taillefer (b.1939) was added. It displayed a strong visual impact on all surrounding circulations. See: Palais de Justice de Québec: fiche technique: 2.

[142] A mobile metal fountain-sculpture by Armand Vaillancourt (b.1929) was added. Representing the Arm of Justice, it was animated by light and water effects. See: Palais de Justice de Québec: Fiche technique: 2. Further north and facing the Saint-Charles River, a wide expanse of green spaces allowed pedestrian circulation.

[143] “Place de la Justice” 21. Copper was selected as exterior material in order to match the roofs of old architectural landmarks nearby. In order to accelerate the greening process of the copper, laboratory researches were undertaken with the collaboration of the C.R.I.Q. (Centre de recherches industrielles du Québec). Difficult to match evenly, the resulting artificial patina was not fully satisfactory. Similar studies were undertaken to improve the resistance and life span of the slate veneer.

[144] The six-storey structure was also designed to be energy efficient by means of



minimal exposed surfaces. It could be converted to solar power to cut fuel or electrical consumption by 30 %. See; Harvey Enchin, “Contract gives architect hope,” The Gazette (c.29 August 1979).

[145] David Wigglesworth, third interview. Bringing in the office four or five laid-off people for the production of the final presentation drawings , Dimakopoulos agreed with them that they would only get paid if their team was winning, but at a double time rate. As a result, the final cost of the competition exceeded largely the \$60,000 award. Living literally in the office, the enlarged team completed the work with a two-day charette. At the end, the walls of the office were covered with sketches and drawings.

[146] As found in the original drawings competition document intitled Palais de Justice of Quebec, Quebec City,by the winning team.

[147] David Wigglesworth, third interview.

[148] Le prochain Palais de Justice de Québec: 7.

[149] Le prochain Palais de Justice de Québec: 8.

[150] “Place de la Justice” 20.

[151] Harvey Enchin.

[152] Harvey Enchin. See also: “L’échéancier est respecté pour le Palais des congrès de Montréal et le Palais de Justice de Québec,” Bâtiment (March 1980): 19. The production team for the contractual documents included staff from both Montreal firms. The construction supervision was carried over by the Quebec firm.

[153] La Place de la Justice. Un projet réalisé à l’intérieur des coûts et des échéanciers prévus (Quebec: Gouvernement du Québec. Ministère des Travaux publics et de l’Approvisionnement, October 27, 1983): 1-3. See also: “La Place de la Justice. Autres contrats accordés”. In addition to the site preparation, they included the parking structure, the concrete infrastructure, the general contract, the electrical and mechanical contract, the interior finishes and accessories, and the exterior works. The construction process was supervised by André Sauvageau, Project Manager for the Department of Public Works. In addition to the \$54.4-million construction cost, \$6-million was spent for consultants fees and \$1.3-million for the land purchase.

[154] “La Place de la Justice. Autres contrats accordés”, Journal Constructo (1st Nov.

1983): 20.

[155] "Place de la Justice" 20-21.

[156] Louise Lemieux, "Palais de Justice: dans cinq jours le déménagement," Le Soleil 24 September 1983: C-9.

[157] "La Place de la Justice. Une réalisation tout à l'honneur des travailleurs québécois," (Quebec: Gouvernement du Québec. Ministère des Travaux publics et de l'Approvisionnement, 28 October 1983): 1-2. Elected deputy of the first Parti Québécois Government on November 15, 1976, my homonym Alain Marcoux (b.1945) acted as Minister of Public Works and Supplies during its second mandate from April 30, 1981 until December 12, 1985. During this mandate, he participated to the launching of the architectural competition for the new Musée d'art contemporain de Montréal on November 19, 1983. He also inaugurated the Palais des congrès de Montréal with René Lévesque on May 27, 1983, followed by the Palais de Justice de Québec on October 28, 1983.

[158] Dimakopoulos & Partners. List of projects. Another project was the \$30,000 exterior site planning for the Guttman Residence, Montreal, 1980.

[159] Hellenic Community of Montreal 3. Covering a total area of 76,000 square feet, the 1982 complex included the Primary School Socrates - Campus II with 27 classrooms, gymnasium, cafeteria, "Grande Salle", as well as the Hellenic Library and Community's Head Office. Moving to the 5777 Wilderton expansion in 1988, the latter was converted into a daycare center for 46 children. The site also included an exterior parking for 106 cars.

[160] It also featured a curtain wall section facing the back of the cathedral.

[161] David Wigglesworth, second interview. Following the Hudson's Bay Headquarters project, Winnipeg, late 1960s, by ARCOP, Dimakopoulos & Partners were hired by John McKintyre, vice-president of the Hudson's Bay Company. Another project for the Simpson's Company of Toronto followed with the \$16-million Simpson's Store, Halifax, 1980-82, complemented by an interior parking for 750 cars. Located in the Armdale Mall on Chebucto Road, this second key project involved a steep hill site allowing the design of a multi-level mall.

- [162] The Rideau Centre, Ottawa, 1977-83, by Crang & Boake, was conceived as the main attraction center of downtown Ottawa. This major commercial complex was at the time the largest construction project in the capital.
- [163] The Rideau Mall was a pedestrian mall covering the sidewalks of Rideau Street along the Rideau Centre. Used as refuge by homeless people, it soon met the store administration opposition and was subsequently destroyed and put back into a street.
- [164] David Wigglesworth, third interview. Magda Kuskowski (b.1952) also assisted in the design.
- [165] David Wigglesworth, third interview.
- [166] David Wigglesworth, third interview. Dimakopoulos & Partners were recommended to Wong & Tung by Eddy Shan, a Chinese Australian architect formerly with David Boulva Dimakopoulos, working on the same project. Following the design of an enormous complex on Site "A" for Swire Corporation, a British development firm from London, England, Wong & Tung had difficulties meeting their client requirements.
- [167] David Wigglesworth, third interview. This commercial centre included two office towers of 1.2 million square feet floor area, and a commerce and retail centre of 1.1 million square feet floor area. It also included a parking for 4000 cars.
- [168] David Wigglesworth, third interview. Contemporary with the Palais de Justice de Québec, the project proposed a large main atrium with similar details. It included a skating rink and was surrounded by seven storeys of retail.
- [169] DWA. Dimakopoulos Wigglesworth architectes: La Tour Boumediene.
- [170] David Wigglesworth, third interview. Similarly, Au Chemin des Crêtes, Algiers, 1982, was an urban design development study done by Dimakopoulos for Lavalin.
- [171] DWA. Dimakopoulos Wigglesworth architectes: La Tour Boumediene.
- [172] DWA. Dimakopoulos Wigglesworth architectes: La Tour Boumediene. See also: Tour restaurant. Parc zoologique et des loisirs d'Alger: Competition drawings.
- [173] David Wigglesworth, third interview.
- [174] DWA. Dimakopoulos Wigglesworth architectes : La Tour Boumediene.
- [175] Gilles L. Larose, telephone conversation on January 16, 2001.
- [176] "La Laurentienne: Un investissement de \$75 millions de dollars," Bâtiment

(March/April 1984): 9. See also: "Tours à bureaux: Les impératifs de la mode," Bâtiment (March/April 1989): 24.

[177] "La Laurentienne" 9.

[178] David Wigglesworth, third interview.

[179] David Wigglesworth, third interview. See also: DWA. Dimakopoulos Wigglesworth architectes: Edifice La Laurentienne. Prior to this project, a proposal with a square tower had been submitted by an undistinguished architect. He was asked by the same client to liberate the corner at 45 degree. This idea was taken over by Dimakopoulos and Sung. As per: Gilles Larose, telephone conversation, January 16, 2001.

[180] David Wigglesworth, third interview. See also: "Bank of Canada Head Office, Ottawa," The Canadian Architect (June 1978): 22-5 Located on the Sparks Mall and integrating the 1936 original Art Deco granite Bank of Canada Building, this new structure featured a quasi-rectangular plan with glazed enclosure featuring vertical V-shape recesses and angular corners. The curtain-walls consisted in mirror glass vertical panels complemented by copper mullions, spandrels, parapet fascias and column siding.

[181] M. Castro, "L'Edifice La Laurentienne," Bâtiment (May/June 1985):13. While the quality of the pre-oxydized copper panels submitted by the sub-contractor was not satisfactory, Dimakopoulos & Partners had to accept its sub-standard quality. This technical failure of the pre-oxydized copper brought Dimakopoulos' subsequent use of regular copper on Le 1000 de La Gauchetière tower. The surrounding landmarks were mainly the Marie-Reine-du-Monde Cathedral, 1870-94, by Victor Bourgeau and Père Michaud, designed in the Neo-Renaissance style, and the third Sunlife Building, 1913-33, by Darling and Pearson, designed in the Beaux-Arts style. See: François Rémillard and Brian Merrett: 60, 110.

[182] M. Castro 13.

[183] "La Laurentienne" 9.

[184] The Dominion Square area was subsequently developed with Le 1000 de La Gauchetière tower, 1988-92, by Dimakopoulos & associés and Lemay & associés, the 1250 René Lévesque / IBM-Marathon Tower, 1988-92, by Kohn Pedersen Fox and Larose Petrucci & associés, and the Molson Center, 1992-95, by Le Moyne Lapointe Magne and

Lemay & associés.

[185] “L’Edifice La Laurentienne” 13.

[186] “L’Edifice La Laurentienne” 13. An outdoor bronze sculpture called Le Cactus Modulaire, 1977, by Robert Roussil (b.1925) was also installed on the site, at the back of the building, facing Peel Street.

[187] David Wigglesworth, third interview.

[188] David Wigglesworth, third interview.

[189] “L’Edifice La Laurentienne”12-13.

[190] David Wigglesworth, third interview.

[191] “L’Edifice La Laurentienne” 13.

[192] Début des travaux de l’ Edifice La Laurentienne à Montréal. (Montreal: La Laurentienne Press Official Statement, 15 February 1984).

[193] “L’Edifice La Laurentienne” 12.

[194] La Laurentienne press official statement, 15 February 1984.

[195] “L’Edifice La Laurentienne” 12.

[196] This was due to the fact that the firm had already won the Palais de Justice de Québec competition.

[197] “Le concours du musée de la Civilisation,” Achitecture Québec (October 1981): 27. The other architects were Jean-Luc Poulin, Paul Faucher, Jacques Le Barbanchon, Louis A. Hamel, Jean-Pierre Lapointe and Jean-Louis Beaulieu.

[198] The winning consortium called Team A was led by Claude Belzile. It included the following firms: Belzile, Brassard, Gallienne, Lavoie & Sungur Incesulu with Moshe Safdie and Desnoyers Mercure. Team B led by Guy Gérin-Lajoie included PGL architectes, DeMontigny Métivier Gagnon and Pierre Morel. Team C led by Denis Lamarre included: Jodoin Lamarre Pratte, Arcop & Associates and Dorn & Dubé. Team D led by Gilles Marchand included Boutin Ramoisy, Longpré Marchand and La Haye Ouellet Reeves. Team E led by Jean-Marie Roy included Gauthier Guité Roy and Saint-Gelais Tremblay Bélanger Campeau. The winning project was carried over by Team A with Moshe Safdie as Principal in charge of design. It was completed in 1989.

[199] David Wigglesworth, third interview. A previous feasibility study for the Dawson

College Selby Campus, located downhill from Atwater Avenue below Saint-Antoine Street, was undertaken in 1977 by Dimitri Dimakopoulos & Partners. It was an urban design study for the establishment of the only owned Dawson downtown campus, the rest being rented. For the Phase I, II and III of the Dawson College project, Gabriel Charbonneau acted as Project Architect for Jodoin Lamarre Pratte & associés, involved in functional planning, contract documentation and site supervision.

[200] David Wigglesworth, third interview. This feasibility study dealt with thirteen campuses academic groups which did not want to reunite into one large campus. While each of them was previously quasi-independent, it became necessary to centralize their various administrations.

[201] DWA. Dimakopoulos Wigglesworth architectes: College Dawson. Campus Atwater. Designed according to the French Beaux-Arts School tradition by one of its former students, this exceptionally large structure featured a clear symmetrical plan with a multiplicity of semi-enclosed courts and wings, a balanced hierarchy of masses culminating with the domed chapel, a spaciousness and luminosity of interior spaces, a high refinement in the woodworks and artworks, and a careful execution of details. Located on Sherbrooke Street, the main entrance, centrally located on axis between four short protruding wings and laid out in a French Neo-Renaissance manner, presented the monumental recessed façade of a chapel designed in a Romano-Byzantine version of the French Neo-Romanesque style. It featured a giant arch porticoe and a high copper dome complemented by four smaller decorative corner cupolas. Perched at the highest point, a replica statue of the Notre-Dame de la Garde Sanctuary, Marseilles, 1864, designed in the Neo Romano-Byzantine style by J. H. Espérandieu (1829-74), rose 125 feet above street level. Costing \$638,780, the enduring building was erected by the contractors Martineau and Prénouveau. See: Pierre-Richard Bisson, “Un monument de classe internationale. La Maison-Mère de la Congrégation Notre-Dame,” Architecture Québec ARQ No. 31 (June 1986): 14-18. See also: Karen Kelso, Dawson College Building, Essay (18 April 2000).

[202] Pierre-Richard Bisson: 18. See also: François Rémillard and Brian Merrett: 87.

[203] David Wigglesworth, third interview.

[204] David Wigglesworth, third interview. See also: Explorer Montréal 2nd ed.

(Montreal: Editions Libre Expression, 1990): 313-4. CEGEP was the current Quebec abbreviation for “Collège d’enseignement général et professionnel”.

[205] David Wigglesworth, third interview.

[206] David Wigglesworth, third interview.

[207] David Wigglesworth, Presentation to the Westmount Historical Society at the Atwater Campus for Dawson College, situated in the former Motherhouse of the Congregation Notre-Dame. Montreal (22 September 1994): 1-6. About 90 to 95% of the interiors of the Nunnery had to be demolished. Non-enclosed luminous staircases, creaking maple floors, obsolete partitions and old wood trims, brittle oak mouldings and panellings had to be demolished. Similarly, most of the original reinforced concrete structure was replaced by a new one on which new light weight gyproc partitions were built. Here and there, parts of the original structure remained. Completed in 1908, it was the second reinforced concrete structure to be built in North America. Containing smooth iron bars, it was made of concrete members with wood-like dimensions. Echoes of the past, graceful arched windows encased in original wood mouldings, original carved oak doors and carved pilasters in the long halls were also preserved. See also: Karen Kelso.

[208] David Wigglesworth, Presentation to the Westmount Historical Society. Except for the intricately latticed iron chandeliers hanging from the vaulted ceiling, the Casavant organ pipes anchored on the north wall, the brass railings and many other decorative elements, all religious artifacts were removed, including two ornately carved confessionals, the original liturgical paintings and the sepulture of the congregation founder Saint Marguerite Bourgeois (1620-1700). See also: Karen Kelso.

[209] David Wigglesworth, Presentation to the Westmount Historical Society. The new library function was selected out of five options. Converted into a reading room reminiscent of the 19th century great libraries, it became the heart of the new institution and symbolical of its past function. A series of doors enclosed in burnished wood wall panelling highlighting the lateral walls was added, providing discrete fire exits. The altar and pulpit on the south wall were reutilized as the librarian’s circulation desk and 600 study stations were installed throughout the Reading Room which took advantage of lateral natural lighting. See also: Karen Kelso.

[210] David Wigglesworth, Presentation to the Westmount Historical Society. New metallic double glazed windows were installed within the original window openings, conforming to the original configuration, profile and colour.

[211] DDA. Dimakopoulos Wigglesworth architectes: College Dawson. Phase I & II. For the design of the Library and the Cafeteria, Wigglesworth was assisted by Andrea Wolff (b.1952) and Magdalena Kuskowsky.

[212] David Wigglesworth, third interview.

[213] Karen Seidman, "Dawson College starting the year with new building, new boss", The Gazette (21 June 1988): A-7.

[214] Jean Sutherland Boggs, "Twelve proposals for the National Gallery of Canada and for the National Museum of Man. Introduction," Section A Supplement (August 1984): 3. Following the creation of the Canada Museums Construction Corporation in February 1982, recommendations for two building sites were made to the cabinet of Pierre Elliott Trudeau in October 1982. The Corporation mandate was to manage the construction of the National Gallery of Canada in Ottawa and the National Museum of Man in Hull with a budget of \$186.5 million and a time span of five years.

The latter requiring 50% more space than the National Gallery dictated its future location in an area purchased in Hull from E. B. Eddy Forest Products Ltd. Lying at the Ottawa River's edge and facing Parliament Hill, this area was renamed Parc Laurier. See: "Site set for gallery and museum," The Globe and Mail (2 October 1982): E-7.

Since time and money were limited and given the fact that two architectural competitions for the National Gallery had already been held in 1952 and 1976-77, the latter won by John C. Parkin Architects and Planners of Toronto but remaining unbuilt, it was decided that twelve architectural firms selected out of seventy-eight would be privately invited to submit a proposal for a \$20,000 fee. See: "National Gallery, Museum invite architect's proposals," The Gazette (8 January 1983): F-8, and as per David Wigglesworth, third interview.

A letter from Jean Sutherland Boggs, chief executive director and former National Gallery director, was sent on December 10, 1982 to the twelve participants, requesting a three-week proposal to be submitted before January 17, 1983. See also: "Sites set for



gallery and museum” E-7, and Jean Sutherland Boggs 3.

[215] Jean Sutherland Boggs 3.

[216] David Wigglesworth, third interview. See also: “Twelve proposals for the National Gallery of Canada and the National Museum of Man. Dimakopoulos and Partners and Gordon Edwards Architects,” Section A Supplement (August 1984): 32. Employed by Dimakopoulos, the other participants were Andrea Wolff, Magdalena Kuskowski and Adriana Pancou.

[217] David Wigglesworth, third interview. In the summer of 1983, Dimakopoulos went back to Europe for a month. This leisure trip with his wife and older daughter Irene included two weeks in Italy to visit Florence, Sienna, San Gimignano and Ravenna, and two weeks in Greece to visit his mother in Athens.

[218] Twelve Proposals 32.

[219] Twelve Proposals 32.

[220] Twelve Proposals 32

[221] Twelve Proposals 33-34. From the main entrance, at ground level, the library and administration were accessible one level below. The main auditorium, classrooms, library, cafeteria and children’s museum were also located at the lower level below the thematic and study exhibits areas.

[222] David Wigglesworth, third interview. Although submitting only one proposal, each firm could still be considered for the other museum and the final selection decision was not that of the Corporation since it could only make a recommendation to the Cabinet. As per: Joan Sutherland Boggs 3.

Considered at the time by the media as a strictly private affair, the details and participants of this architectural contest were kept completely secret. See: “Sites set for gallery and museum” E-7, and “Architectural contest for museum, gallery strictly private affair,” The Globe and Mail (5 January 1983) 1.

While Moshe Safdie and Desnoyers Mercure were evolving their proposal for the National Museum of Man, Pierre Elliott Trudeau contacted Moshe Safdie by telephone one week before the end of the competition, asking him to prepare a quick design for the National Gallery.

As per: David Wigglesworth, third interview.

[223] Joan Sutherland Boggs 3.

[224] Joan Sutherland Boggs 3. Nine months later, on November 28, 1983, the architectural plans and models of the two \$186-million project were publicly unveiled by Francis Fox, Minister of Communications, in a Parliament reception room. While both designs were reflecting Canadian pride and creativity, the National Museum of Man, designed by Douglas Cardinal (b.1934) displayed a Modern Organic architecture, featuring two monumental stepped geological curving masses dominated by large beehive domes. Immediately after the unveiling ceremony, the ground was broken for the two buildings by detonating simultaneous explosions from a viewpoint at the back of the Parliament Central Block. See: "\$186-Million projects unveiled," The Globe and Mail 29 November 1983: 17, "Bill for museums will be \$186 Million," The Gazette 29 November 1983: B-1, and "Museum plans unveiled," The Gazette 29 November 1983: B-6.

[225] "Canadian Museum of Civilization, Hull, Quebec," The Canadian Architect (November 1989): 18-19. See also: "The National Gallery of Canada, Ottawa," The Canadian Architect (June 1988): 29.

[226] David Wigglesworth, third interview.

[227] David Wigglesworth, third interview.

[228] David Wigglesworth, third interview. British Protectorate in 1914, Bahreïn became independent in 1971. In 1986, it was linked by a bridge to the Saudi Arabian coast, connecting to a highway leading to Riyadh, Saudi Arabian Capital located at less than 400 kilometers east.

[229] David Wigglesworth, third interview.

[230] David Wigglesworth, third interview.

[231] David Wigglesworth, third interview.

[232] David Wigglesworth, third interview. For the design development of Houses #3 and #4, Dimakopoulos was assisted by Andrea Wolff and Magdalena Kuskowsky. The architects were never allowed to take photographs of any of these houses whenever completed.

[233] DDA Dimakopoulos Wigglesworth architectes: No.2 Place Alexis Nihon. The

Master of works was the Alexis Nihon Corporation. The existing complex called Place Alexis Nihon included a basilar podium infrastructure, a northern higher residential tower and a southern lower office tower. It was originally designed by Harold Ship Architect (b.1922), c.1965-66. The new tower was part of a \$30-million global project including the interior renovation of the shopping mall by Ian Martin architect. The extended mandate also included the renovation of the existing office tower and complementary external building envelope of the whole complex by Dimitri Dimakopoulos & Partners and Larose Laliberté Petrucci.

[234] DDA. Dimakopoulos Wigglesworth architectes: No.2 Place Alexis Nihon.

[235] “Complexe A. Nihon: La structure de la nouvelle tour à bureaux a été complétée,” Bâtiment (July-August 1985): 10.

[236] DDA. Dimakopoulos Wigglesworth architectes: No.2. Place Alexis Nihon. Requiring reinforcing of the existing structure and foundations at the lower levels of the complex, a steel structure was selected, reducing weight to a minimum, while strict coordination procedures were taken to avoid conflict between construction and commercial operations. In addition to physical constraints, the building located both in Westmount and Montreal required extra zoning bylaws coordination.

[237] David Wigglesworth, third interview. It was developed from a difficult massing because the new floor plan was pre-determined by the existing structure originally designed with provisions for a future apartment tower with columns built accordingly.

[238] David Wigglesworth, third interview.

[239] David Wigglesworth, third interview.

[240] Bâtiment (Nov./Dec. 1984): 7 and (Jan./Feb.): 8.

[241] “Il aura fallu une intervention humaine pour déclencher l’alarme à la Place Alexis Nihon,” La Presse 17 March 1987: A-3. Exceeding \$100 million in damage, this conflagration was one of the most important in Canadian history. See also: “Le feu de la Place Alexis-Nihon devrait servir de leçon, disent les assureurs,” La Presse 15 March 1987: B-1.

[242] DDA. Dimakopoulos Wigglesworth architectes: No1. Place Alexis Nihon.

[243] David Wigglesworth, third interview.

- [244] Magda Kuskowski, telephone conversation, January 23, 2001.
- [245] David Wigglesworth, third interview.
- [246] One Place Alexis Nihon (Montreal: The Alexis Nihon Group, 1987):1
- [247] David Wigglesworth, fourth interview in Montreal on January 31, 2001.
- [248] David Wigglesworth, fourth interview, and Raymond Lamy, Construction Manager for DPW, telephone conversation on December 4, 2000.
- [249] Architectes en Consortium David Boulva Cleve, Dimakopoulos & associés, Gordon Edwards. Centre de recherche en biotechnologie, Montréal. Document de proposition préparé pour Travaux Publics Canada. (Montreal: Architectes en consortium David Boulva Cleve, Dimakopoulos & associés, Gordon Edwards, June 28, 1983).
- [250] David Wigglesworth, fourth interview.
- [251] Architectes en consortium David Boulva Cleve, Dimakopoulos & associés, Gordon Edwards. Centre de Recherche en Biotechnologie, Montréal. Présentation du concept préliminaire pour Travaux Publics Canada. (Montreal: Architectes en consortium David Boulva Cleve, Dimakopoulos & associés, Gordon Edwards, September 1983).
- [252] Architectes en consortium David Boulva Cleve, Dimakopoulos & associés, Gordon Edwards. Institut de recherche en biotechnologie, Montréal. Présentation du concept pour Travaux Publics Canada. (Montreal: Architectes en consortium David Boulva Cleve, Dimakopoulos & associés, Gordon Edwards, October 3, 1983).
- [253] David Wigglesworth, fourth interview. While Dimakopoulos was not too involved in the later stages, Andrea Wolff, assisted by Magda Kuskowsky, developed the preliminary design, acting as chief designer on the project while the remaining firms of the consortium were involved in the contract documentation and site supervision.
- [254] Architectes en consortium. Centre de recherche en biotechnologie, Montréal. Présentation du concept préliminaire pour Travaux Publics Canada: Site.
- [255] David Wigglesworth, fourth interview.
- [256] Architectes en consortium. Institut de recherche en biotechnologie, Montréal: Plan du site.
- [257] Guy Desbarats Three Views. For him, the quality of Dimakopoulos' building

was very apparent from a design skill and detail care point of view.

[258] DWA. Dimakopoulos Wigglesworth architectes: Institut de recherche en biotechnologie.

[259] “Institut de recherche en biotechnologie: Fin des travaux prévue pour Mars.” Bâtiment March-April 1985: 7.

[260] “Institut de recherche en biotechnologie.” 7.

[261] David Wigglesworth, fourth interview. The base building cost was \$28 million. It was furnished with \$30 million of equipment and required \$25 million to operate in 1987. See: Jan Ravensbergen, “4 firms find a home at Biotechnology Institute,” The Gazette 3 Dec. 1987: E-2.

[262] Jan Ravensbergen, “Quebec seeking partners for its Laval pharmaceuticals company,” The Gazette 4 Dec. 1984: B-5. Wholly owned by the SGF, a Provincial Government holding company, Bio-Mega was created around a core group of 60 scientific and research personnel who became available when the American company Ayerst Laboratories Inc. cut back its Montreal research facilities in 1983.

[263] Richard Dupaul, “Bio-Méga Inc.: des retombées avantageuses attendues de la bio-technologie.” Finance Vol. 6 No. 43 19 August 1985: 25. Splitted in two, Bio-Mega Inc. developed research services in pharmacology with a vocational orientation in diagnostics while Bio-Mega Diagnostic Inc. was concerned with the production of measurement bundle kits, products and reactives. See also: “Bio-Mega Centre aid appeal renewed.” The Gazette 13 Nov. 1983: D-1.

[264] Dominique Lamarche, “Bio-Méga. Au-delà des dunes, quelque part où n’importe où veut dire ailleurs qu’ici...” Décormag No.161 March 1987: 94.

[265] David Wigglesworth, fourth interview. See also: DWA. Dimakopoulos Wigglesworth architectes: Les laboratoires Bio-Mega.

[266] David Wigglesworth, fourth interview. For the design, Andrea Wolff was assisted by Magdalena Kuskowski and Elizabeth Shapiro (b.1954).

[267] David Wigglesworth, fourth interview. See also: Dominique Lamarche: 90.

[268] David Wigglesworth, fourth interview. See also: Dominique Lamarche: 92.

[269] David Wigglesworth, fourth interview. See also: Dominique Lamarche: 90,92.

- [270] David Wigglesworth, fourth interview. The flamboyant director Jacques Gauthier had requested an innovative architectural design and color scheme.
- [271] David Wigglesworth, fourth interview.
- [272] Dominique Lamarche 92-3.
- [273] DDA. Dimakopoulos Wigglesworth architectes: Les laboratoires Bio-Mega.
- [274] DDA. Dimakopoulos Wigglesworth architectes: Les laboratoires Bio-Mega.
- [275] David Wigglesworth, fourth interview. See also: Dominique Lamarche 90. The “Spectra-Glazed” concrete blocks with ceramic finish featured a decorative vertical joint in the center, generating a square tiling pattern effect.
- [276] Designed in 1984, this Post-Modern building shared many formal similarities with the Fujimi Country Club, 1972-75, by the Japanese Arata Isozaki (b.1931), one of the greatest World Post-Modernists. See: Charles Jencks, Guest Ed., Post-Modern Classicism. The New Synthesis (London: Architectural Design, 1980) 83-5. The 10-year gap between the two indicates that Dimakopoulos, more at ease with the Late-Modernist vocabulary, was a late comer to Post-Modernism, similarly to Arthur Erickson and Moshe Safdie, many years after Peter Rose (b.1943) in 1976 and Philip Johnson in 1978.
- [277] Charles Jencks, The Language of Post-Modernism 6th rev. & enl. ed. (London: Academy Editions, 1991).
- [278] Dominique Lamarche 94. See also: “Bio-Mega Centre aid appeal renewed.”
- [279] Vallier Lapierre, “Bio-Méga compte synthétiser de nouveaux médicaments d’ici deux à trois ans.” Les Affaires Vol. 63 No.6 9 Feb. 1991: C-18. See also: “Bio-Mega Centre aid appeal renewed.”
- [280] Richard Dupaul. See also: Dominique Lamarche 93. Between 1990 and 93, Dimakopoulos’ firm proceeded to a series of successive interventions including an aids research laboratory in 1990, a new mechanical building in 1991, an addition of offices, instrument and conference rooms in 1992 and an enlargement of the laboratories in 1993 for a total cost of \$1.4 million. A major \$7.2-million south wing expansion project for Bio-Mega / Boehringer Ingelheim Research Inc. was also implemented by David Wigglesworth under the name of Dimakopoulos Wigglesworth architectes in 1995-97, following the sale of Bio-Mega by the SGF for \$23.4 million to Boehringer Ingelheim (Canada).

See: DDA. Dimakopoulos Wigglesworth architectes: Les laboratoires Bio-Mega. Agrandissements. See also: Daniel Renaud, "La SGF cède Bio-Méga au secteur privé." Finance 15 Aug. 1988: 6.

[281] Alain Marcoux et al, Musée d'art contemporain. Montréal. Esquisses soumises au concours d'architecture. (Quebec: Government of Quebec, August 1984). This design competition was launched by the Ministère des Travaux publics et de l'Approvisionnement headed by the Minister Alain Marcoux (b.1945) and mandatory of the Société Place des Arts presided by Guy Joron and the Ministère des Affaires Culturelles headed by Clément Richard. Contrarily to the precedent two-stage competitions involving pre-selected architectural & engineering consortia, this competition was opened to all members of the Order of Architects of Quebec. It was first announced publicly by Clément Richard on September 30, 1983.

[282] Alain Marcoux et al. The period of inscription lasted from December 2, 1983 until January 16, 1984. In addition to André Ménard, director of the museum, and Gérard Lamarche, director general of the Régie de la Place des Arts, the jury presided by Ray Affleck included Radoslav Zuk (b.1931), teaching at McGill, Gae Aulenti (b.1927), Italian architect of international reputation, Jacques Le Barbanchon and Jacques Audet, architectural representatives of Public Works and Cultural Affairs. The selection criterias were urban and architectural design excellence, integration to Place des Arts, accessibility from existing interior and exterior pedestrian facilities and respect of program and budget requirements.

[283] André Ménard et al, Architectures du musée. 1er Juillet - 16 Septembre 1984. Musée d'art contemporain de Montréal. Exhibition catalogue. (Montreal: Ministère des Affaires Culturelles, 1984).

[284] David Wigglesworth, fourth interview.

[285] David Wigglesworth, fourth interview.

[286] David Wigglesworth, fourth interview. The failures of the program were later acknowledged by the direction of the Musée d'art contemporain. Requesting a maximal view on the Salle Wilfrid Pelletier's colonnade from the south-west and the preservation of 75% of the adjacent green space to the north-west, this program generated squeezed

architectural solutions otherwise disqualifications.

In September 1984, the Board of directors of the museum requested a revision of the interior plans of the winning scheme designed by Gabriel Charbonneau of Jodoin Lamarre Pratte & associés. By January 1985, it was established that the competition program had not been properly articulated while its space requirements were insufficient. As a consequence, the construction was interrupted after the excavation works in August 1985.

By January 1986, a complete re-examination of the project was requested by the museum authorities and a construction moratorium was decreeted the next month. In December 1986, the latter was lifted while the definition process of a new program of requirements was elaborated by Guy Desbarats, acting as consulting architect. In parallel, major modifications to the initial concept were developed in three options by Gabriel Charbonneau of Jodoin Lamarre Pratte & associés.

In November 1987, the third JLP option was accepted by the Ministère des Affaires Culturelles and by June 1988, the new program of requirements was delivered. In September 1988, the final plans of the revised project were approved by the Quebec Government. Construction works were restarted in January 1990. The revised project was ultimately completed in Spring 1992. See: Marcel Brisebois, "Le Musée d'art contemporain." Vie des Arts No.145 (Winter 1991-2): 16-18. See also: Musée d'art contemporain de Montréal. La petite histoire de la construction du Musée d'art contemporain de Montréal Montreal: Musée d'art contemporain, 11 Jan. 1991: 1-2.

[287] Alain Marcoux et al 82-3. These pages included various plates from Dimakopoulos' project such as: Interior view, View from Sainte-Catherine Street, Plot plan and Façade on Sainte-Catherine Street.

[288] David Wigglesworth, fourth interview. They were identified as "Willy beams".

[289] Marcel Brisebois 16. While Gae Aulenti had left before the end of the deliberations, the jury's decision was later put into trial by Simon Cayouette (b.1936) of Cayouette & Saia, second prize winner, since Ray Affleck's current association on another project with the first prize winning firm generated a conflict of interest.

[290] Alain Marcoux et al, and André Ménard et al. The 1st prize of \$30,000 and



commission were awarded to Jodoin Lamarre Pratte & associés for the project designed by Gabriel Charbonneau. The 2nd prize of \$20,000 was awarded to Cayouette & Saia for the project designed by Mario Saia (b.1939). The 3rd prize of \$15,000 was awarded to Favreau Lapointe Magne LeMoyne & associés. The four other honourable mentions of \$5,000 were awarded to Reich & Martel, Larose Laliberté Petrucci, Zoya Duba and Semple Denis Dubé.

[291] André Ménard et al.

[292] David Wigglesworth, fourth interview. Formerly employed by Dimakopoulos, Alex Chu moved to Hong Kong where he worked for the Architects Partnership as Project architect for the Jing An Hilton Hotel Shanghai. Under his recommendation, the firm hired Dimitri Dimakopoulos & Partners as Consulting architects for the preliminary design. The rest of the project was implemented by the Architects Partnership.

[293] David Wigglesworth, fourth interview. See also: Cindic Hotel Investment Co. Ltd. Jing An Hilton Hotel Shanghai (Hong Kong: Cindic Hotel Investment Co. Ltd., 5 Sept. 1984): 1, 16. The Project managers were Cindic Consultants Ltd./The Great Eagle Project Management Ltd. This promotional brochure including the preliminary design was presented to the authorities of the city of Shanghai following coordination with the Shanghai Municipal Institute of Civic Architectural Design and various governmental departments.

[294] David Wigglesworth, fourth interview.

[295] David Wigglesworth, fourth interview. See also: Cindic Hotel Investment Co. Ltd. 15. During the course of this project, Dimakopoulos went to Hong Kong and Shanghai. As per: David Wigglesworth, fifth interview, February 7, 2001.

[296] Cindic Hotel Investment Co. Ltd. 2, 4.

[297] Cindic Hotel Investment Co. Ltd. 4.

[298] Cindic Hotel Investment Co. Ltd. 4-5. See also the podium floor plans.

[299] Cindic Hotel Investment Co. Ltd. 4-5. See also the podium floor plans.

[300] Cindic Hotel Investment Co. Ltd. 4-5 See also the podium floor plans.

[301] Cindic Hotel Investment Co. Ltd. 6. See also the tower floor plans.

[302] Cindic Hotel Investment Co. Ltd. 6, 13. See also the tower floor plans.

- [303] Some characteristics of the building design were inspired from Dimakopoulos' previous projects. While the vertical strips of bay-windows echoed the front façade of the Edifice La Laurentienne, the triangular plan and panoramic elevators running along a vertical shaft were architectural concepts previously used for the Concordia West complex. In general, the architectural treatment of the tower and podium was quite typical of Dimakopoulos' personal style developed during the 1970's and 80's.
- [304] Cindic Hotel Investment Co. Ltd. 7.
- [305] David Wigglesworth, fourth interview. Generating employment, the project also contributed to the urban revitalization of this strategic Montreal area.
- [306] Université du Québec à Montréal. Construction de la phase II du campus. (Montreal: Université du Québec, December 1986) 4.
- [307] René Viau, "L'UQAM ... ou le bain de jeunesse du quartier Saint-Jacques" 12. See also: Cécile Grenier and Joshua Wolfe 172.
- [308] Cécile Grenier and Joshua Wolfe 172. See also: Université du Québec à Montréal. Construction de la phase II du campus 7. This façade belonged to the former Centrale d'artisanat du Québec.
- [309] Université du Québec à Montréal. Construction de la phase II du campus. 4, 7.
- [310] David Wigglesworth, fourth interview. See also: Université du Québec à Montréal. Construction de la phase II du campus 7. The main entrances of the Pavillons des Sciences de la Gestion, Athanase-David and de la Musique were respectively located at 315, Ste-Catherine E., 1430, Saint-Denis, and 1440, Saint-Denis. See: Université du Québec à Montréal, Communiqué. En présence du maire de Montréal M. Jean Doré, Inauguration de trois nouveaux pavillons de l'UQAM (Montreal: UQAM, 5 June 1992) 1. While Willy Sung was mostly concerned with the graphic, plastic and functional aspects of the design, Gabriel Charbonneau acted as Project Architect for Jodoin Lamarre Pratte & associés, involved in functional planning, contract documentation and site supervision. As per: Louis Bellefleur, telephone conversation, 8 February 2001.
- [311] Université du Québec à Montréal. Construction de la phase II du campus 7. See also: Jean-Pierre Bonhomme, "La phase II de l'UQAM: un design correct sans plus." La Presse 23 Sept. 1990: B 7.

- [312] Université du Québec à Montréal. Construction de la phase II du campus 7. While the main entrance of the South Wing was located on Sainte-Catherine Street, two additional entrances were found on Saint-Denis Street and Place Pasteur.
- [313] Cécile Grenier and Joshua Wolfe 172. The extra storey was added in 1921 by Aristide Beaugrand-Champagne (1876-1950). It was followed by two successive expansions on Sanguinet Street in 1930 and 1942 by Charles David (1890-1962).
- [314] Université du Québec à Montréal, Communiqué 2. See also: Université du Québec à Montréal. Construction de la phase II du campus 7. In addition to the direct underground metro access, the two main entrances were located on Saint-Denis Street and de Maisonneuve Boulevard while a fourth one was giving on the interior court.
- [315] Université du Québec à Montréal, Communiqué 2.
- [316] Université du Québec à Montréal. Construction de la phase II du campus. While Willy Sung was responsible for the graphic, plastic and functional aspects of the design, Louis Bellefleur (b.1949) acted as Project architect for Jodoin Lamarre Pratte, involved in functional planning, contract documentation and site supervision.
- [317] Université du Québec à Montréal. Construction de la phase II du campus. A secondary entrance was located on Saint-Denis Street.
- [318] Université du Québec à Montréal, Communiqué. Inauguration du Pavillon Thérèse Casgrain, première étape de la phase II de construction du campus de l'UQAM (Montreal, UQAM, 5 October 1989): 1. See also: Université du Québec à Montréal. Construction de la phase II du campus.
- [319] Université du Québec à Montréal, Communiqué. En présence du maire de Montréal... 1.
- [320] Université du Québec à Montréal, Communiqué. Inauguration du Pavillon de l'Éducation (Montreal: UQAM, 13 October 1993): 1.
- [321] Université du Québec à Montréal, Communiqué. Inauguration du Pavillon de l'Éducation 1.
- [322] Jean-Pierre Bonhomme, "Le comité conseil de l'arrondissement Centre rejette le projet de l'UQAM." La Presse 19 Jan. 1990: A 4. See also: Jean-Pierre Bonhomme, "L'UQAM se déplace vers l'ouest pour relier ses deux campus." La Presse 22 April

1991: A 4.

[323] Université du Québec à Montréal, Communiqué. Inauguration du Pavillon de l'Éducation 1-2. While Willy Sung was responsible for the graphic, plastic and functional aspects of the design, Louis Bellefleur acted as Project architect for Jodoin Lamarre Pratte, involved in functional planning, contract documentation and site supervision.

[324] David Wigglesworth, fourth interview. While Wigglesworth acted as Coordination architect for Dimakopoulos & Partners, Jean Martin (b.1956) was the Project architect for Jodoin Lamarre Pratte & associés. As per Louis Bellefleur, telephone conversation, 8 February 2001.

[325] "6,000,000\$ pour la nouvelle salle de concert de l'UQAM." La Presse 2 Oct. 1990: B 7.

[326] Louis Bellefleur, telephone conversation, 8 February 2001. Originally working for Dimakopoulos on the project, Michel Aubé left him for Sceno-Plus where he redesigned the base building and concert hall following estimations that exceeded the budget.

[327] David Wigglesworth, fourth interview. The project was undertaken subsequently to a first study done by the Montreal scenographer Yvon Sanche.

[328] David Wigglesworth, fourth interview.

[329] David Wigglesworth, fourth interview. See also: "La Place des Arts en résumé." La Presse 23 October 1993: Cahier Spécial 13.

[330] David Wigglesworth, fourth interview.

[331] Denis Lavoie, "20 Millions \$ ont été investis au Théâtre Saint-Denis et à la Salle Wilfrid-Pelletier." La Presse 17 Feb. 1990: D 4. See also: Dimakopoulos Wigglesworth architectes: Salle Wilfrid Pelletier, agrandissement de l'arrière-scène, Place des Arts.

[332] Dimakopoulos Wigglesworth architectes: Rénovations de la Salle Wilfrid Pelletier de la Place des Arts. While the aging theatre equipment required modernization, the orchestra pit was enlarged to house 100 instead of 75 musicians and the back-stage to accommodate the scenes of many alternating operas. See: Mathieu-Robert Sauvé, "Théâtre sous surveillance." L'Actualité Vol.14 No. 6 June 1989: 153.

Almost 32 meters wide by 18 meters deep with a new right wing of 19 x 12 meters,

the new stage of Salle Wilfrid Pelletier was designed by the scenographers Bob Lorelli of Brannigan Lorelli Associates Inc., New York, and Patrick Berger of Scéno-Plus, Montreal, as the biggest multi-purpose stage in North America. Operated with a unique hydraulic system, the variable geometry orchestra pit allowed a 5-meter deeper proscenium by retracting the first three rows of seats. It could also be brought up to the level of the hall to accommodate a 100-musician orchestra during opera performances while both pit and proscenium could also disappear partly or completely.

Projecting the sound into the hall, a new louvre-board assembly wall covered with rosewood emerged from the floor and rose behind the orchestra while new lateral sound-shields in rosewood and new oak stage floor improved considerably the overall acoustics and aesthetics of the hall. See: Bernard Paré, "A stage that's up to standards." as well as: Marie Laurier, "La Salle Wilfrid Pelletier améliore tant son esthétique que son acoustique." Le Devoir 19 August 1991: 11.

[333] David Wigglesworth, fourth interview. Educated in Paris, this young Iranian architect only worked for a year at Dimakopoulos & Partners before returning to Iran. As originally conceived, the Grande Salle offered a sophisticated front and secondary back. The architectural emphasis of the building was oriented towards the Place des Arts itself while the back service façade giving on a secondary artery was at the time considered unimportant.

[334] Dimakopoulos Wigglesworth architectes: Salle Wilfrid Pelletier, agrandissement de l'arrière-scène, Place des Arts.

[335] David Wigglesworth, fourth interview. Because of the 1950's theories, the Grande Salle was originally designed as a polyvalent center for the performing arts. Due to its multi-purpose nature, the building however involved major compromises and the upgraded Salle Wilfrid Pelletier could not achieve the best performance in each discipline.

[336] Dimakopoulos Wigglesworth architectes: Salle Wilfrid Pelletier, agrandissement de l'arrière-scène, Place des Arts.

[337] David Wigglesworth, fifth interview, February 7, 2001. See also: Dimakopoulos Wigglesworth architectes: College Dawson Phase III Campus Atwater.

[338] David Wigglesworth, fifth interview. See also: Dimakopoulos Wigglesworth architectes: College Dawson Phase III, Phase IV and Phase III and IV. Campus Atwater. By early-1994, the consortium Dimakopoulos Tétrault & associés (Dimakopoulos Wigglesworth and Tétrault Parent Languedoc) was commissioned to design the \$18-million fourth and final phase of the Dawson College Atwater Campus. Laid out on rectangular plan with four partial interior courts and intermediate lower wing including classrooms, laboratories and links to Phase II above grade, the complex featured a large double-storey gymnasium in the basement below.

The program involved the relocation of the remaining programmes from the Selby Campus such as mechanical, civil and electrical engineering techniques. Housing the career programmes (office technologies, administrative and computer studies) in the above grade south-west pavilion, Phase IV also contained a triple gymnasium, a dance studio, weight room and other specialized accommodation in a new sports center.

While Dimakopoulos was totally uninvolved following his mid-1993 retirement, similarly to Sung who had left the office earlier in the year, Wigglesworth acted as Project architect for Dimakopoulos Wigglesworth, and Pierre Corriveau, from TPL, as job captain and project designer for the interior details and coordination. Following a quick design process, this last addition offered the same architectural quality, sensitivity and functionality than the three previous phases. Construction was completed in 1997.

[339] David Wigglesworth, fifth interview.

[340] David Wigglesworth, fifth interview. Dimakopoulos was also involved in the City of Westmount negotiations while most of the coordination with the client and Ministry of Cultural Affairs was done by Wigglesworth.

[341] David Wigglesworth, fifth interview. See also: Dimakopoulos Wigglesworth architectes: College Dawson Phase III Campus Atwater.

[342] David Wigglesworth, fifth interview. A new special by-law was written by the City of Westmount for that building.

[343] David Wigglesworth, fifth interview. Jodoin Lamarre Pratte & associés also contributed to the preparation of working drawings done at their main office under the supervision of Louis Bellefleur.

[344] David Wigglesworth, fifth interview.

[345] David Wigglesworth, fifth interview. Considering Dimakopoulos' office the best architectural design firm in Montreal, Bernard Lamarre first offered him the signature of the project consisting initially in two towers. On December 24, 1987, he offered to Gilles L. Larose, of Larose Petrucci, a joint venture commission as the Architect of record with a smaller participation of Lemay & associés (formerly Lemay Leclerc). Two months later, Larose Petrucci was also hired as local Architect of record to complement the American firm of Kohn Pedersen Fox designing the Marathon/IBM Building office tower, Montreal, 1988-92. As requested by his new client, Gilles L.-Larose had to resign from his earlier commission since his firm could not be involved in both projects. As a result, Le 1000 de La Gauchetière commission was completely seconded to George E. Lemay (b.1929) of Lemay & associés. As per Gilles L.-Larose, telephone conversation, January 16, 2001. See also: "Urban diplomat." Architectural Record May 1993: 75.

[346] Georges Renaud, "Montréal ... en pleine effervescence. Les grands projets. L'Edifice 1000 de La Gauchetière." Bâtiment Sept./Oct. 1988: 9.

[347] Michael Carin, "Dimitri Dimakopoulos. Take a downtown walk tour with a leading architect." Montreal Business Magazine June 1992: 30. Similarly to the René Lévesque Boulevard, the Dominion Square name was changed to Dorchester Square after the death of the former separatist Quebec Premier René Lévesque in 1987. Allowing beautiful perspectives, the building would close an opening at its south-east end. It would also offer spectacular interior views through its glazed envelope. From the great hall mezzanine, stunning perspectives would open respectfully on the venerable neighbour, melting in harmony with the circular rhythms of the lobby and the symbolical angular glazed archway of the main entrance. Featuring full-height panoramic office windows, the tower would allow spectacular diving views all around. From the five upper office floors located in the lower part of the pyramidal roof (floor #39 to #43), breath taking panoramic views were also provided by means of sloping windows.

[348] Georges Renaud 9. In August 1988, the 45-storey tower project included 2300 square meters per office floor and a 800-car underground parking garage. From 92,900 square meters, the total interior floor area of the built structure was ultimately reduced to

86,490 square meters (80,910 for offices and 5,580 for commercial space) putting it in fourth position for rentable office space in Montreal after #1, Place Ville-Marie, 1250, René Lévesque (Marathon/IBM Building) and Place Victoria. Similarly, the garage capacity was reduced to 650 cars. See: Jean-Luc Renaud, "L'important ce n'est pas d'être le plus gros, mais d'avoir une identification propre et distinctive." Les Affaires 26 August 1989: 41.

[349] David Wigglesworth, fifth interview. Bernard Lamarre originally wanted Le 1000 de La Gauchetière to be the heart of the new Montreal downtown core. Wishing an architectural design independent from foreign contemporary fashion, he convinced his partners of the pertinence of his project. As per: Geneviève Picard, "En plein dans le 1000." L'Actualité 15 May 1992: 46. See also: Georges Renaud, "Chronique commerciale. Les Grands projets. 1000 de La Gauchetière Ouest." Bâtiment May/June 1989: 9. See also: "To be Montreal's tallest building..." Canadian Building July/Aug. 1989: 5.

[350] David Wigglesworth, fifth interview. See also: François Rémillard and Brian Merrett, L'Architecture de Montréal. Guide des styles et des bâtiments. (Montreal: Editions du Méridien, 1990): 60. French Canadian bastion of catholicism, it reinterpreted at 1/3 smaller scale the architecture of Saint Peter's Cathedral in Rome. It also included some typical architectural elements of Montreal such as embossed granite masonry walls, granite front sculptures and copper roofs. At that time, the Neo-Renaissance style was considered appropriate to counter the Gothic Revival style associated with the Anglican religion since the completion of Christ Church Cathedral, 1440 Union Avenue, Montreal, 1857-9, by Frank Wills (1822-57).

[351] Geneviève Picard, "En plein dans le 1000." 46. This quotation originally stated in French was borrowed from Dimitri Dimakopoulos, Willy Sung and Olivier Legault. Without any explicit statement, it explained the strong contrast between the vernacular contextualist design approach of the Post-Modernist "Free-Style" Classical Le 1000 de La Gauchetière and the neutral international contextualist design approach for the Neo-Modern / Constructivist Marathon/IBM Building. The design of the latter was carried out in New York by Kohn Pedersen Fox simultaneously with two other similar towers for



Munich and Sydney.

[352] Jean-Pierre Bonhomme, “Un campanile pour la cathédrale catholique.” La Presse 22 Jan. 1989: C 3. Similarly to the Post-Modern Neo-Gothic Maison (Tour) des Coopérants, Montreal, 1986-88, by Webb Zerafa Menkès Housden, the more conservative Le 1000 de La Gauchetière was designed as an appendix to the French Canadian catholic cathedral. More frivolous with its pink reflective glass, the former was erected on de Maisonneuve Boulevard to dominate and integrate the anglican Christ Church Cathedral below. The contextualism used by Dimakopoulos was not only architectural and urban but also urbanistic, historical and religious, participating at urban scale to a new symbolical representation of the cultural duality of Montreal.

[353] David Wigglesworth, fifth interview. The lower cornice of the Sun Life Building, 1913-33, by Darling & Pearson, also suggested the podium roof height in accordance to the perspective along Dorchester Square on de la Cathédrale Street. See: Jean-Luc Renaud: 41.

[354] Jean-Pierre Bonhomme, “Un campanile pour la cathédrale catholique.” By January 1989, the budget for the whole project had increased to \$225 millions in order to beat in elegance, luxury and height the \$190-million and 50-storey Marathon/IBM Building rising only 196 meters. Illustrating power, the restrained Post-Modern “Free-Style” Classical silhouette of the new 205-meter tower would also exceed in height that of the former 174-meter Place Ville-Marie with its tapered pyramidal crown. At that time, the building design also featured a total of eight domes, including four smaller ones located at the corners of the 10th storey, but later abandoned.

[355] David Wigglesworth, fifth interview. While clients meetings and presentations were never held at Dimakopoulos’ office, Olivier Legault (b.1961), designated as Project architect and acting as Lemay’s representative, came to Dimakopoulos’ office from time to time, bringing some design ideas and reporting on complementary technical studies carried out at his office. By the end of the summer 1989, Lemay’s team was moving out from its main office located at 4001 Saint-Antoine into a project office located in the Edifice La Laurentienne, owned and mostly occupied by the Lavalin headquarters.

[356] David Wigglesworth, fifth interview. Christopher was the nephew of Arthur

Erickson.

[357] Jean-Pierre Bonhomme, “Un campanile pour la cathédrale catholique.”

[358] Michael Carin 31.

[359] The final design featured a 4-storey podium with 4-corner copper domes, a frontal glazed roof sided by two pyramidal skylights, two notched lateral terraces and a large terraced roof at the back with a conical glazed roof on axis above the skating rink. The second lateral set-back was found six storeys higher along the shaft, and the third one four storeys further up. Further notches stepping down towards a vertically continuous glazed strip on axis were found in the upper part of the front shaft elevation.

[360] David Wigglesworth, fifth interview. Inspired from a contemporary Texan office tower featuring an opened square hole near the top of the curtain wall, the arcuated bay-window device of Le 1000 de La Gauchetière which was originally functional turned out to be only ornamental in the final stage, following the client’s decision to change back the floor use to regular column-free office space.

[361] Jean-Pierre Bonhomme, “Un campanile pour la cathédrale catholique.” By January 1989, it had been decided that the tower shaft would be covered with an expansive grey and pink/beige Saguenay granite curtain-wall envelope.

[362] Geneviève Picard “En plein dans le 1000.” L’Actualité 15 May 1992: 48. The interior skating rink concept originated from an earlier project submitted to Bernard Lamarre by Olivier Legault. Complemented by the 1600-place Bell Amphitheater, it would allow free skating all year round and accomodate large shows on ice. See also: Geneviève Picard, “L’architecte le plus haut en ville.” L’Actualité 15 may 1992: 50.

[363] Robert Prévost “Le 1000 de La Gauchetière.” Actualité Immobilière Vol. XV No. 3 Autumn 1991: 43. The main floor plan followed a Beaux-Arts like composition.

[364] Jean-Luc Renaud 41. Offering a transition between the tower and the street, the podium was also used to absorb the turbulence created by winds striking the tower.

[365] David Wigglesworth, fifth interview. See also: “Lavalin pourrait ne jamais déménager dans son nouveau siège social.” Les Affaires Cahier spécial. 15 Sept. 1990: B 2. See also: “Lavalin songe à réduire ses investissements immobiliers.” Les Affaires Vol. 62 No. 38 29 Sept. 1990: 75. See also: “La crise actuelle frappe plus durement les

propriétaires.” Les Affaires 13 April 1991: B 2. Generating a major increase of new office space in Montreal, Le 1000 de La Gauchetière and the Marathon /IBM Building had become more difficult to rent during the economical crisis.

[366] Geneviève Picard, “En plein dans le 1000.” 48. As early as Fall 1989, a steel rather than concrete structure on the perimeter complemented by a concrete core had been selected by the structural engineers to reduce the expenses. See: Mariane Favreau, “Le futur gratte-ciel, rue de La Gauchetière, sera terminé dans les délais prévus.” La Presse 1st Nov. 1989: A 8. Similarly to the Eiffel Tower, Paris, 1889, by Gustave Eiffel (1832-1923), the building necessitated 9,000 tons of steel for its superstructure erected in 318 days.

In addition, 16,000 tons of concrete and 37,000 square meters of granite were required for a building equipped with 22 ultra-modern high-speed elevators distributed in three banks, 2 service elevators, 4 parking elevators and 10 escalators serving the podium. The building was also equipped with a “long boom” window washing arm rotating 360 degrees above the roof and disappearing in it when at rest. See: Robert Prévost 37, 40.

[367] “Report.” Canadian Building. Reda Directory. Dec.-Jan. 1994: 24-5. In May 1992, Brookfield Development Corporation proceeded to the purchase of the Prodevco-Lavalin shares in the project. By then, it held a 70% equity in the project while Teleglobe Canada Inc. remained partner at 30%. Resulting from the team work of 33 Québécois architects with an average age of 30 years old, the building was completely designed and built in French. In addition to Dimakopoulos, Sung and C. Erickson, the architectural team included Olivier Legault, André Major, Jocelyn Larue and Louis Lemay all associated with George-E. Lemay. See also: Geneviève Picard, “En plein dans le 1000” 46.

[368] Robert Prévost 37. While the building rose 51 storeys off the ground on Saint-Antoine Street, it rose only 49 storeys on de La Gauchetière Street, due to a strong sloping denivellation between the two. See: Robert Prévost 41. See also: Geneviève Picard, “En plein dans le 1000.” 46.

[369] David Wigglesworth, fifth interview. Since the completion of Place Ville-Marie in 1962, the Maison (Tour) des Coopérants, Le 1000 de la Gauchetière and the Marathon/IBM Building were the most spectacular towers to be added to the Montreal skyline.

Visible from the Champlain Bridge, the Ville-Marie Expressway and the Mount Royal lookout, the svelt but severe tapered vertical structure offered dramatic perspectives on its pyramidal crown from closer approaches to the city's core especially when driving down Chemin Côte-des-Neiges. See: Michael Carin 30-1. See also: "Reda 1993. Regional Reports. Quebec." Canadian Building Reda Directory. Dec.-Jan. 1993: 33.

[370] David Wigglesworth, fifth interview.

[371] Parachèvement du quadrilatère de la Place des Arts. (Montreal: Société Place des Arts, c.1993): 1.

[372] Parachèvement... 2,3. A sculpture-installation by Pierre Granche (1948-97) was installed in the open air atrium marking the underground junction between Place des Arts and the museum. Used as a skylight pit, another sculpture-installation by Claude Bettinger (b.1942) featuring a telescope-like cupola was located near the exit stairwells facing the Concert Hall colonnade.

[373] David Wigglesworth, fifth interview. The jury included Guy Morin, Chairman of the Board of Directors of the Société Place des Arts, and Guy Chenevert, architect representing the Quebec Ministry of Culture. However, it was not a formal jury and the decision was taken behind closed doors. The project of Dimitri Dimakopoulos & Partners was identified as the best conceptual study proposal.

[374] Jean-Pierre Bonhomme, "La Place des Arts aura sa vraie place urbaine." La Presse 5 May 1991: B 7. Traditionally, a place or plaza is an urban space publicly accessible from four sides, allowing pedestrian convergence and acting as a meeting place with many passers-by. In reality, the new Place des Arts was not a plaza but a frontal terrace and exterior court.

[375] Dimakopoulos Wigglesworth architectes: Parachèvement du quadrilatère de la Place des Arts.

[376] David Wigglesworth, fifth interview.

[377] David Wigglesworth, fifth interview.

[378] Jean-Pierre Bonhomme, "La Place des Arts aura sa vraie place."

[379] Parachèvement 2. It would be the ideal location to install the great stage for the Montreal summer jazz festival called "Le festival de jazz de Montréal."

- [380] Parachèvement... 2.
- [381] Parachèvement... 2.
- [382] Dimakopoulos Wigglesworth: Parachèvement du quadrilatère de la Place des Arts.
- [383] Parachèvement... 2.
- [384] Parachèvement... 2. This atrium is referred in the text as an exterior court.
- [385] Dimakopoulos Wigglesworth architectes: Parachèvement du quadrilatère de la Place des Arts. The excavation and site works were carried out by Beaver Cook Leitch Construction Ltd.; they were followed by Hervé Pomerleau Inc., acting as general contractor; finally, the interior works were carried out by Sajo Construction. As per David Wigglesworth, fifth interview. See also: Jean-Pierre Bonhomme, "La Place des Arts aura sa vraie place urbaine." See also: Daniel Rioux, "Le quadrilatère de la Place des Arts est remis à la population." Le Journal de Montréal 28 May 1993: 34.
- [386] Daniel Rioux 34. See also: Jocelyne Lepage, "Trente ans plus tard, les Montréalais ont leur place des uns et des autres." La Presse 28 May 1993: C 1. For the occasion, champagne and fancy biscuits were distributed to the public. Although affected by cancer, Dimakopoulos assisted to the ceremony with Wigglesworth. On the same occasion was inaugurated the exterior garden of sculptures of the Musée d'art contemporain. See also: Marie Laurier, "Connaissez-vous la place de tout le Mmonde?" Le Devoir 28 May 1993: A 3.
- [387] Jocelyne Lepage C 1.
- [388] Dimakopoulos Wigglesworth architectes: Deux résidences. The other projects of secondary importance of the 1980's included: Simpson's Store, Halifax, 1980-81; Guttman Residence exterior landscaping, Montreal, 1980; Expansion of the Résidence du Gouverneur Général à la Citadelle, Quebec City, 1981-83 (with Guy Desbarats); Lycée Outremont expansion, Montreal, 1981-82; Renovations to Dominion Gallery, Montreal, 1982; Université de Montréal Library Building, Montreal, 1982-83 (with Jodoin Lamarre Pratte & associés); Ryadh Theatre project, Saudi Arabia, 1982; Residence Kiki Politis, New York City, c.1983; Le Concorde-Quebec Hotel renovations, Quebec City, 1983-87; Doctor Penfield residential complex study, Montreal, 1984; Centre de Ski Morin

Heights project, Morin Heights, 1985; Landscape/Island/Bahrain project, Bahrain, 1986; Club Multisports du Saint-Laurent project, Ile Sainte-Catherine, 1986; Montreal diocese new offices interior design, Montreal, 1986-89; Renovation of Christ Church Cathedral, Montreal, 1986-89; Hydro-Quebec headquarters expansion urban study competition, Montreal, 1986; Renovation of main hall at No.5, Place Ville Marie, Montreal, 1988-91; Renovations to Raymond Dewar Institute, Montreal, 1988-89; Sainte-Catherine Street wind and micro-climate study, Montreal, 1988-89.

[389] Dimakopoulos Wigglesworth architectes: Deux résidences.

[390] David Wigglesworth, fifth interview.

[391] David Wigglesworth, fifth interview. See also: Dimakopoulos Wigglesworth architectes: Deux résidences.

[392] Dimakopoulos Wigglesworth architectes: Deux résidences.

[393] David Wigglesworth, fifth interview. See also: Dimakopoulos Wigglesworth architectes: Deux résidences.

[394] Dimakopoulos Wigglesworth architectes: Deux résidences.

[395] David Wigglesworth, fifth interview.

[396] David Wigglesworth, fifth interview.

[397] David Wigglesworth, fifth interview. See also: Dimakopoulos Wigglesworth architectes: Complexe Hotelier, Mala Strana, Prague. The Vlatva river was also called the Charles river.

[398] Dimakopoulos Wigglesworth architectes: Complexe hotelier, Mala Strana, Prague.

[399] David Wigglesworth, fifth interview.

[400] David Wigglesworth, fifth interview. See also: Dimakopoulos Wigglesworth architectes: Complexe hotelier, Mala Strana, Prague.

[401] David Wigglesworth, fifth interview. The Sokol was a century-old institution operated by the former Communist government. At the time of the project, it was trying to recuperate its former buildings.

[402] David Wigglesworth, fifth interview. See also: Dimakopoulos Wigglesworth architectes: List of commissions.

[403] David Wigglesworth, fifth interview. Norman Nerenberg was accompanying them. Following various claims, a lot of time was spent trying to find out who owned the buildings among the various participants.

[404] Dimakopoulos Wigglesworth architectes: List of commissions. The projects of secondary importance of the 1990's included: Complexe Décarie Urban Design Study, Montreal, 1990; Renovation and restoration of the vieux Palais de Justice de L'Assomption, L'Assomption, 1990; Renovation and exterior design of Les Appartements Port-Royal Inc., Montreal, 1990; Renovations to former ICAO Building, Montreal, 1990-92; Expansion of the Bio-Mega Laboratories, Laval, 1990-93; Ecole Rivière-des-Prairies, Rivière-des-Prairies, 1991-93; Montreal Olympic Stadium new roof project, Montreal, 1992; Highway 30 outline territorial study, Montreal South Shore, 1992; Arbitration for Hôtel du Lac Carling, Lake Carling, 1993; Centre de recherche en neurobiologie de l'Hopital de l'Enfant Jésus conceptual study, Quebec City, 1993 (with Emile Gilbert & Ass. and Soucy Lessard).

[405] David Wigglesworth, fifth interview. Acting as Project architect, Wigglesworth carried out completely by himself this project for the Protestant School Board of the Greater Montreal. While Dimakopoulos was only involved two or three hours in the conceptual studies, Sung gave on occasions some consulting advices.

[406] David Wigglesworth, fifth interview.

[407] David Wigglesworth, sixth interview in Montreal on February 27, 2001. Winner of a competition he had entered without Dimakopoulos' knowledge, Sung left for the Republic of China to join a new firm and worked for two years on a new town and harbour development project. By the end of the decade, he was still working there. His departure decision had been taken in relation to a very bleak market prospect for Montreal.

[408] David Wigglesworth, fifth interview. André Blouin was the founder and major partner of Blouin & Blouin architectes (1966) later called Les Architectes Blouin Faucher Aubertin Brodeur Gauthier, located at 5423, de Lorimier Avenue, suite #200, Montreal. Owning the renovated building in which they worked, Blouin rented a small vacant office formerly occupied by Guy Gérin-Lajoie architecte for a few years before his 1992

retirement.

[409] David Wigglesworth, fifth interview. The two major long term projects carried out by Dimakopoulos Wigglesworth architectes were the Dawson College Phase IV, Montreal and Westmount, 1994-97, and the New expansion of the Bio-Mega Laboratories, Laval, 1995-97. The other commissions included: Académie Laurenhill expansion, Ville Saint- Laurent, 1993-94; Hôpital pour enfants de Montréal module 5 expansion conceptual study, Montreal, 1993; Nerenberg residence, Mont-Tremblant, 1995; Stasiak residence, Westmount, 1996-97.

[410] David Wigglesworth, fifth interview.

[411] David Wigglesworth, fifth interview. Married since more than three years to Willem Van Doesburg, architect, and residing normally in Vancouver, Marina and her husband took care of her father with her sister Irene, still unmarried at the time, as well as their mother Lydia.

[412] David Wigglesworth, fifth interview.

[413] David Wigglesworth, fifth interview. See also: "Celebrated architect designed many of Montreal's downtown landmarks." The Gazette 9 Nov. 1995: A 5.

[414] "Décès, prières, remerciements. Dimitri Dimakopoulos." La Presse 8 Nov 1995: A 19.

[415] Dimakopoulos Wigglesworth architectes: Résidence Stasiak.



## ENDNOTES

### CONCLUSION

- [1] Pierre Théberge et al, L'Architecture de Edward & W. S. Maxwell (Montreal: Musée des Beaux-Arts, 1991) 17-19.
- [2] France Vanlaethem et al, "Ernest Cormier 1885-1980." Architecture Québec ARQ No.53 (Feb. 1990): 7-29. See also: Pierre-Richard Bisson, "J.O. Marchand. Notes biographiques et pré-inventaire de l'oeuvre." Architecture Québec ARQ No.31 (June 1986): 18-21.
- [3] Jean Sutherland Boggs et al, "Twelve proposals for the National Gallery of Canada and for the National Museum of Man. Biographies." Section A Supplement (August 1984): 46-47. In addition to these five Canadian leading figures, a few others could be mentioned such as Ron Thom (b.1923), Douglas Cardinal (b.1934), Barton Myers (b.1934) and Peter Rose (b.1943).
- [4] By the late 1980's, Dan Hanganu (b.1939) became a competitor of Dimitri Dimakopoulos with a strong architectural design reputation in Montreal and the Province of Quebec built from a succession of local architectural awards.
- [5] Kieran Simpson Editor, Canadian Who's Who Vol. 17 (Toronto: University of Toronto Press, 1982):276. Soon after his adhesion to the PQAA, Dimakopoulos became a permanent member of the Association of Architects of Ontario. Following a regular membership, he became a Fellow of The Royal Architectural Institute of Canada in 1973 as well as an Academician of the Royal Canadian Academy of the Arts during the same year. By 1985, he was nominated Chevalier of the Ordre National du Québec. During his busy life, he also acted as director of the Canadian Hellenic Trust. He was also president of the National Capital Commission Committee of Design in 1981-2. Finally, he was a member of the Hellenic College Board of Directors of United States in 1975 and of the Canadian Archaeological Institute Academic Committee in Athens in 1980.
- [6] Eva Vecsei, answers to questionnaire written on April 30, 2000.
- [7] David Wigglesworth, sixth interview in Montreal on February 21, 2001.
- [8] Nikolaus Pevsner, An Outline of European Architecture 7th. Reprinted Ed. (London, Penguin Books, 1990). See also: John Julius Norwich, General Editor, Great

Architecture of the World (New York: Bonanza Books, 1978).

[9] H. W. Janson and Anthony E. Janson, History of Art Revised Fifth Ed. (New York Harry N. Abrams Inc., 1997): 490-93. See also: Hugh Honour & John Fleming, The Visual Arts. A History (New Jersey: Prentice Hall, 1995): 474-5.

[10] David Wigglesworth, sixth interview.

[11] David Wigglesworth, sixth interview. See also: Janson and Janson 459-71.

[12] James S. Ackerman, Palladio (London: Penguin Books, 1966, 1991): 160-186.

[13] Jean-François Revel et al, L'Architecture du XXe siècle (Lauzanne: Julliard, 1964): 24-33.

[14] Jean-François Revel et al 24.

[15] David Wigglesworth, sixth interview.

[16] Among them should be mentioned High Moderns such as Eero Saarinen, Oscar Niemeyer (b.1907), Louis Khan (1901-74), Kenzo Tange (b.1913) and Paul Rudolph (1918-97). Of a younger generation, Renzo Piano (b.1936), Richard Rodgers (b.1933), Norman Foster (b.1935), Richard Meier (b.1934), James Stirling (1926-92) and Cesar Pelli (b.1926) should also be mentioned amongst many others. As for the Post-Moderns, Michael Graves, Ricardo Bofill (b.1939), Aldo Rossi (1931-97), Hans Hollein (b.1943), Arata Isozaki as well as Frank O. Gehry (b.1929) and a few others gained also a much wider international reputation than Dimitri Dimakopoulos.

[17] David Wigglesworth, sixth interview.

[18] This was clearly expressed in the design of the UQAM Phase II buildings as well as in Le 1000 de La Gauchetière.

[19] This was particularly evident in the Greek Orthodox Cathedral and the Norman Wade Building.

[20] A truly Late-Modernist design, L'Edifice La Laurentienne was soon followed by the Bio-Mega Laboratories, his first attempt in the Post-Modern mode.

[21] The first Post-Modern building designed by Arthur Erickson was the Canadian Chancery, Washington, 1982-89. The first by Eberhard Zeidler was the Toronto Eaton's Center, 1970-79, by Bregman & Hamann and the Eberhard Zeidler Partnership. That of Moshe Safdie was the Jean-Paul Desmarais Pavilion of the Montreal Museum of Fine

Arts, 1987-91, by Safdie/Lemay Leclerc/Desnoyers Mercure, on which design I participated. All of them had previously worked in the Modernist mode since the 1960's.

[22] Michael Carin 32.

[23] David Wigglesworth, sixth interview.

[24] David Wigglesworth, sixth interview.

[25] The latter qualifications applied particularly well in the Greek Orthodox Cathedral and Le 1000 de la Gauchetière.

[26] David Wigglesworth, sixth interview.

[27] David Wigglesworth, sixth interview.

[28] David Wigglesworth, sixth interview.

[29] Guy Desbarats, Three views. According to him, this would have been at the origin of his lesser architectural achievements during the second part of his career.

[30] David Wigglesworth, sixth interview. On occasions, the design development or project administration would go to other employees if his two partners were too busy.

[31] David Wigglesworth, sixth interview.

[32] David Wigglesworth, sixth interview.

[33] David Wigglesworth, sixth interview.

[34] Michael Carin 32.

[35] David Wigglesworth, sixth interview.

[36] David Wigglesworth, sixth interview.

[37] David Wigglesworth, sixth interview.

[38] David Wigglesworth, sixth interview. See also: Guy Desbarats, Three views.

[39] David Wigglesworth, sixth interview. See also: Guy Desbarats, Three views.

## ILLUSTRATIONS

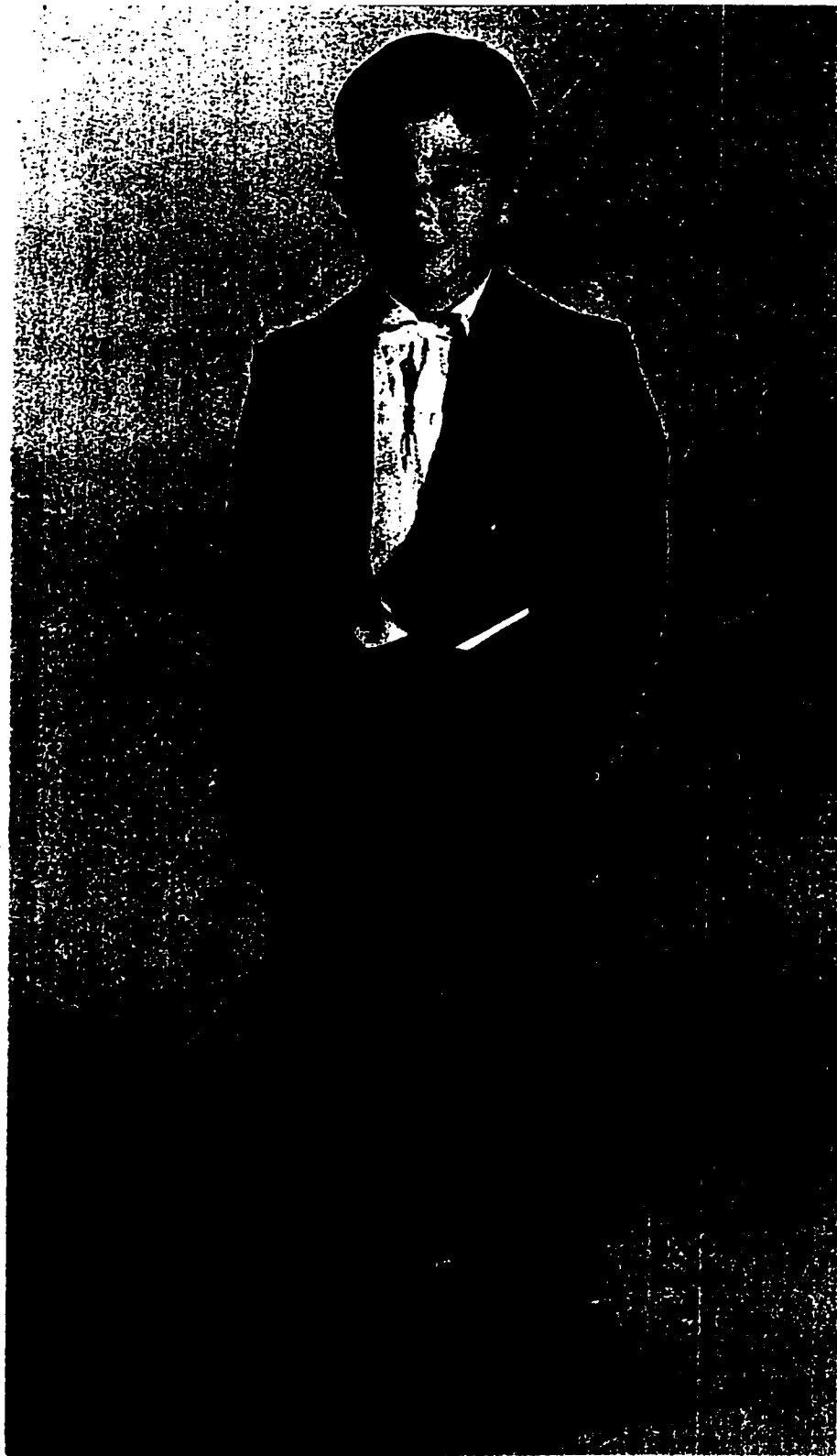

Fig. 1. Dimitri at about 7 years old in Athens, c.1936.

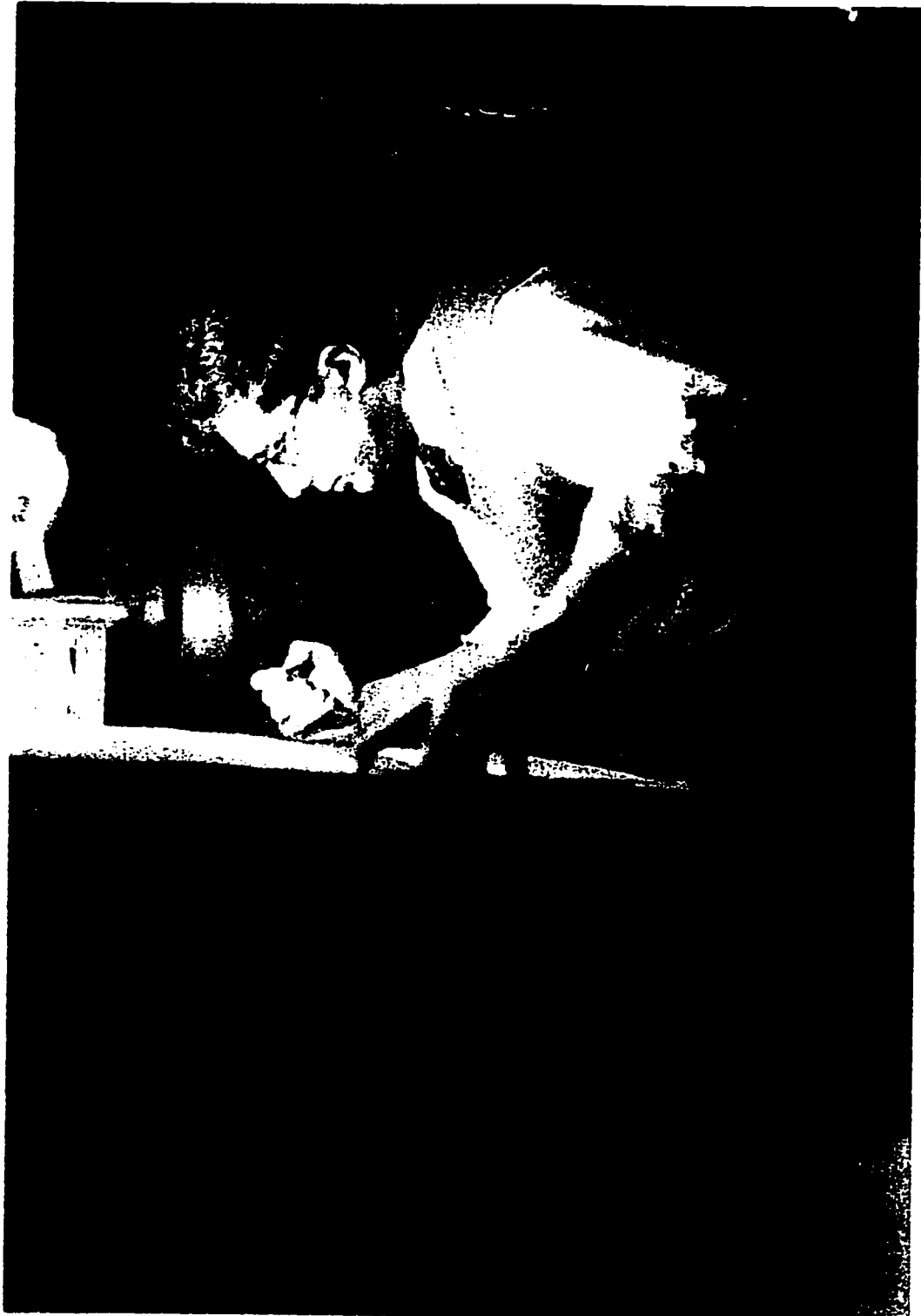

Fig. 2. Draughting during the McGill University Years (1949-55).



Fig. 3. Sketching during the McGill University Years (1949-55).



Fig. 4. Relaxing during the McGill University Years (1949-55).





Fig. 5. Wedding at St. Peter and St. Paul Church, Montreal, June 5, 1955.



Fig. 6. Wedding Reception in Montreal on June 5, 1955.



Fig. 7. Graduating at McGill University on May 25, 1955.



Fig. 8. Lydia and Dimitri at the McGill University Graduation.

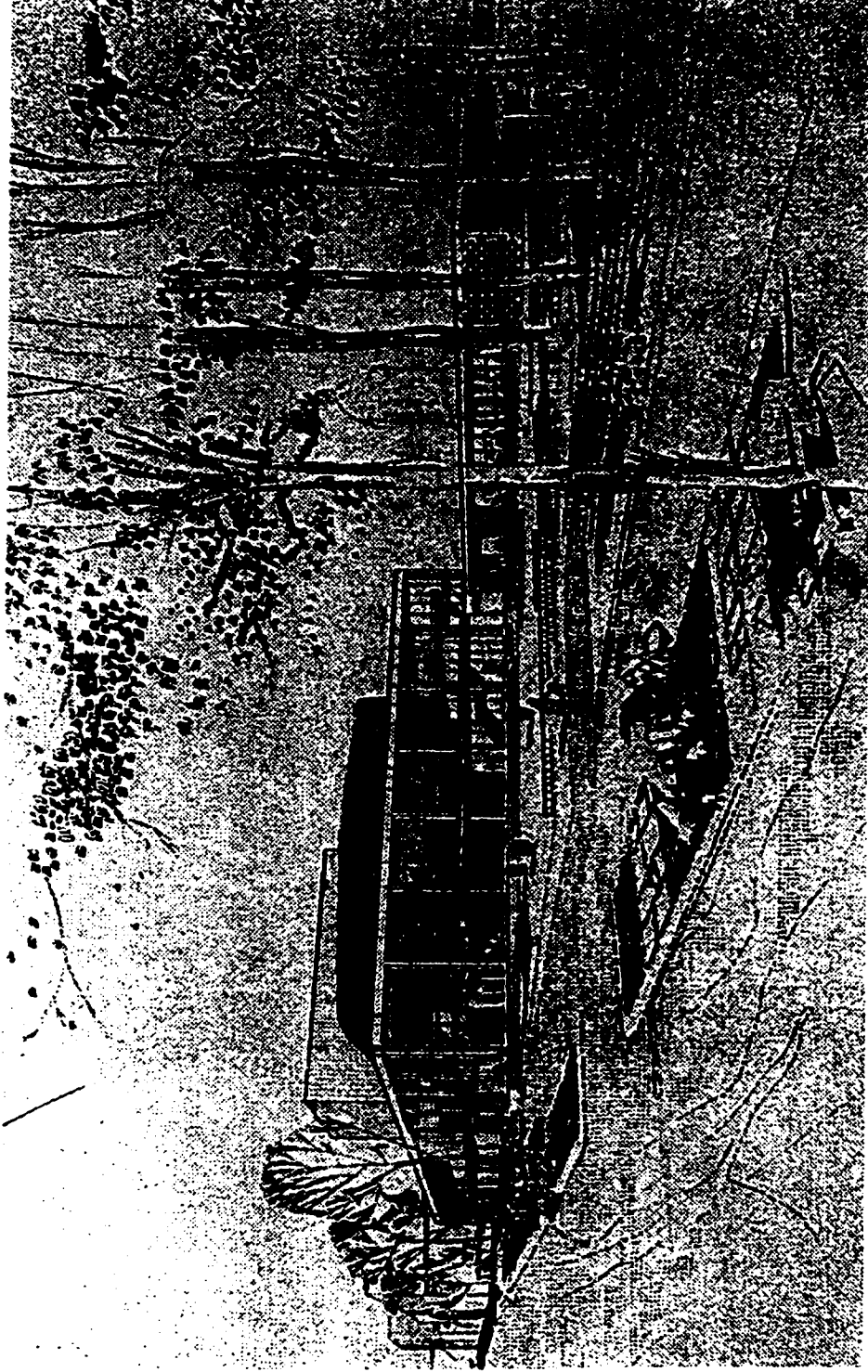

Fig. 9. Perspective. Vancouver Civic Auditorium Competition, 1955.

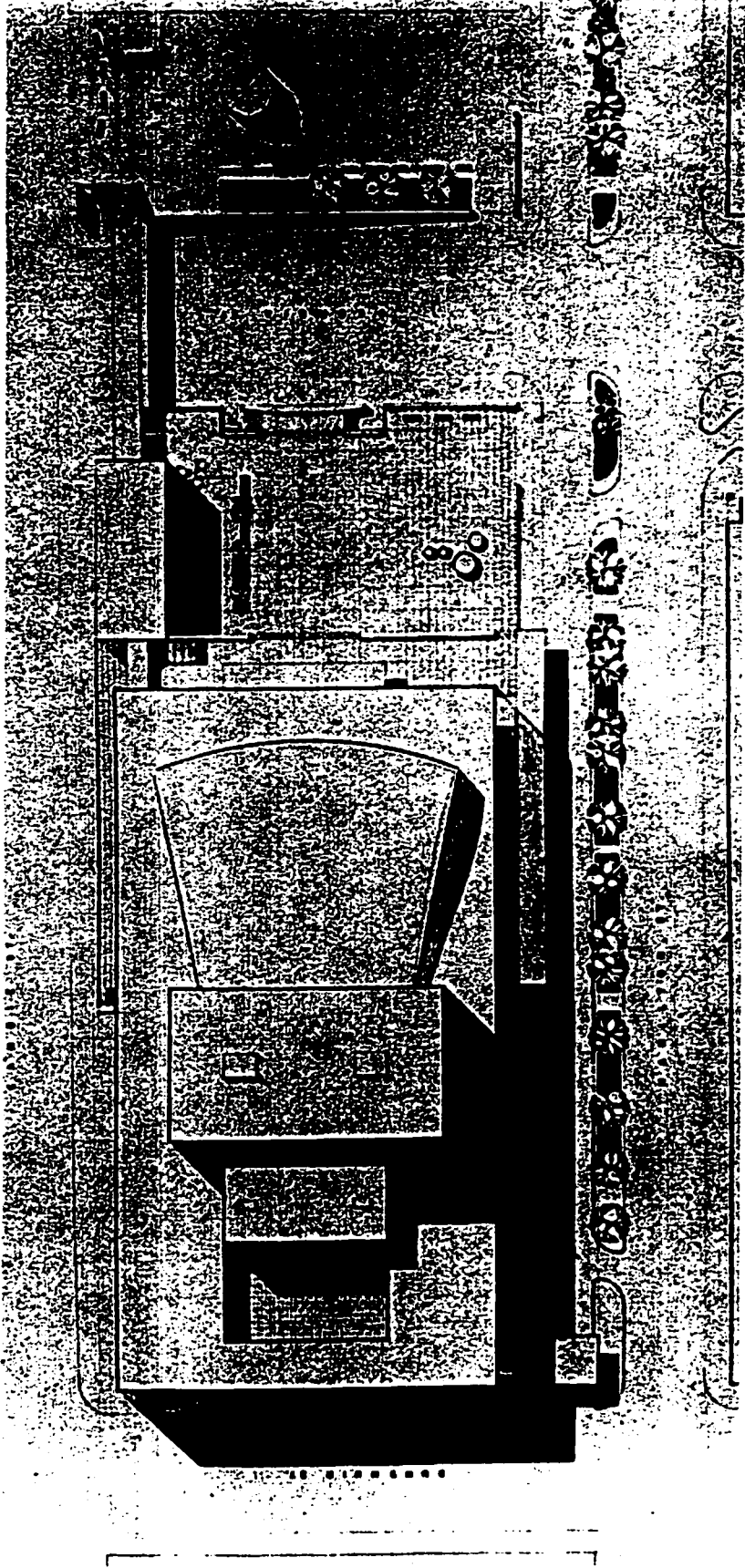

Fig. 10. Site Plan. Vancouver Civic Auditorium Competition, 1955.

1 Hazen Sise. 2 Jean Michaud. 3 Ray Affleck. 4 Guy Desbarats. 5 Dimitri Dimakopoulos. 6 Fred Lebensold.

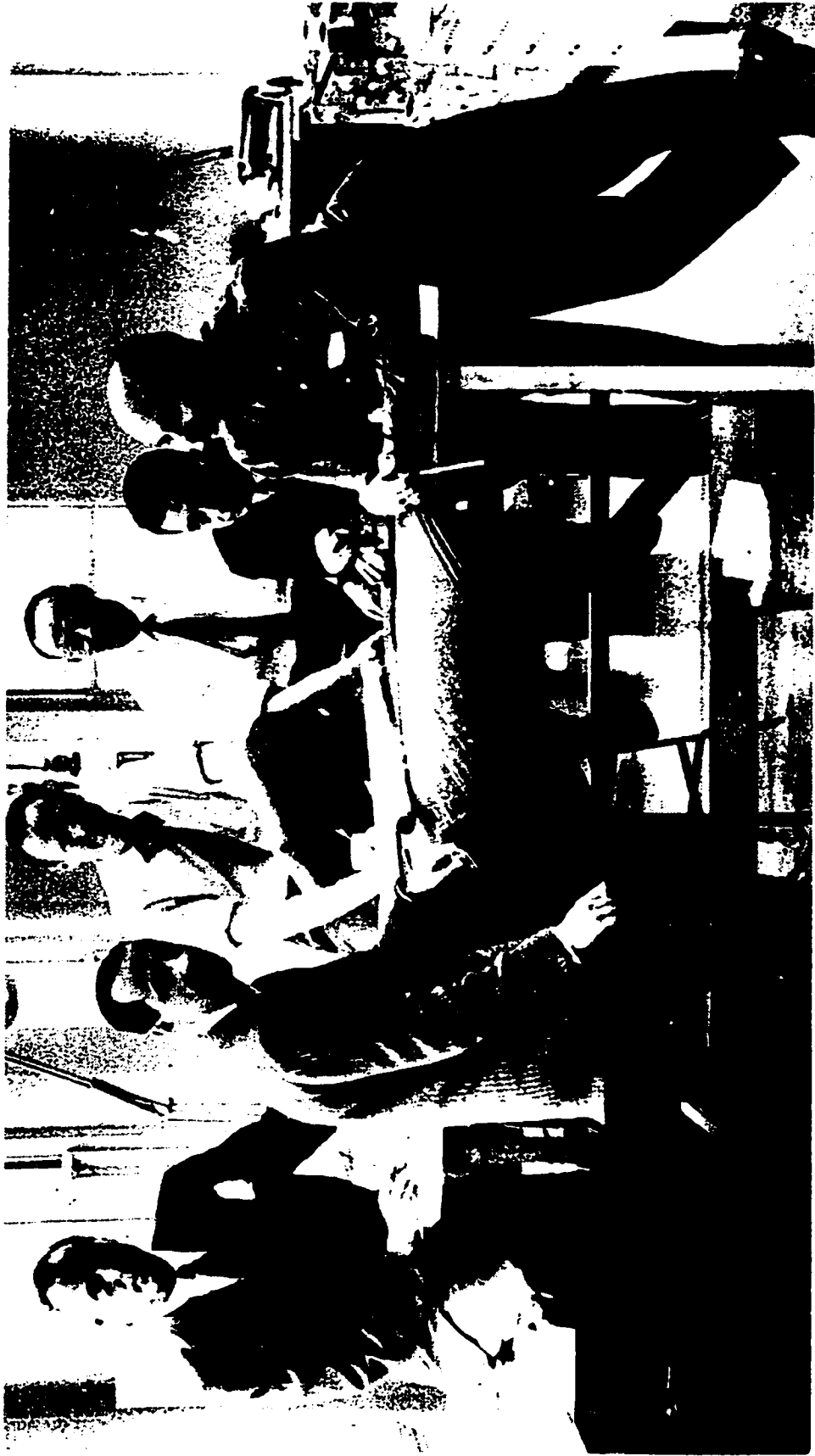

Fig. 11. The 6 ADDLMS Architects of the Vancouver Civic Auditorium.

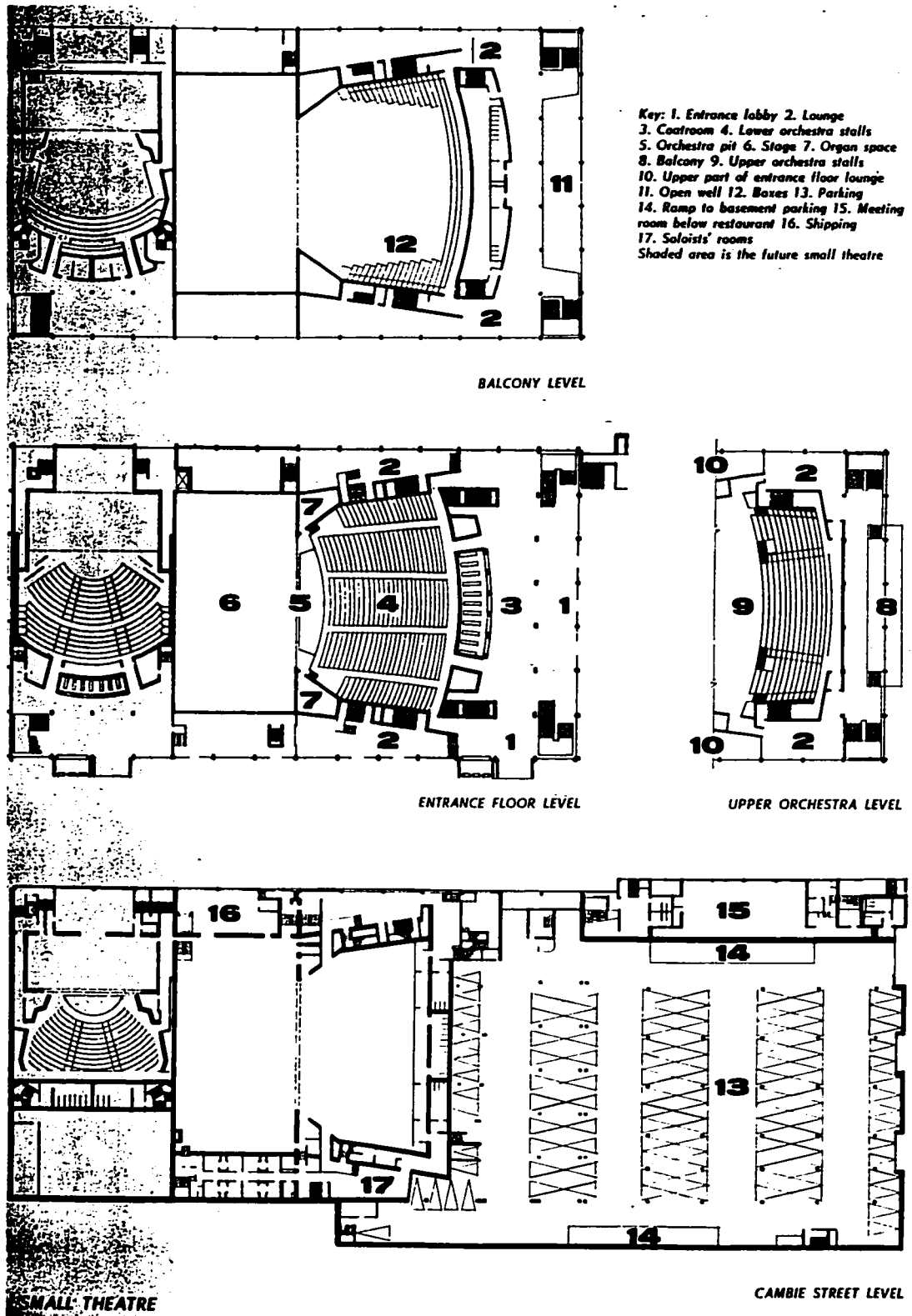

Fig. 12. Revised Plans. Queen Elizabeth Theatre, Vancouver, 1955-60.



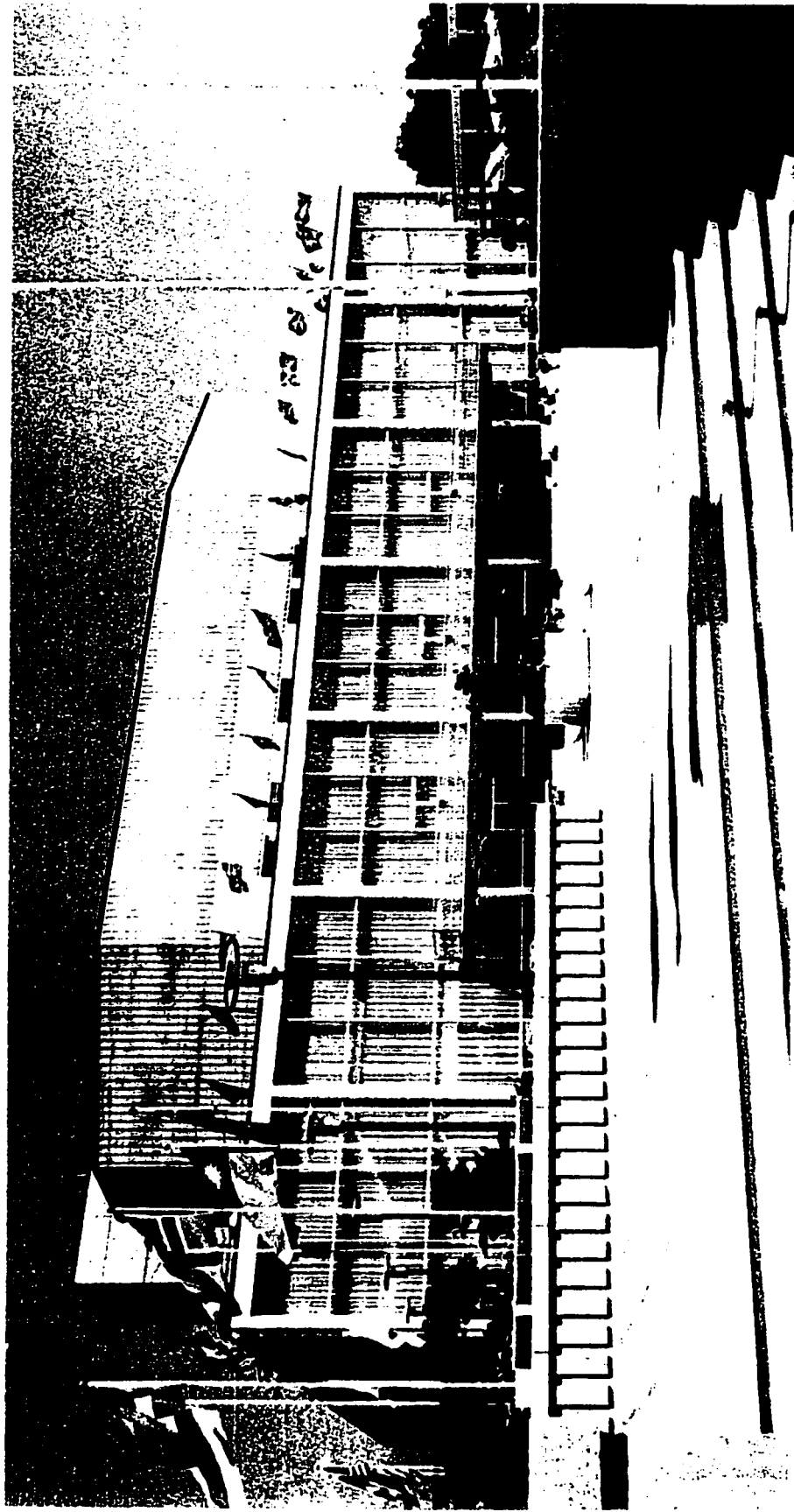

Fig. 13. Opening of the Queen Elizabeth Theatre, Vancouver, July 1959.



Fig. 14. Main Façade. Drummond Plaza Apartments, Montreal, 1957-8.

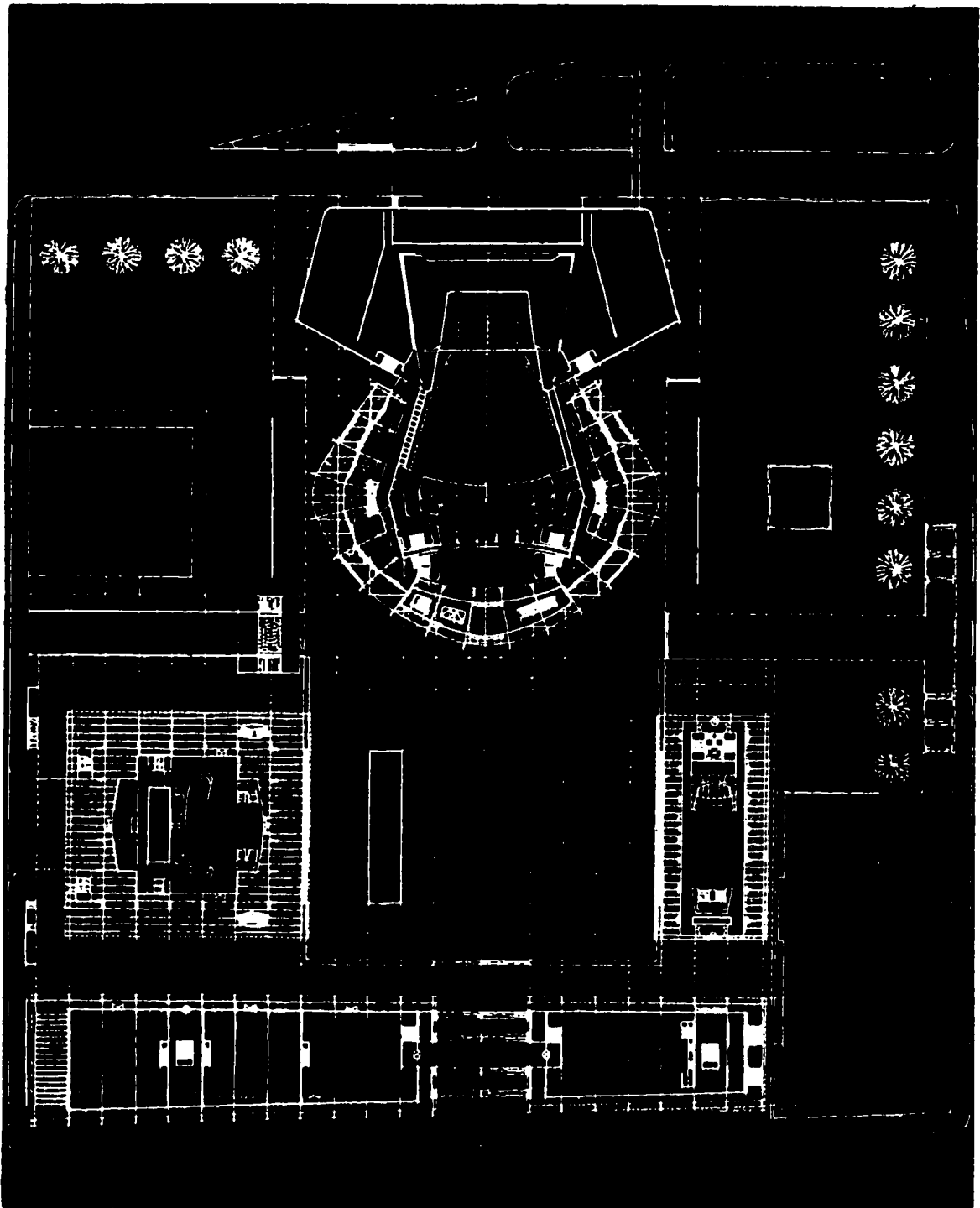
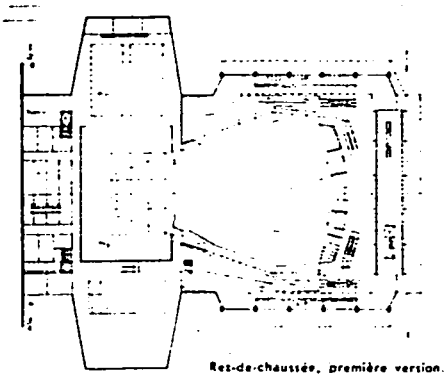
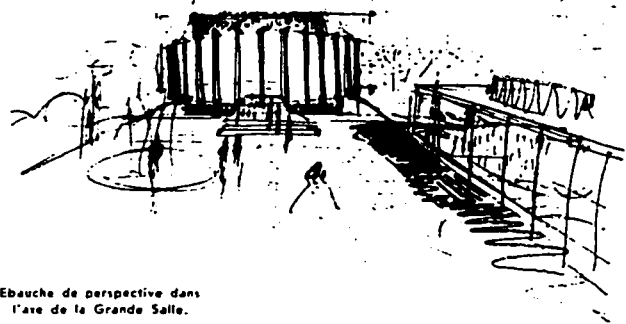

Fig. 15. Second Version of the Place des Arts Masterplan, Montreal, 1958.



Rez-de-chaussée, première version.



Ebauche de perspective dans l'axe de la Grande Salle.

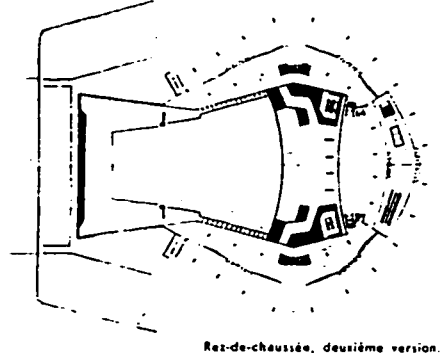

Rez-de-chaussée, deuxième version.

Rez-de-chaussée, troisième version.

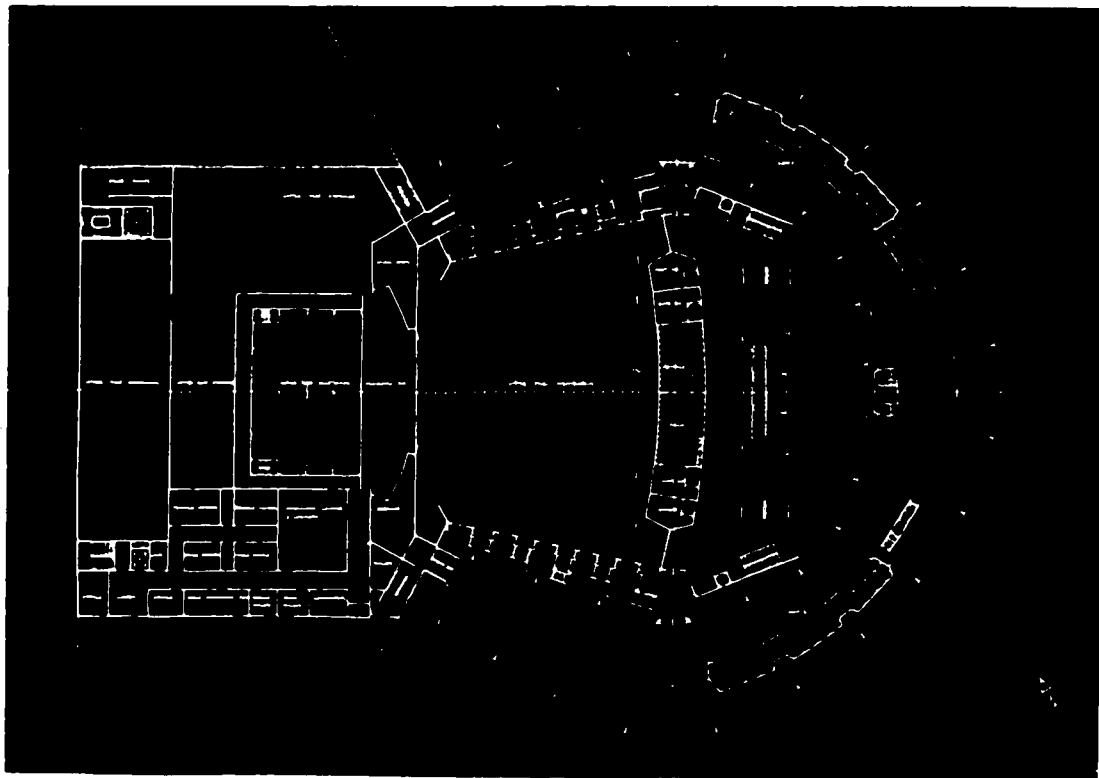
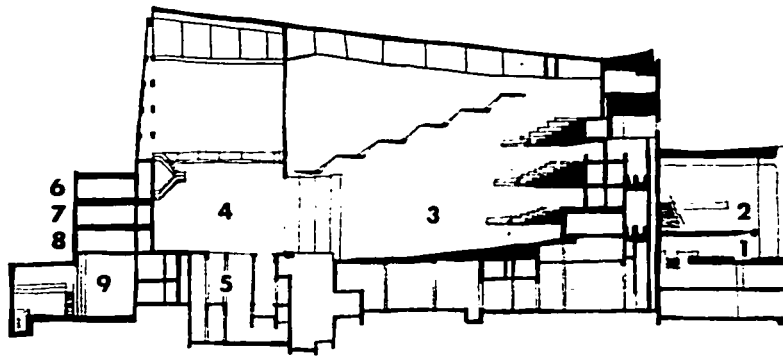
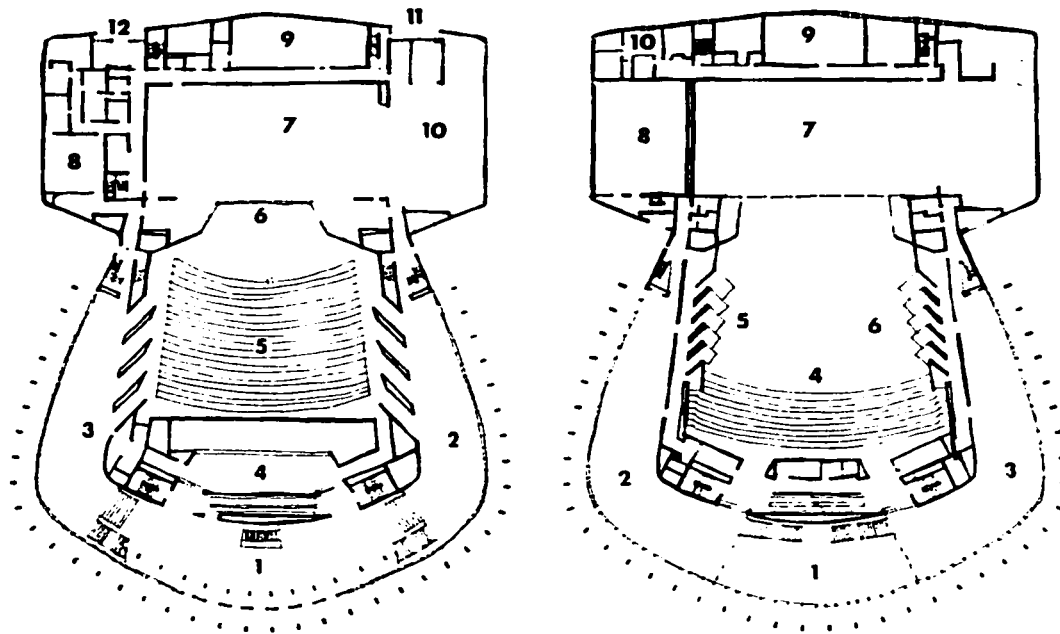
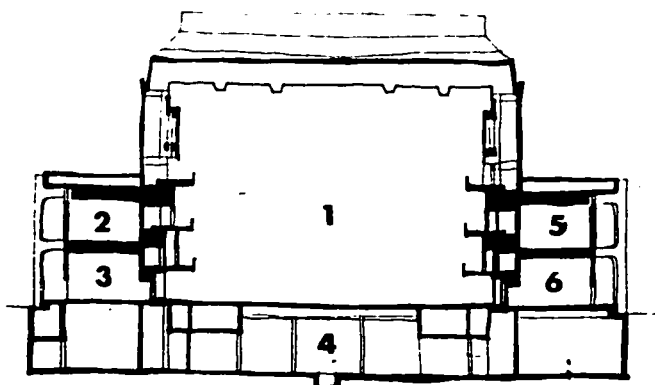

Fig. 16. Three Versions of the Grande Salle, Place des Arts, Montreal.



**PLACE DES ARTS**

*Opposite: detail of exterior wall treatment at foyer entrance. Some of the 8,000 elements comprising Norman Slater's aluminum wall can be seen.*



**PLAZA LEVEL PLAN (TOP LEFT):** 1 entrance foyer. 2 side lounge. 3 side lounge. 4 coal room lobby. 5 orchestra floor. 6 orchestra pit. 7 stage. 8 green room. 9 changing area. 10 side stage. 11 loading dock. 12 stage entrance.

**LOGE LEVEL PLAN (UPPER RIGHT):** 1 upper part piano mobile. 2 side lounge. 3 side lounge. 4 balcony. 5 box seats. 6 box seats. 7 stage house. 8 upper main rehearsal room. 9 rehearsal rooms. 10 administration.

**LONGITUDINAL SECTION (CENTRE):** 1 entrance foyer. 2 piano mobile. 3 theatre hall. 4 stage house. 5 elevator machine room. 6 rehearsal room. 7 male changing room. 8 female changing room. 9 boiler room.

**CROSS SECTION LOOKING NORTH (LEFT):** 1 hall interior. 2 side lounge. 3 side lounge-orchestra floor. 4 fan room. 5 side lounge. 6 side lounge-orchestra floor.

**Fig. 17. Plans and Sections. Grande Salle, Place des Arts, Montreal.**

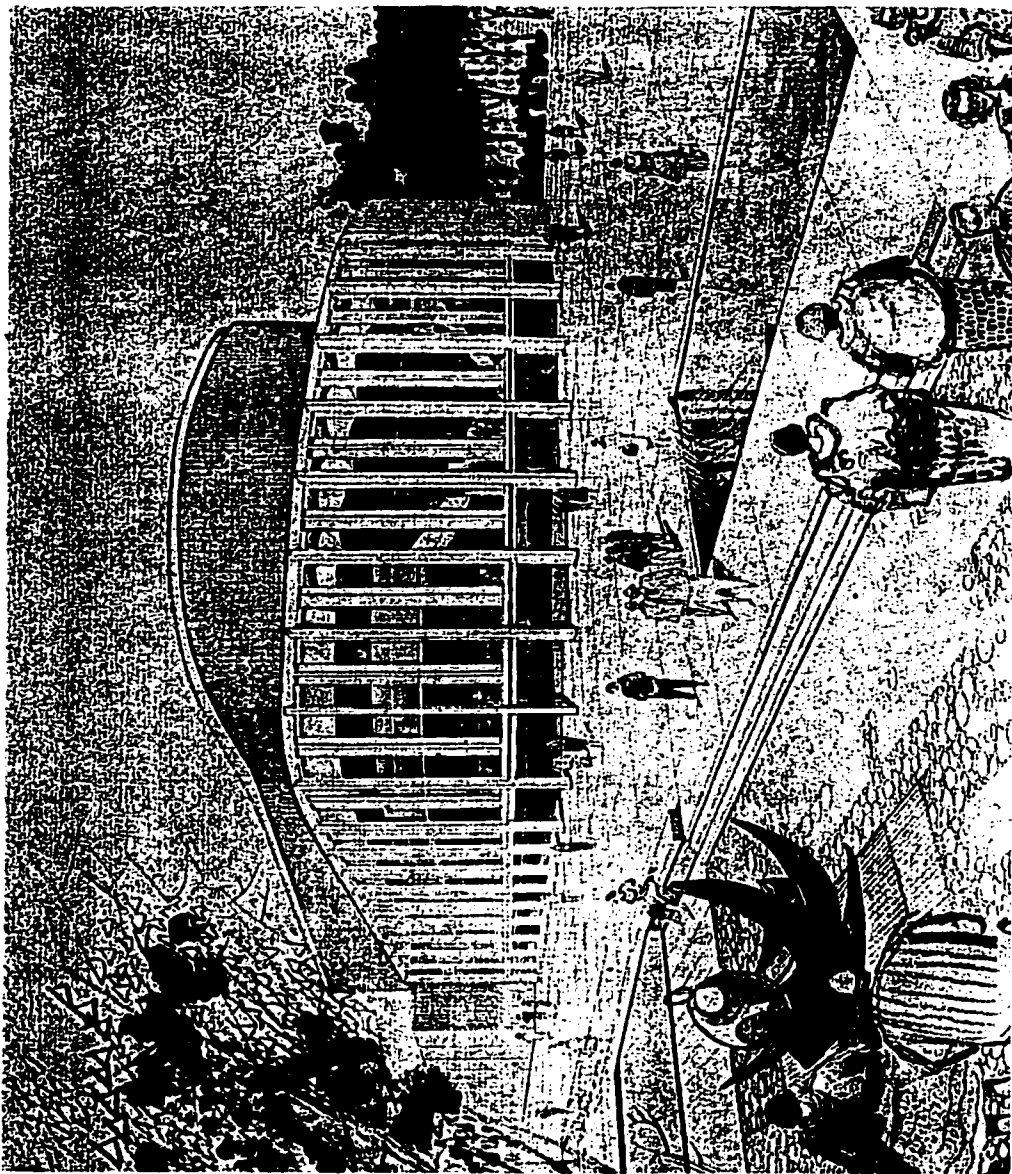

Fig. 18. Exterior Perspective. Grande Salle, Place des Arts, Montreal.



Fig. 19. Exterior View. Grande Salle, Place des Arts, Montreal, 1958-63.

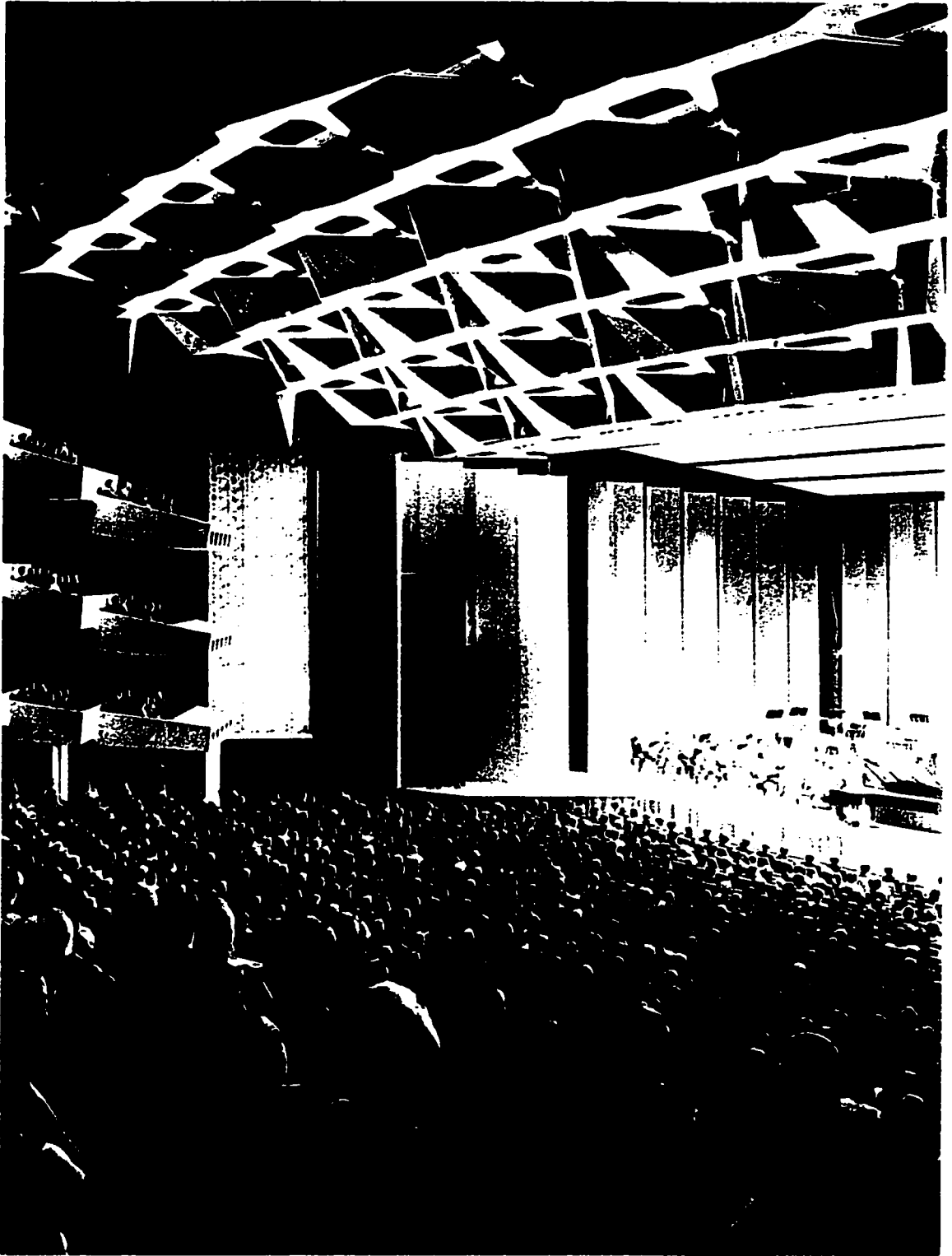

Fig. 20. Grande Salle Opening Night Audience on September 21, 1963.





Fig. 21. Affleck Desbarats Dimakopoulos Lebensold Sise in 1964.

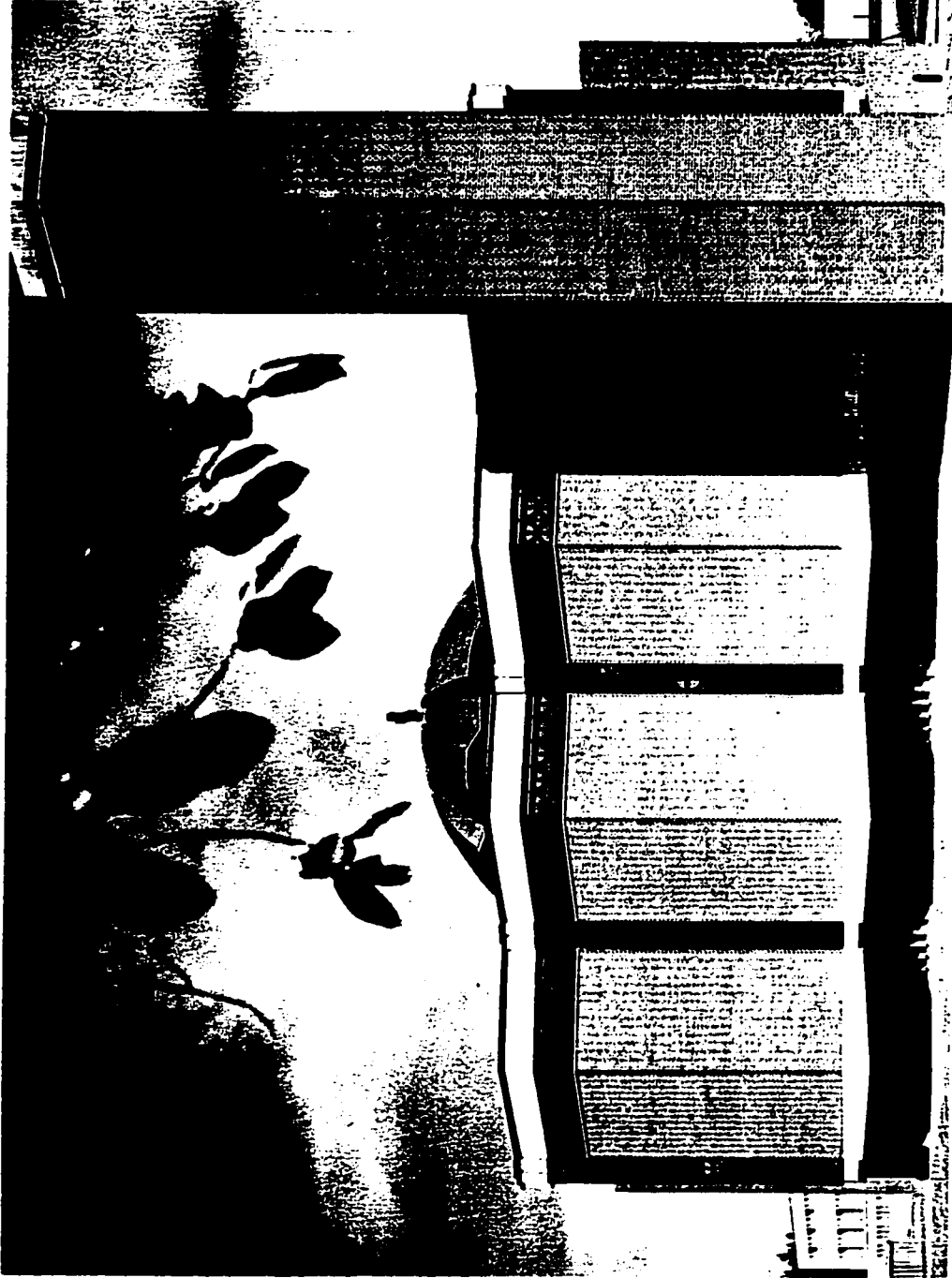
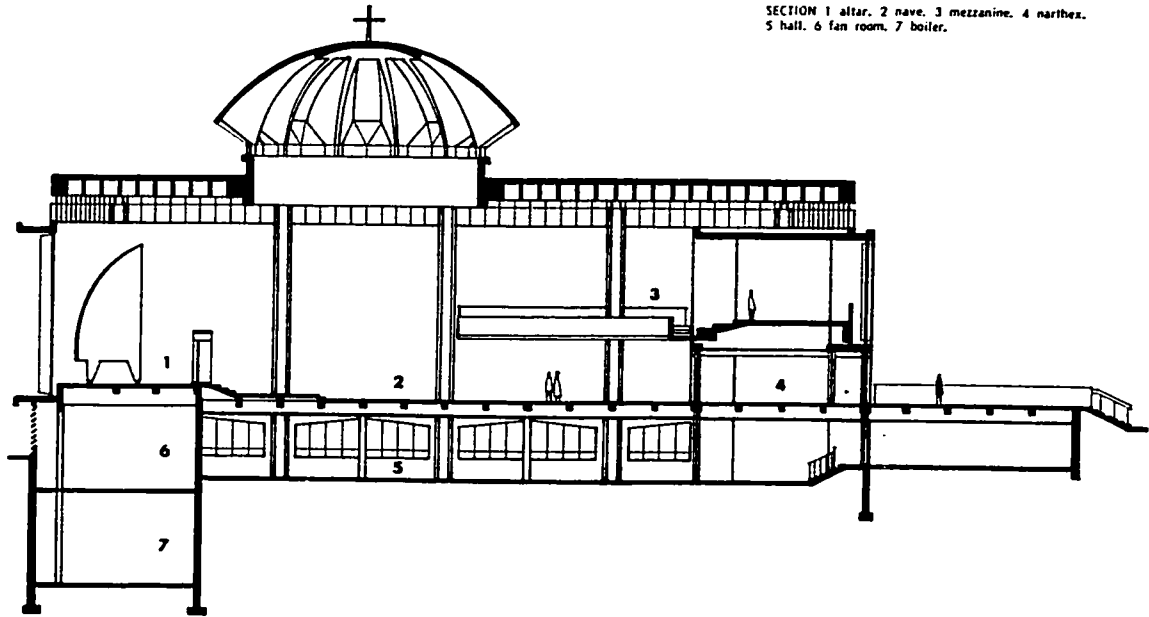
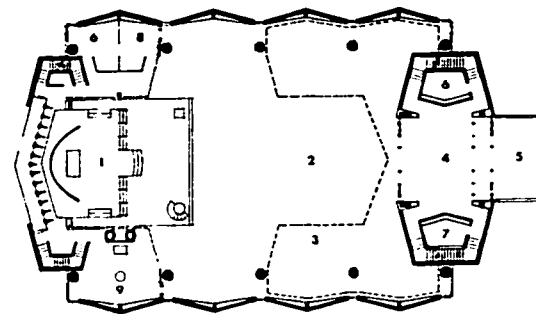
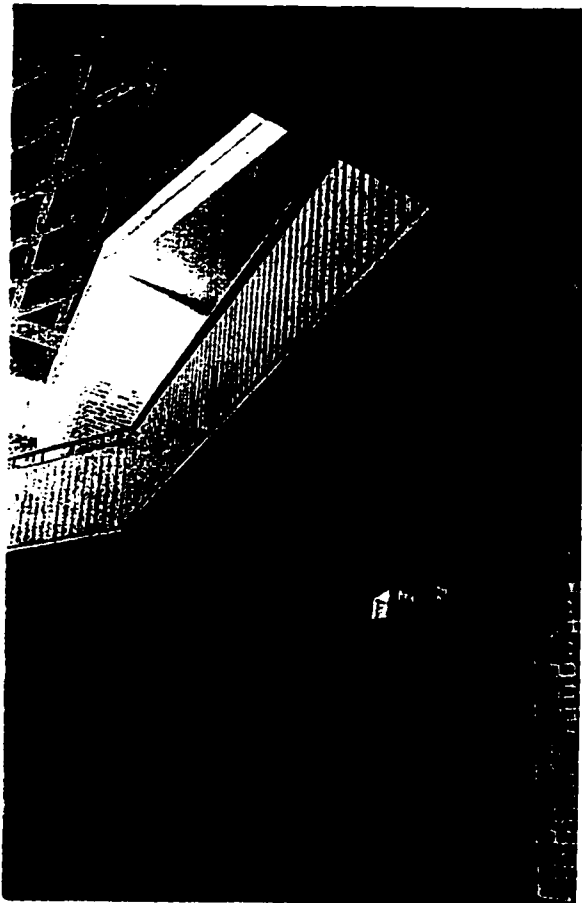

Fig. 22. St. George Greek Orthodox Cathedral, Montreal, 1958-62.



SECTION 1 altar, 2 nave, 3 mezzanine, 4 narthex, 5 hall, 6 fan room, 7 boiler.

GREEK ORTHODOX



LOWER FLOOR PLAN 1 fan room, 2 hall, 3 classroom, 4 lobby, 5 washroom.

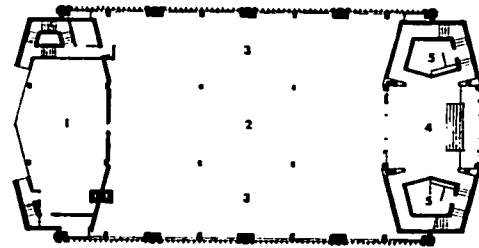

MAIN FLOOR PLAN 1 altar, 2 nave, 3 mezzanine above, 4 narthex, 5 bridge, 6 office, 7 waiting room, 8 confessional, 9 baptistry, 10 bell tower.

Left: the nave entry.

Fig. 23. Plans and Interior Detail. St. George Greek Orthodox Cathedral.

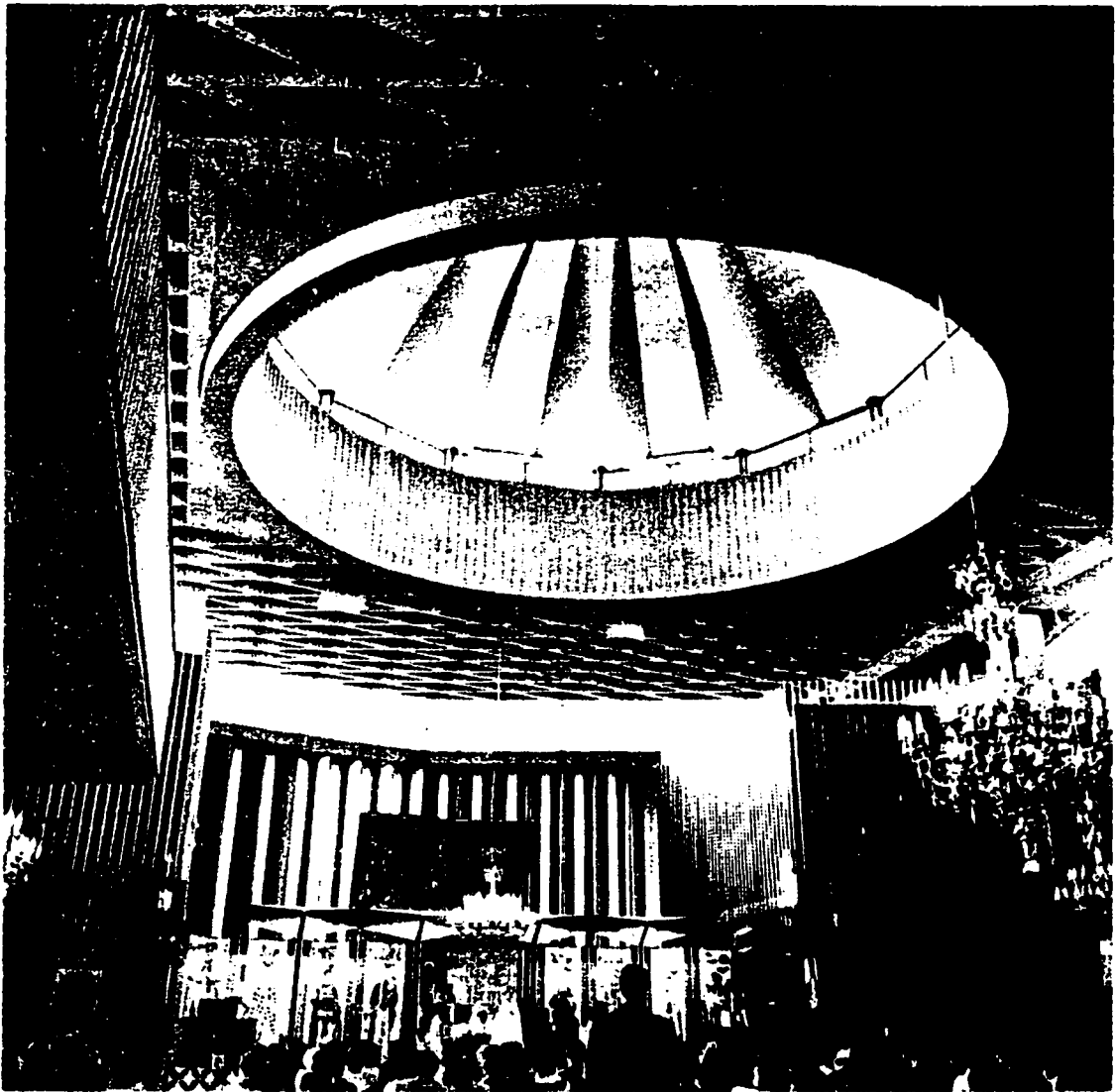

Fig. 24. Interior View. St. George Greek Orthodox Cathedral.

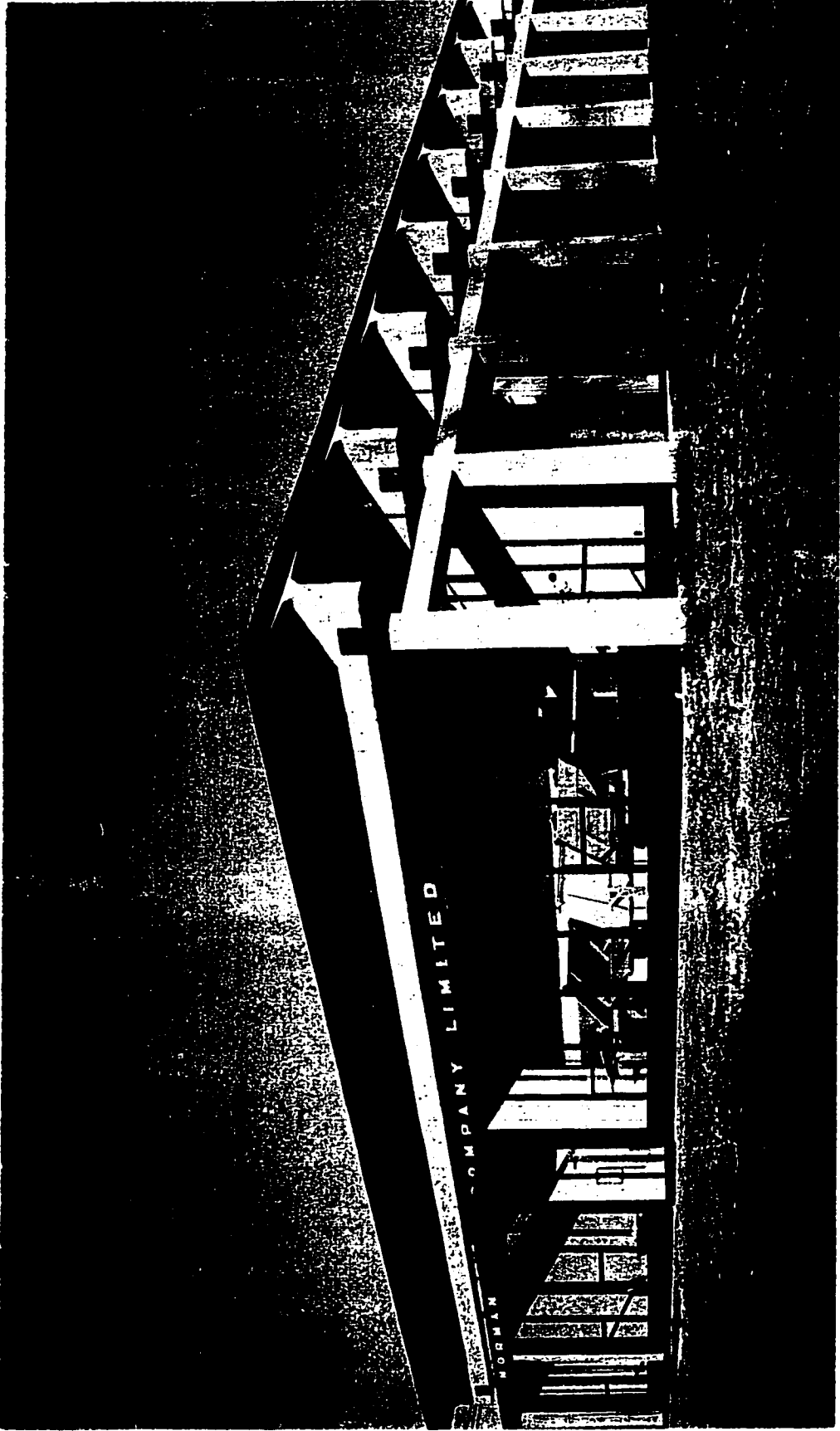

Fig. 25. Exterior View. Norman Wade Building, Pointe Claire, 1961-2.

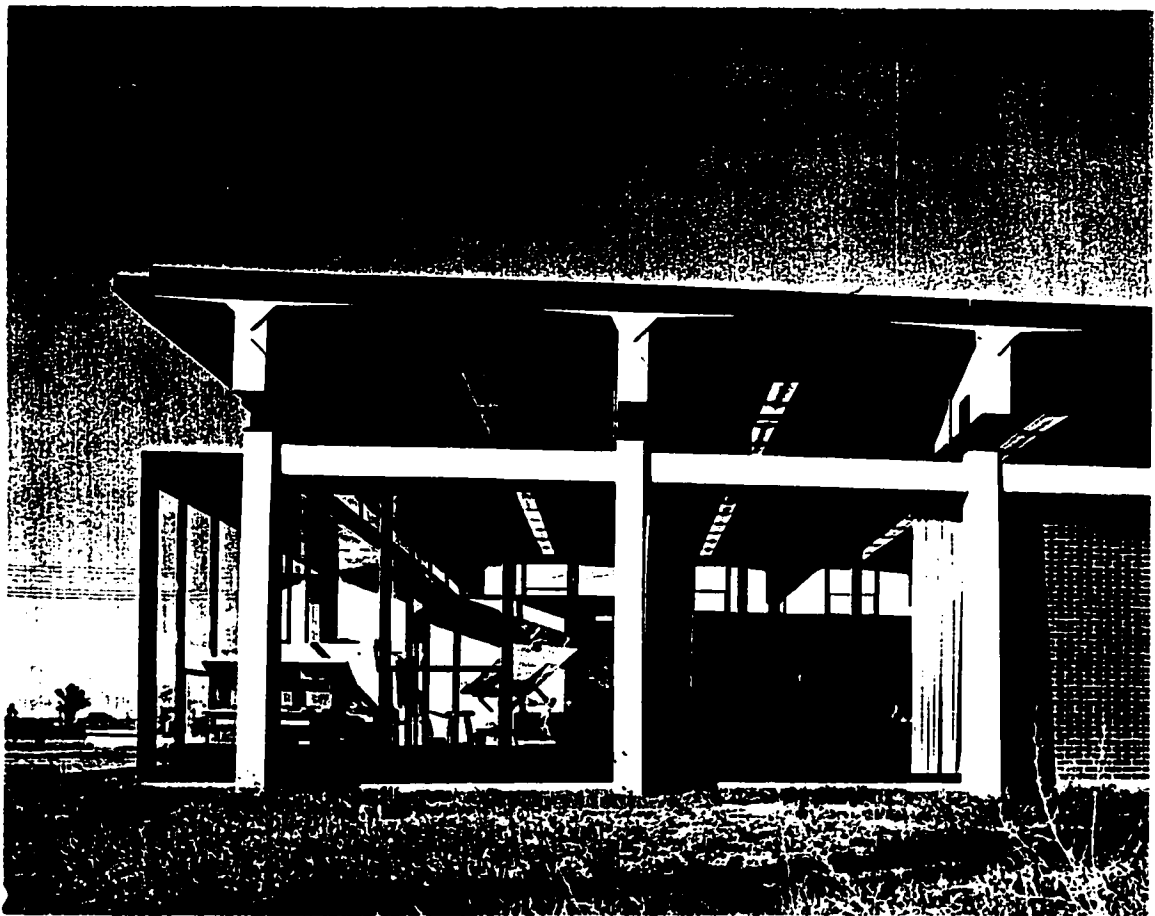
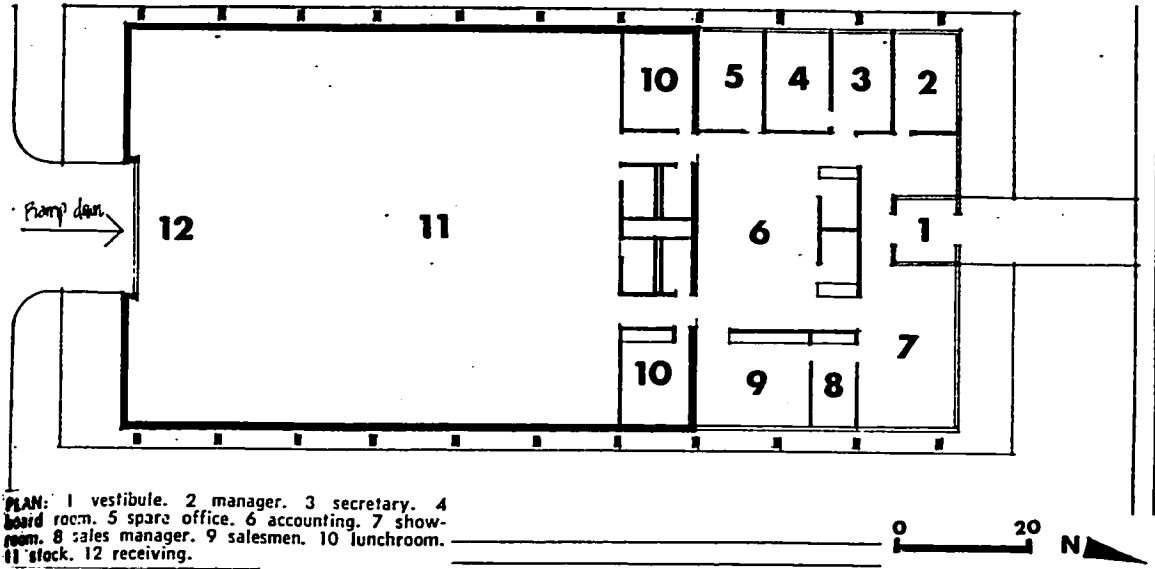
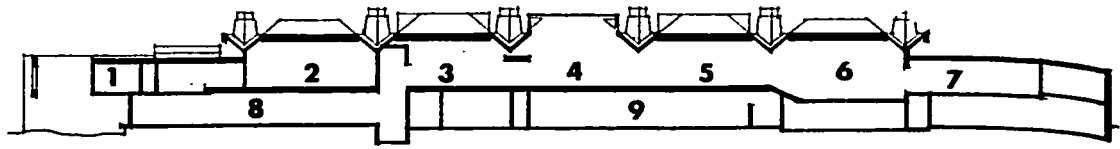

Fig. 26. Plan and Interior View. Norman Wade Building, Pointe Claire.



**SUMMERLEA GOLF  
& COUNTRY CLUB**

LONGITUDINAL SECTION (ABOVE): 1 bedroom, 2 men's bar and grill, 3 kitchen, 4 dining, 5 lounge, 6 lobby, 7 general office, 8 service room, 9 women's locker room.

UPPER LEVEL PLAN: 1 entry lobby, 2 upper part proshop, 3 living quarters, 4 lounge, 5 mixed

grill, 6 dining room, 7 cocktail lounge, 8 kitchen, 9 private dining, 10 men's bar and grill, 11 mechanical equipment, 12 staff quarters.

LOWER LEVEL PLAN: 1 entry lobby, 2 proshop display, 3 mustering entrance, 4 bag storage, 5 men's locker room, 6 women's locker room, 7 mechanical, 8 receiving service yard, 9 staff.

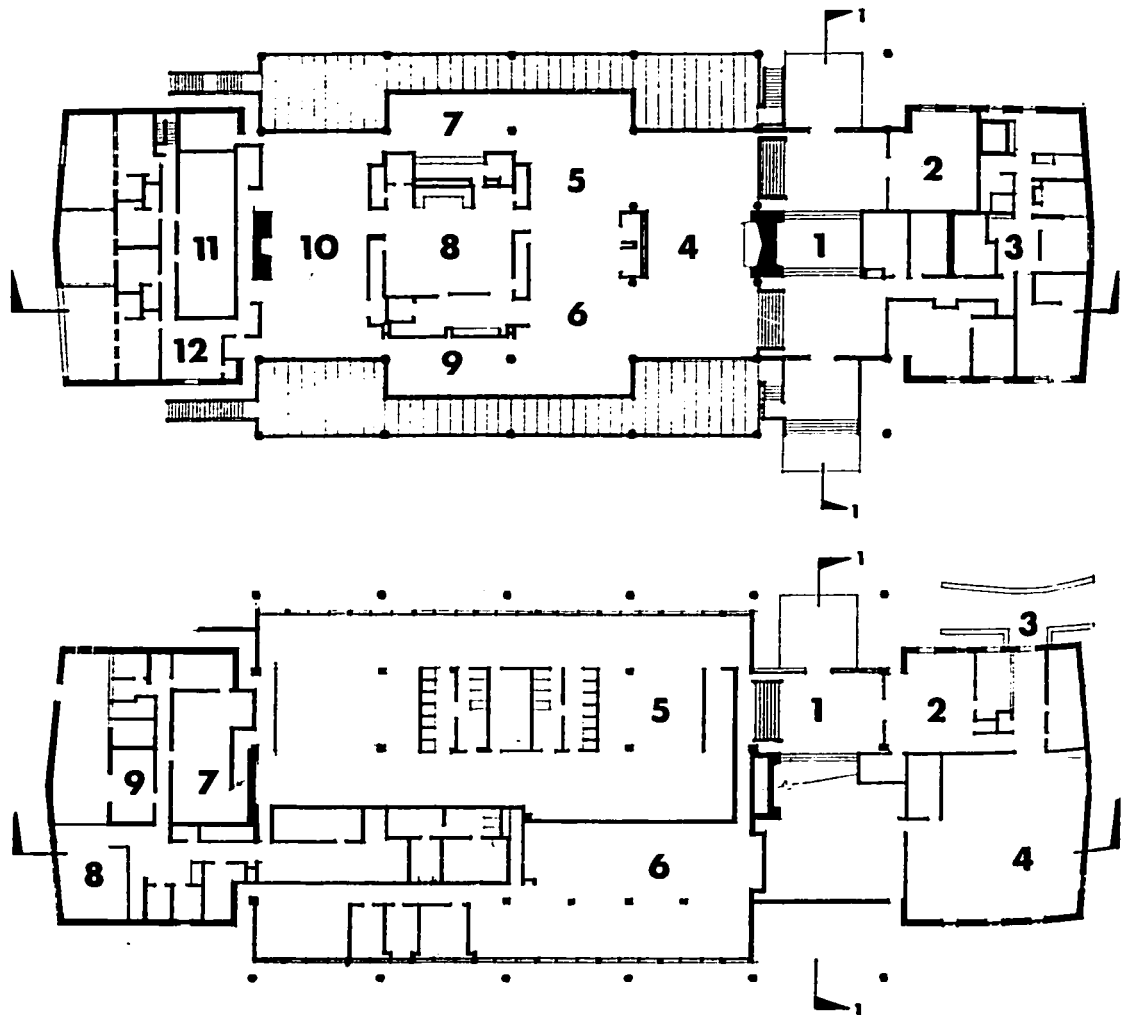
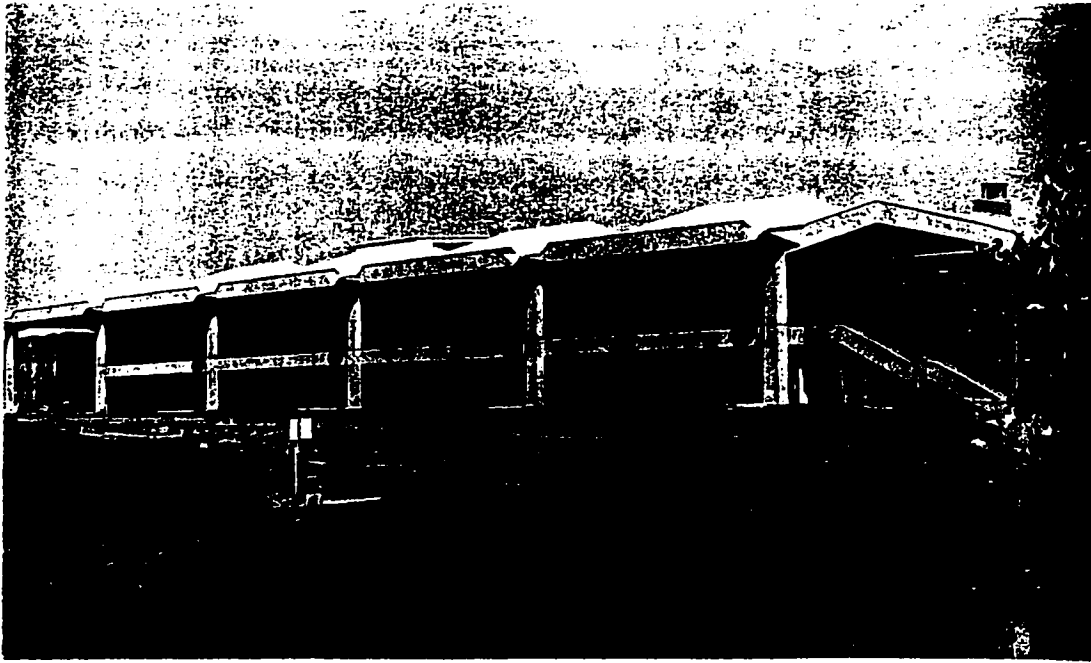
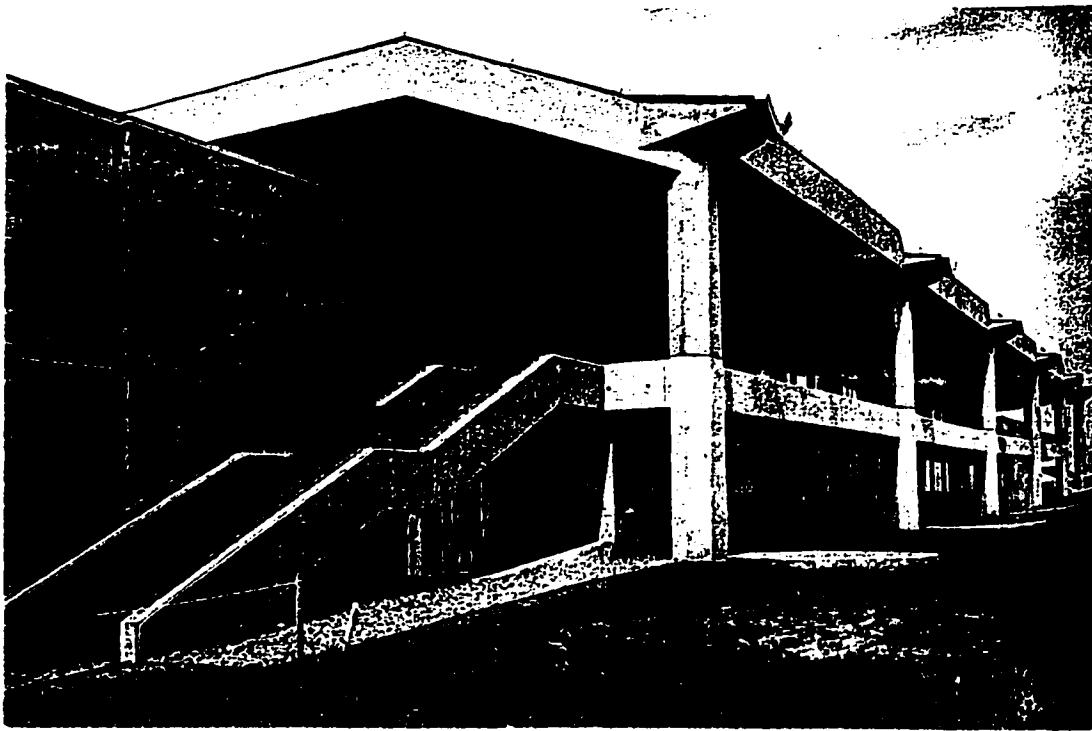

Fig. 27. Section and Plans. Summerlea Golf & Country Club, 1960-3.



**SUMMERLEA GOLF  
& COUNTRY CLUB**

*Above, bottom and opposite page:  
various views of the club illustrating  
how the exposed concrete, stone  
and the projecting water drips  
with their small stone bottoms work.*



**Fig. 28. Summerlea Golf & Country Club, Pointe Cascades, PQ, 1960-3.**



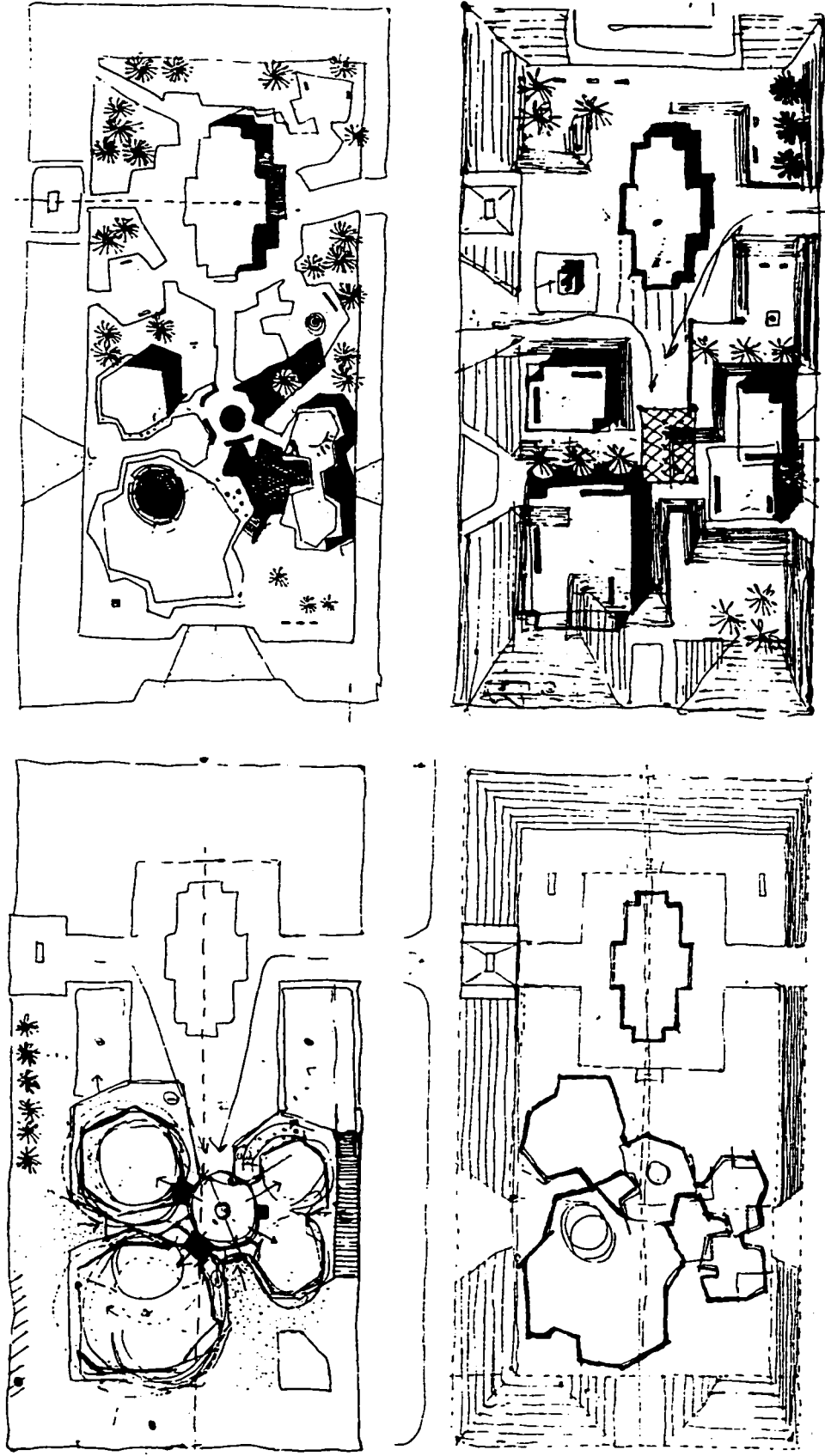
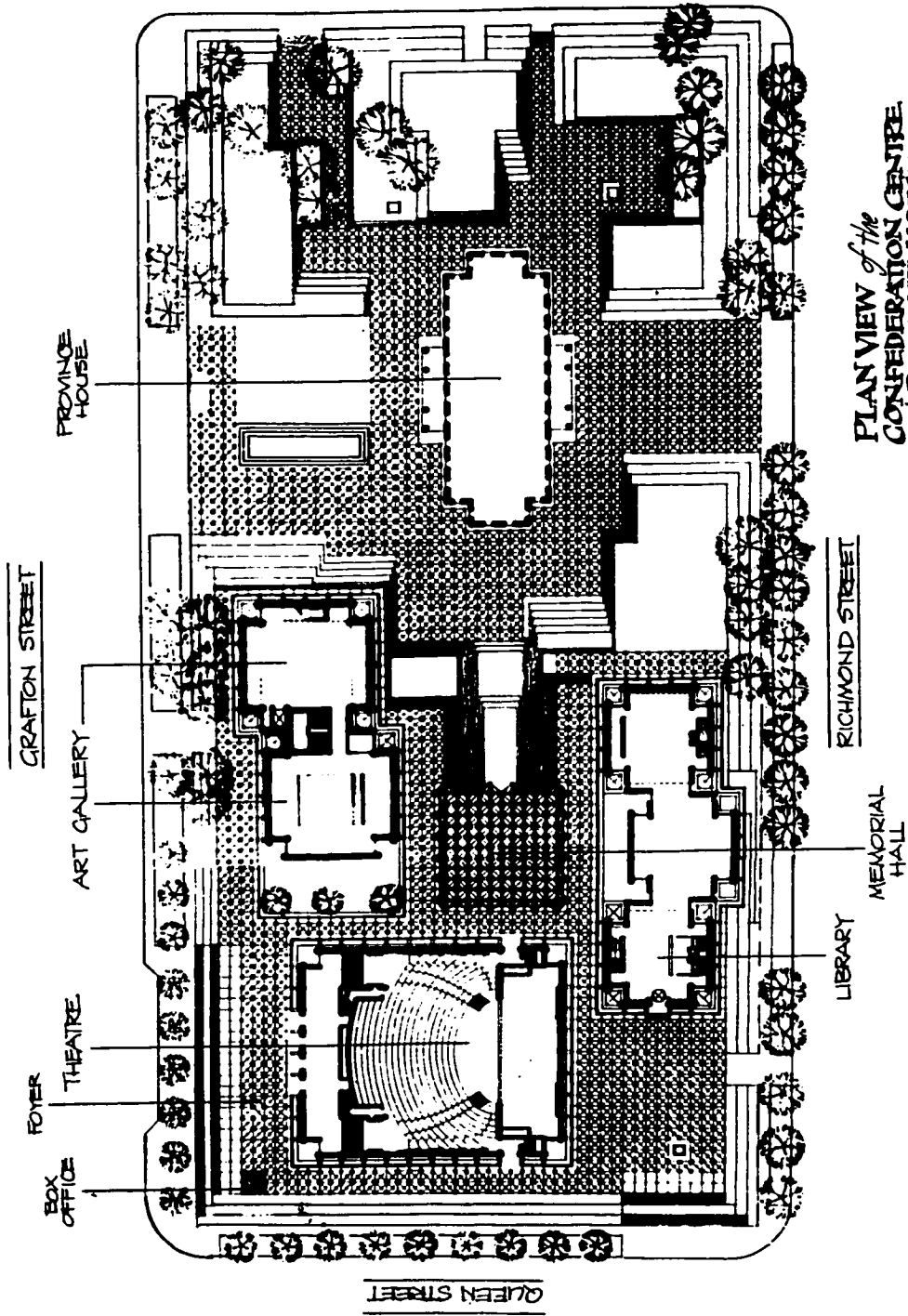
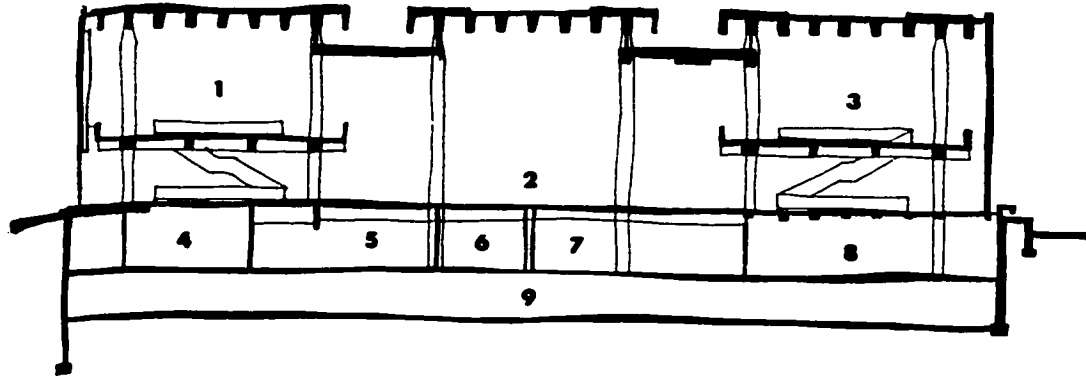

Fig. 29. Four Site Plans. Progressive Design Sketches. Fathers of Confederation Memorial Building Competition Project for Charlottetown, 1962.



PLAN VIEW of the  
CONFEDERATION CENTRE  
and PROVINCE HOUSE.

Fig. 30. Plan View. Fathers of Confederation Memorial Building Competition Project for Charlottetown, 1962.



LIBRARY SECTION: 1 open stack area. 2 main reading room. 3 legislative library. 4 working area. 5 chief librarian. 6 board room. 7 reception. 8 children's library. 9 stacks.

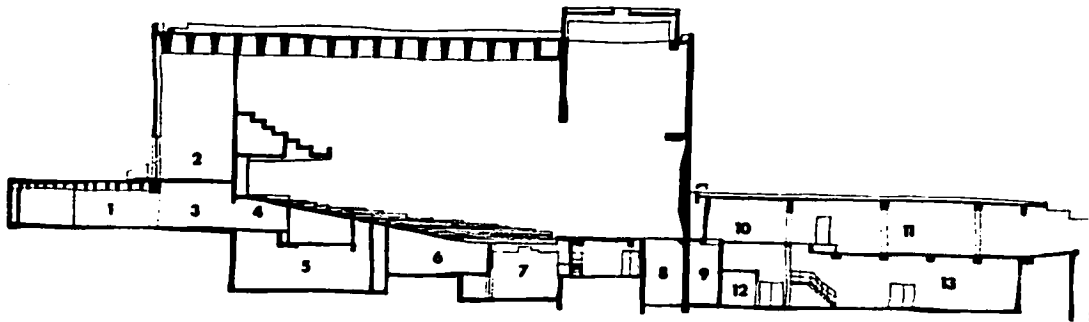

THEATRE SECTION: 1 concourse. 2 upper foyer. 3 lower foyer. 4 coat room. 5 mechanical. 6 orchestra storage area. 7 orchestra pit. 8 organ elevator pit. 9 paint slot. 10 workshop area. 11 service court. 12 office. 13 boiler.

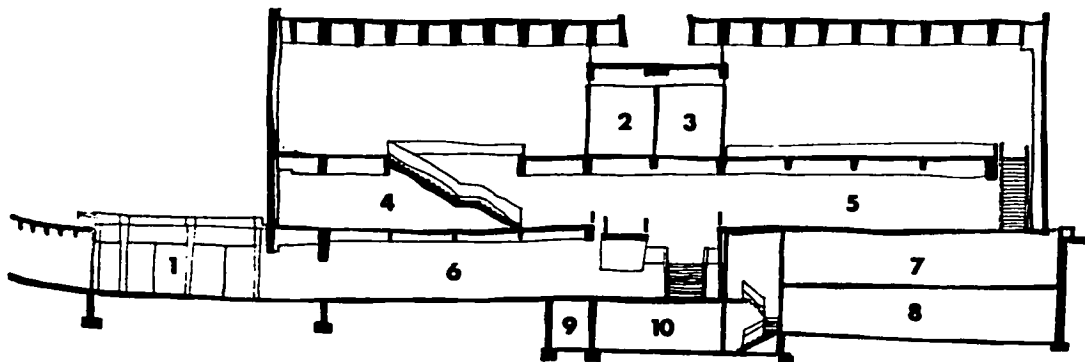

ART GALLERY & MUSEUM SECTION: 1 sculptural court. 2 board room. 3 curator. 4 exhibition. 5 exhibition. 6 lecture room. 7 archives. 8 storage. 9 mechanical equipment tunnel. 10 reserve collection.

Fig. 31. Sections. Fathers of Confederation Memorial Building  
Competition Project for Charlottetown, 1962.

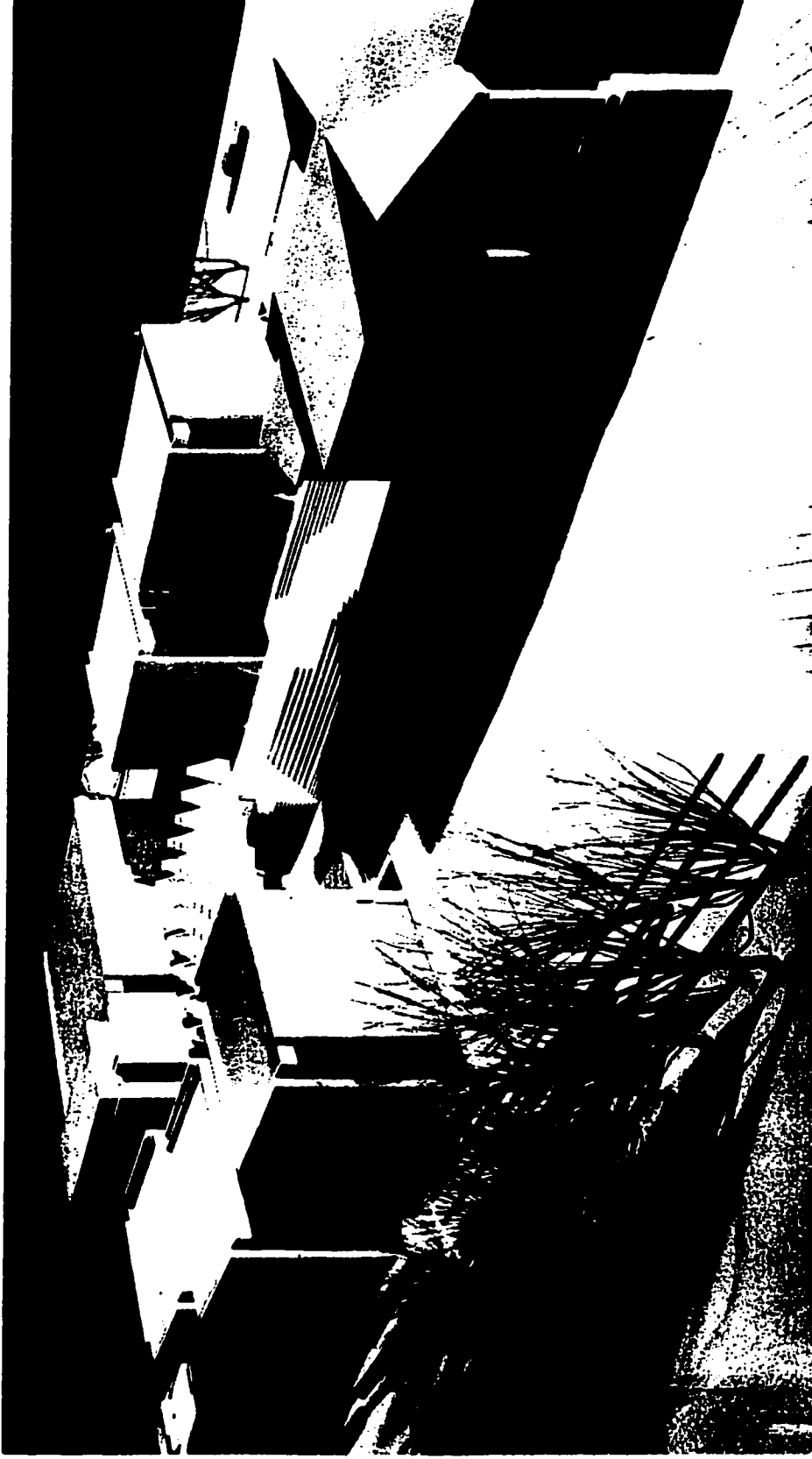

Fig. 32. Competition Model. Fathers of Confederation Memorial Building Competition Project for

Charlottetown, P.E.I., 1962.



**Fig. 33. Prime Minister John Diefenbaker and Winning Architect Dimitri Dimakopoulos with Memorial Building Model, Ottawa, 1962.**



Fig. 34. View on the Theatre from the West. Fathers of Confederation Memorial Building, Charlottetown, 1962-4.

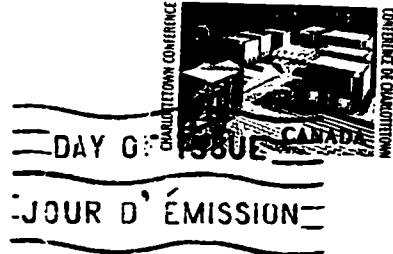

Confederation Chamber preserved as it was a century ago

Commemorating the 100<sup>th</sup> anniversary

# CHARLOTTETOWN CONFERENCE

where the first idea of confederation was discussed

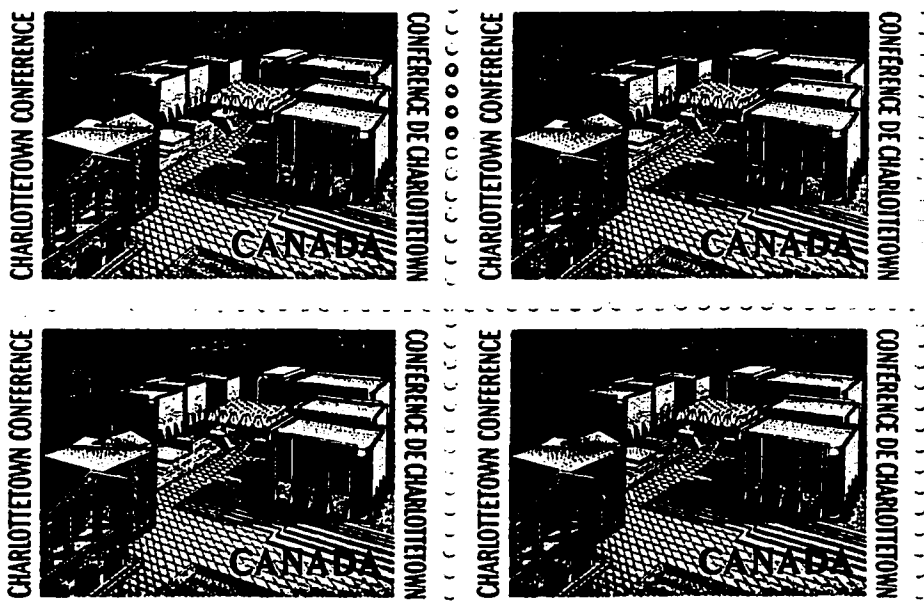

CANADIAN BANK NOTE CO., LIMITED.  
OTTAWA N91

Fig. 35. Stamp. First Day of Issue Commemorating the 100th Anniversary of the Charlottetown Conference, July 29, 1964.



Fig. 36. Her Majesty, Queen Elizabeth II Inaugurating the Fathers of Confederation Memorial Building on

October 6, 1964.

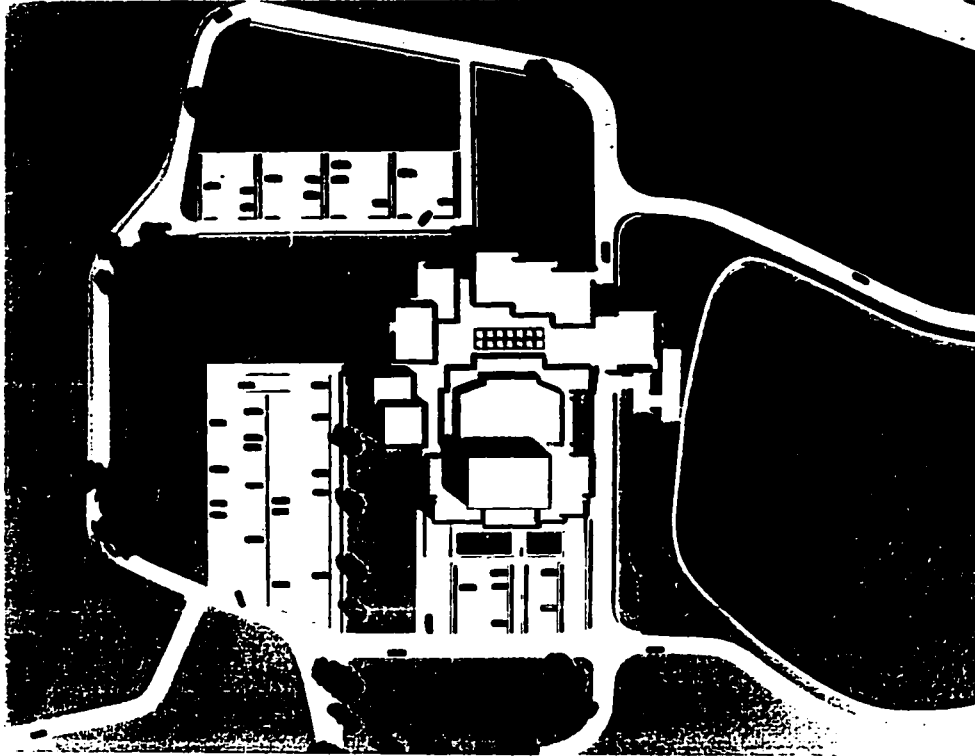



Fig. 37. View from the South-East. Provincial Government Centre, Charlottetown, P.E.I., 1963-5.



Fig. 38. South-East Corner Tower. Place Bonaventure, Montreal, 1963-7.



aspects de la maquette

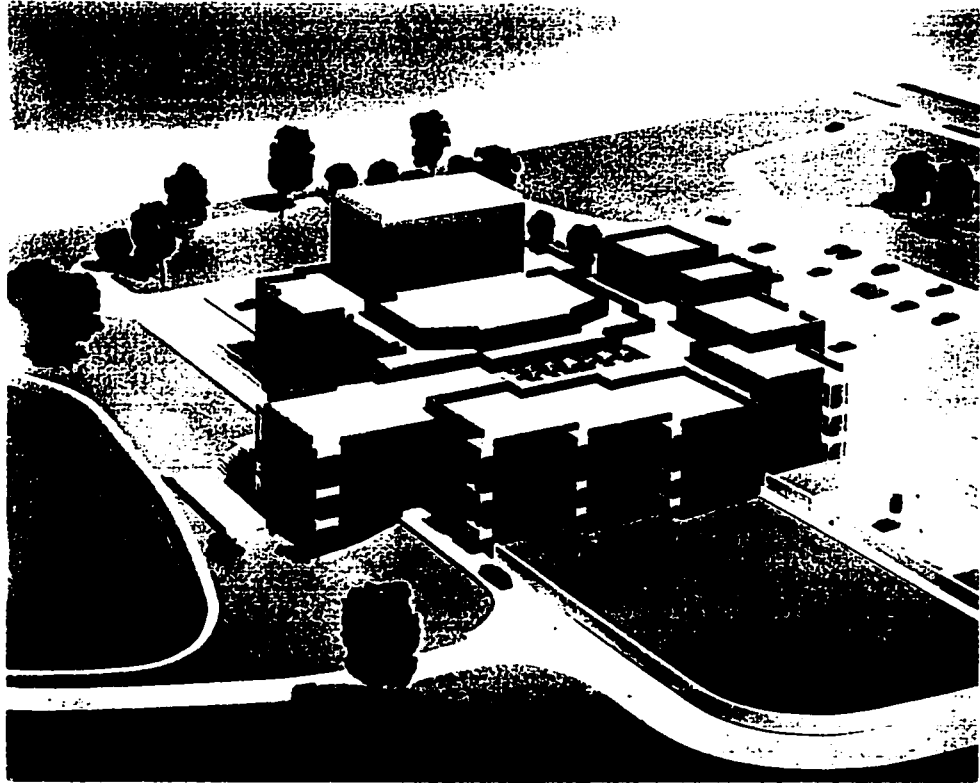

Fig. 39. Site Plan and Model. Arts and Cultural Centre, St. John's, 1964-7.

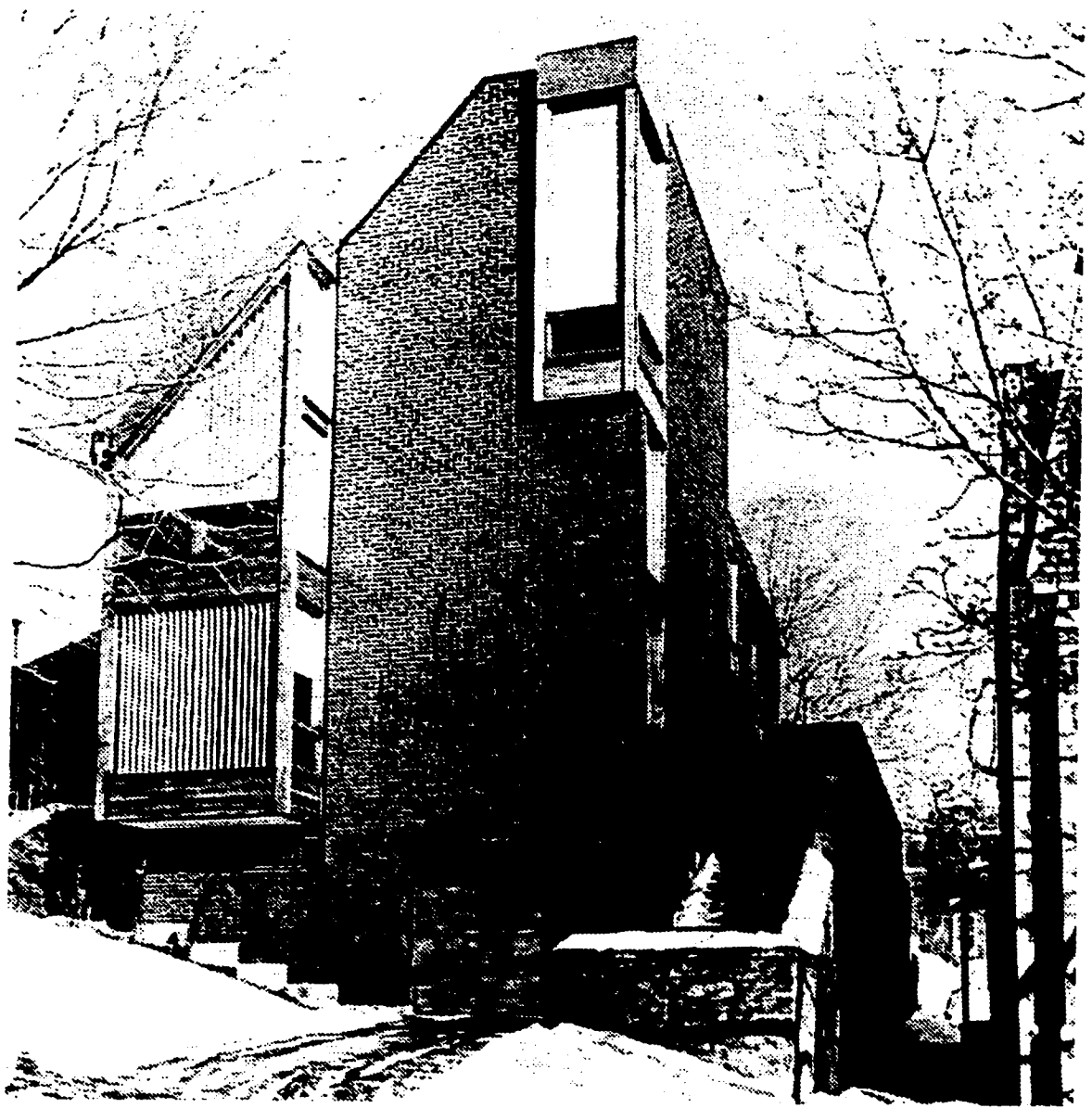

Fig. 40. Dimakopoulos Residence, 461 Clarke Ave., Westmount, 1966-7.

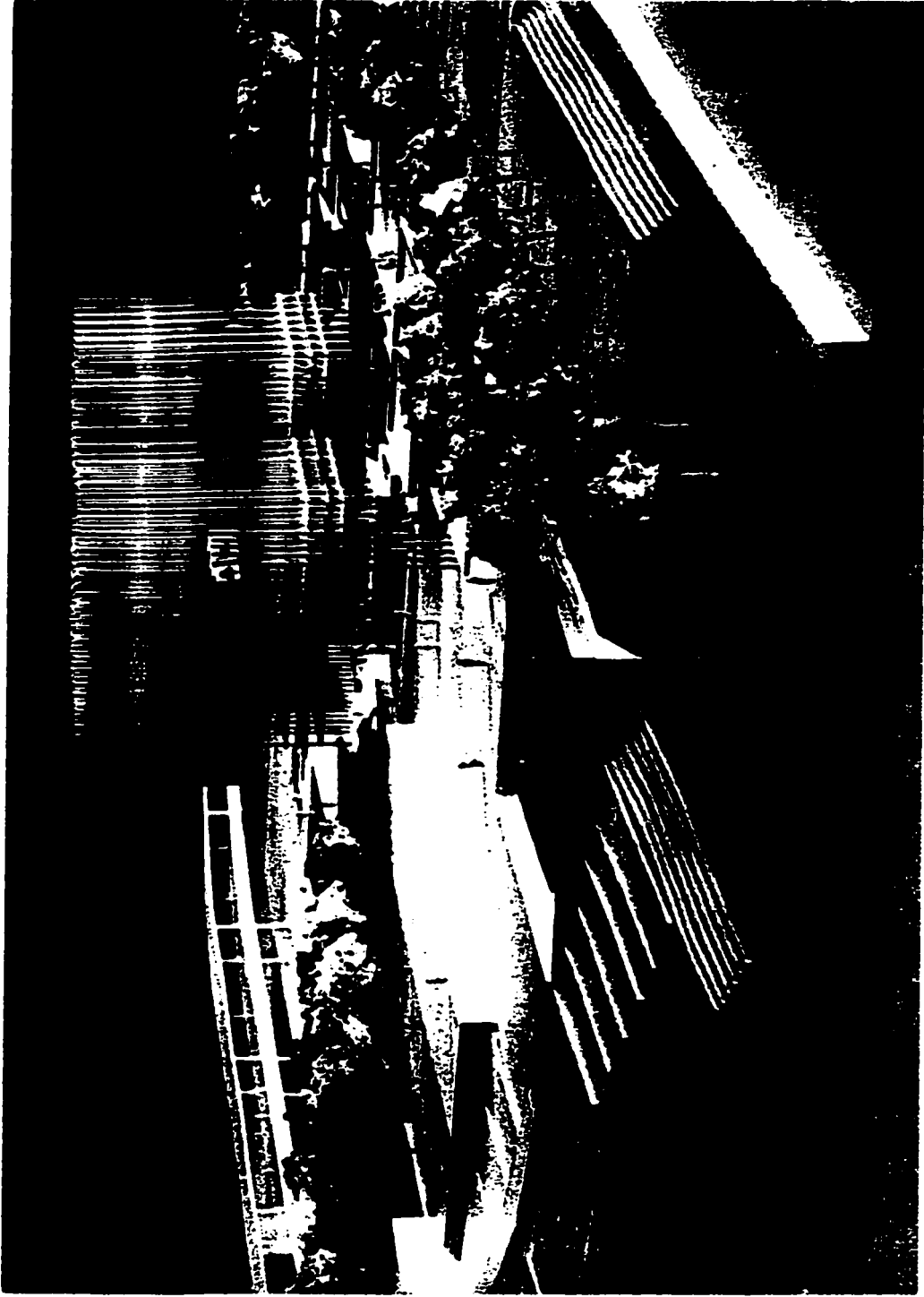

Fig. 41. Model. Osaka '70 Canadian Pavilion Competition Project, 1966-7.

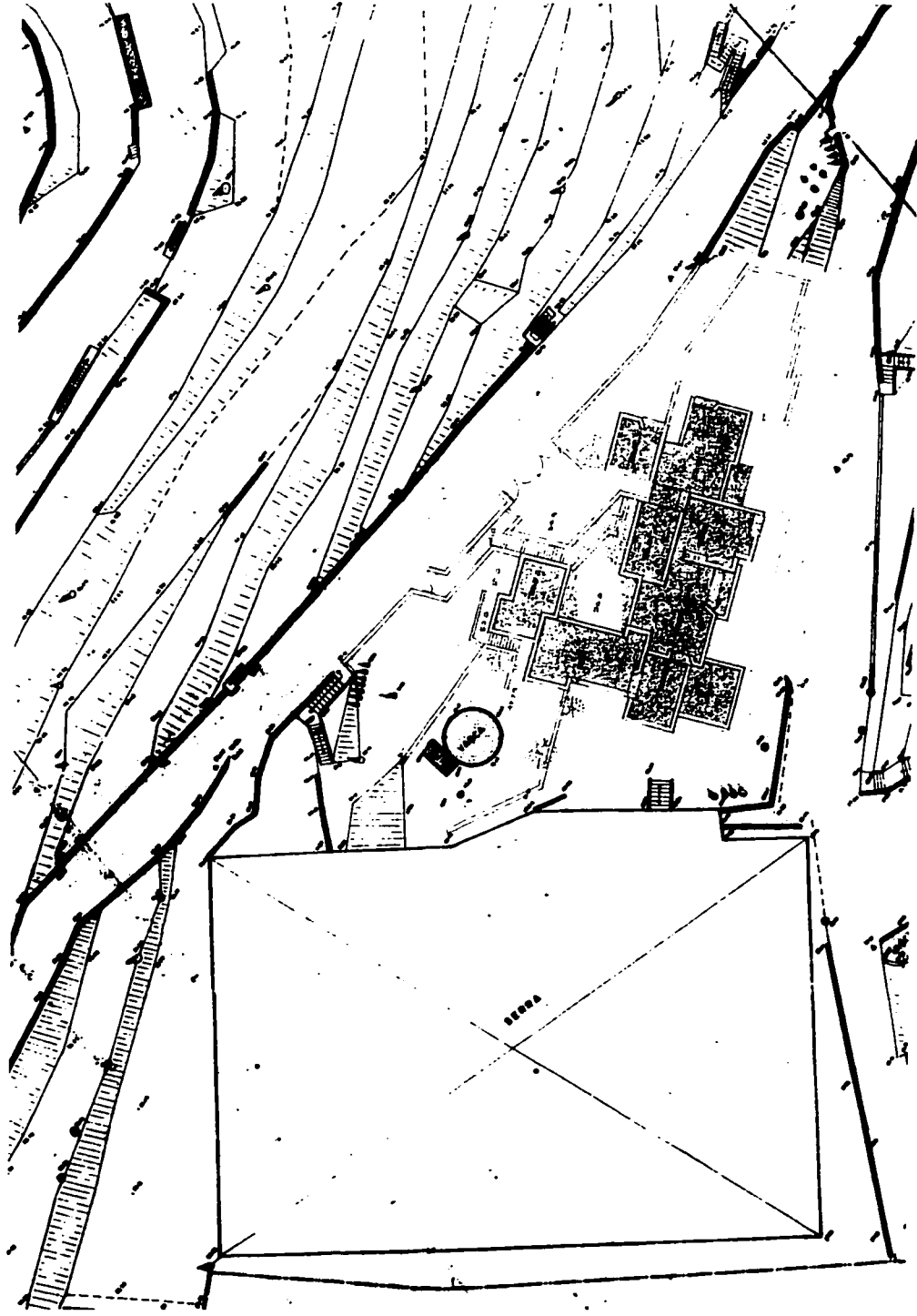

Fig. 42. Site Plan. Carlo Della Valle's Residence, Alassio, Italy, 1967-8.

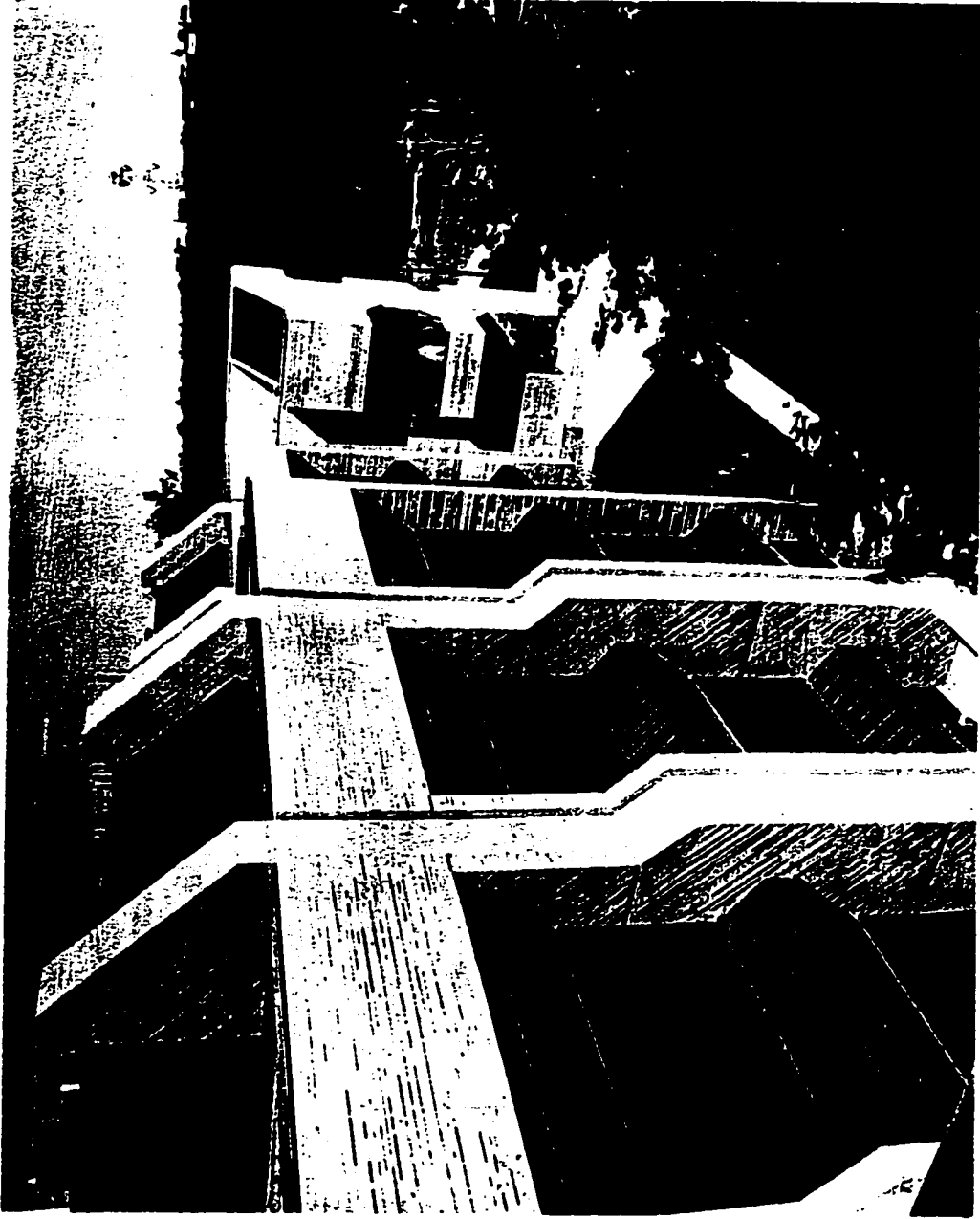
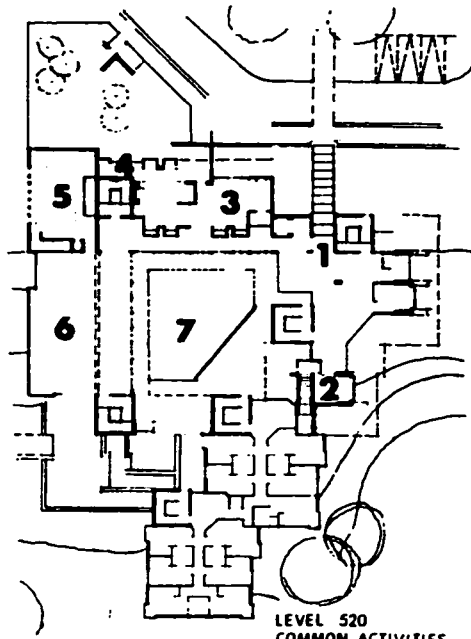
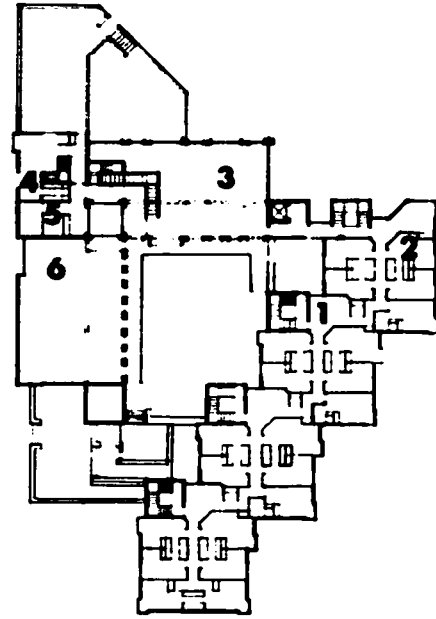

Fig. 43. View on Exterior Wall. Complexe Scientifique, Ste-Foy, 1968-9.



- LEVEL 520  
COMMON ACTIVITIES**
- 1 entry foyer
  - 2 exam room
  - 3 bar
  - 4 common room
  - 5 kitchen
  - 6 dining room
  - 7 court



- LEVEL 532 RESIDENCES**
- 1 lounge
  - 2 bedroom
  - 3 library
  - 4 director's quarters
  - 5 office
  - 6 upper part of dining hall

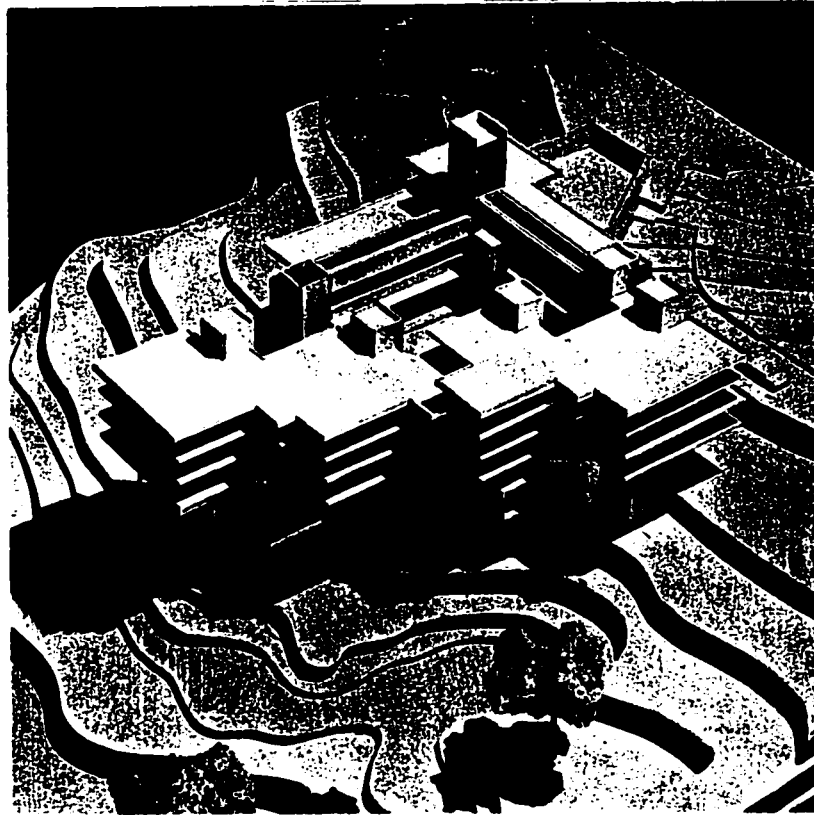

Fig. 44. Collège Montis Regii Project, Université de Montréal, 1969.





Fig. 45. Model. Cité Concordia Project, Montreal, 1969-73.



Fig.46. Model. Concordia West Block Project, Montreal, 1969-73.

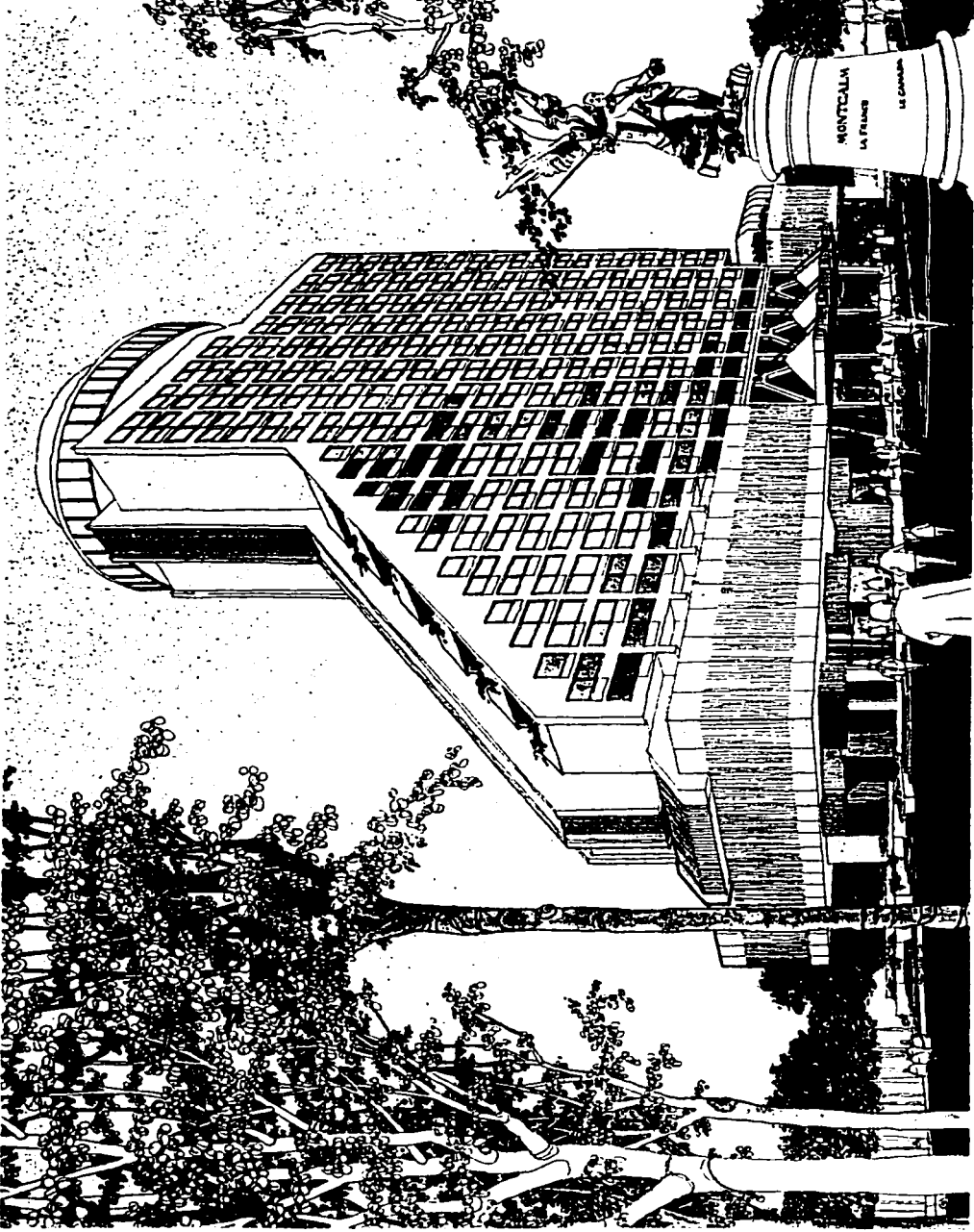

Fig. 47. Exterior Perspective. Hotel Loews Le Concorde, Quebec City, 1969-74.

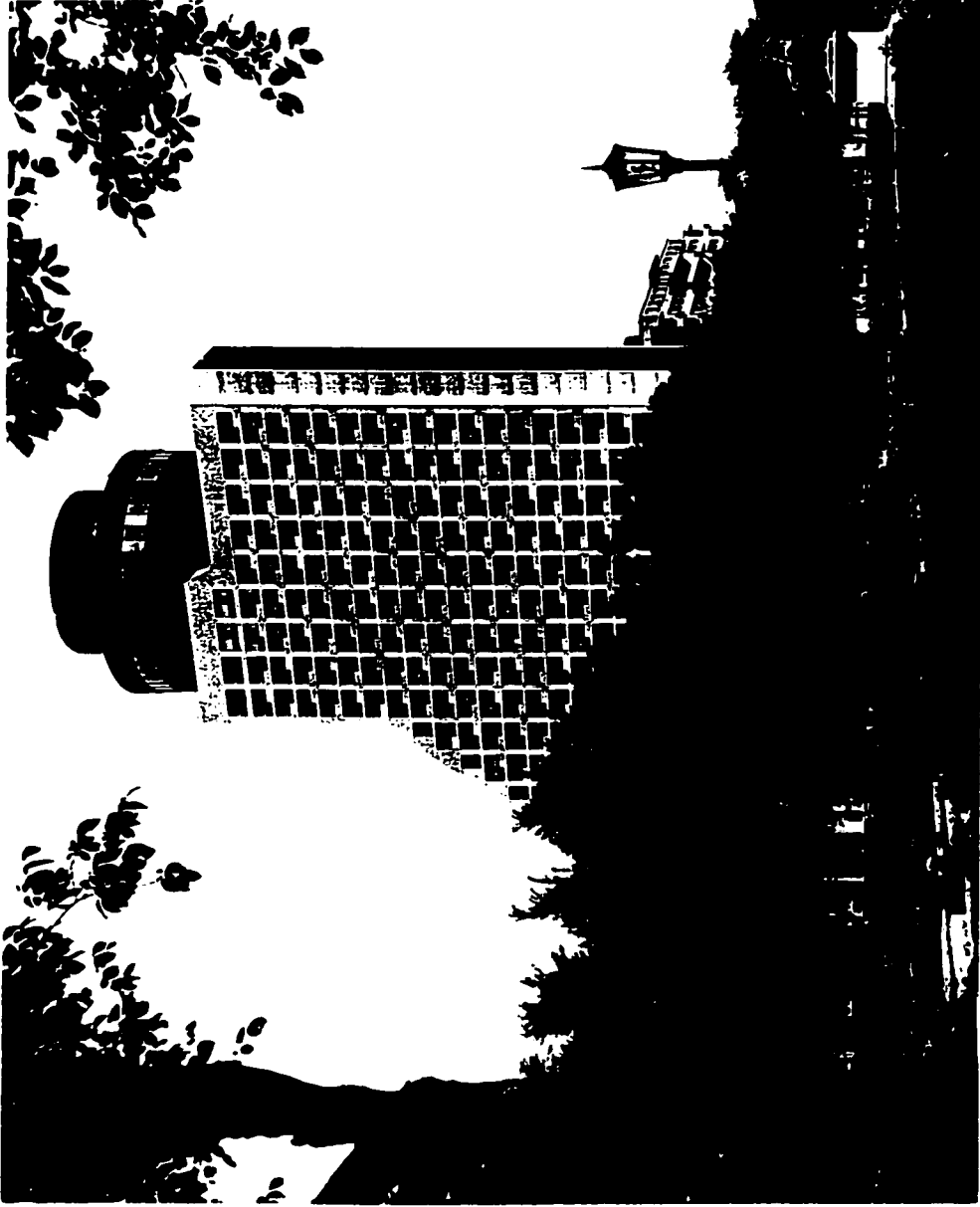

Fig. 48. View from Place Montcalm. Hotel Loews le Concorde, Quebec City.

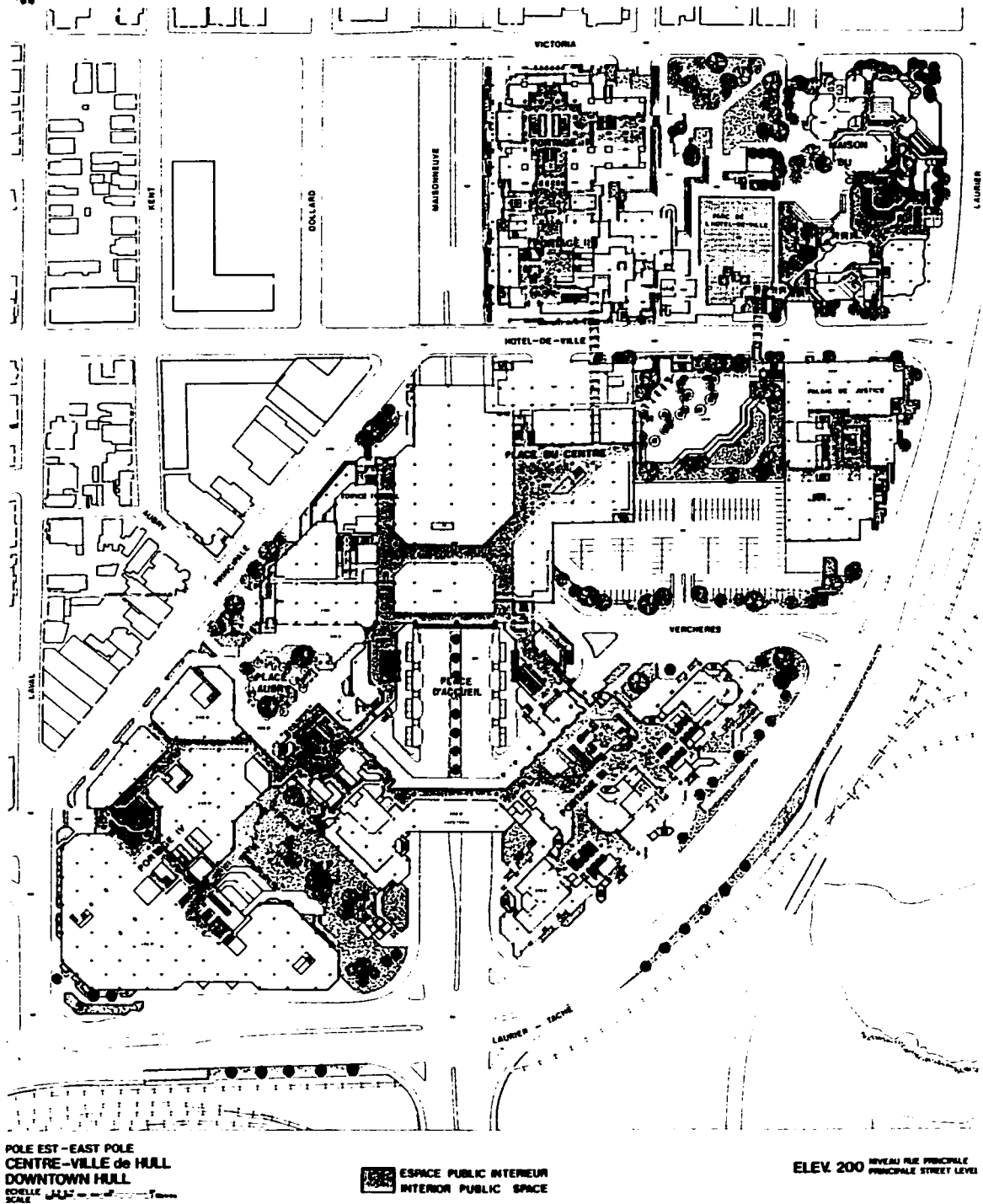

Fig. 49. Interior Public Space. Elev. 200. Site Plan. East Pole, Hull, c.1974.

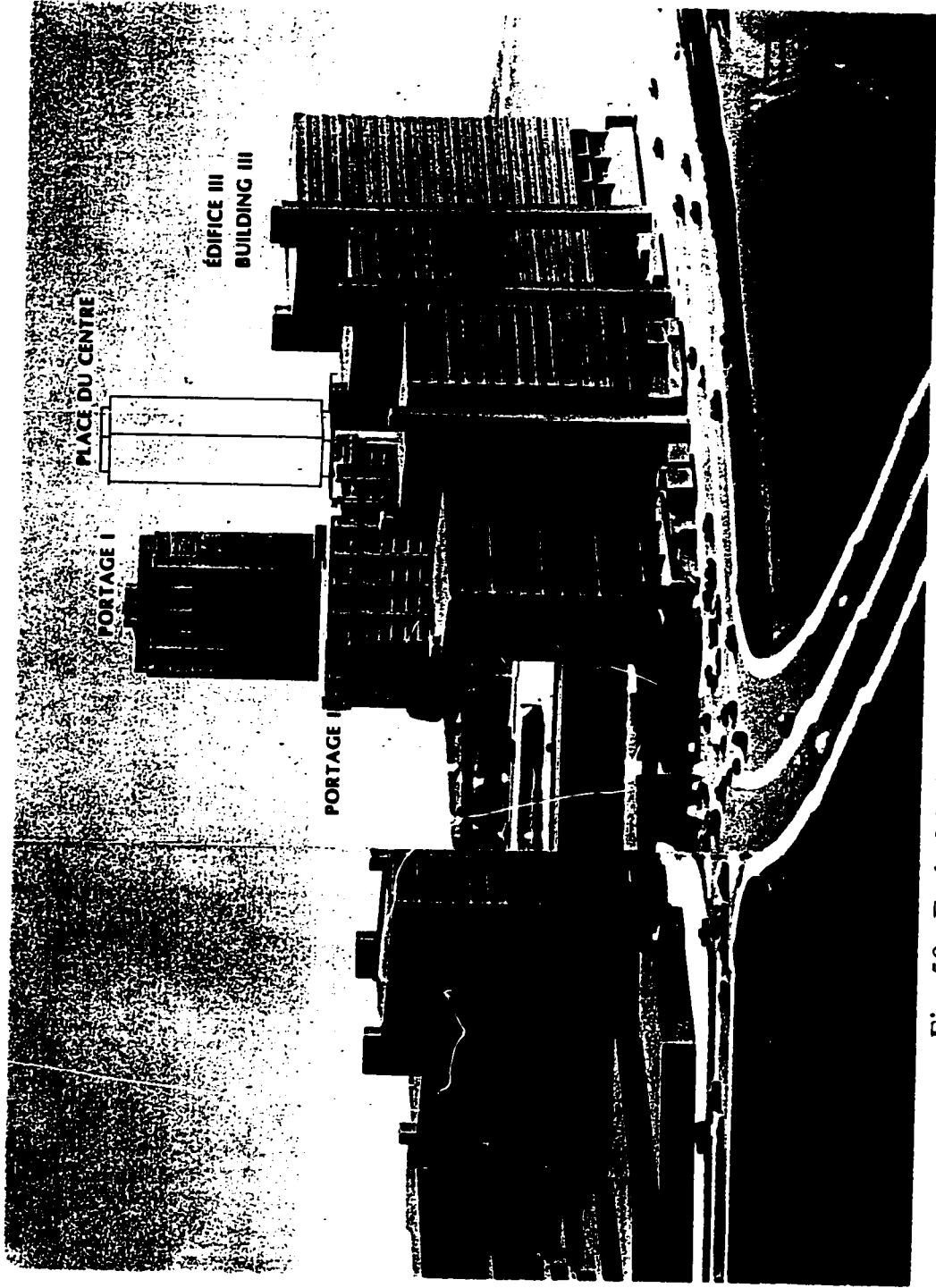

Fig. 50. Early Model. East Pole. Downtown Hull, c.1972.

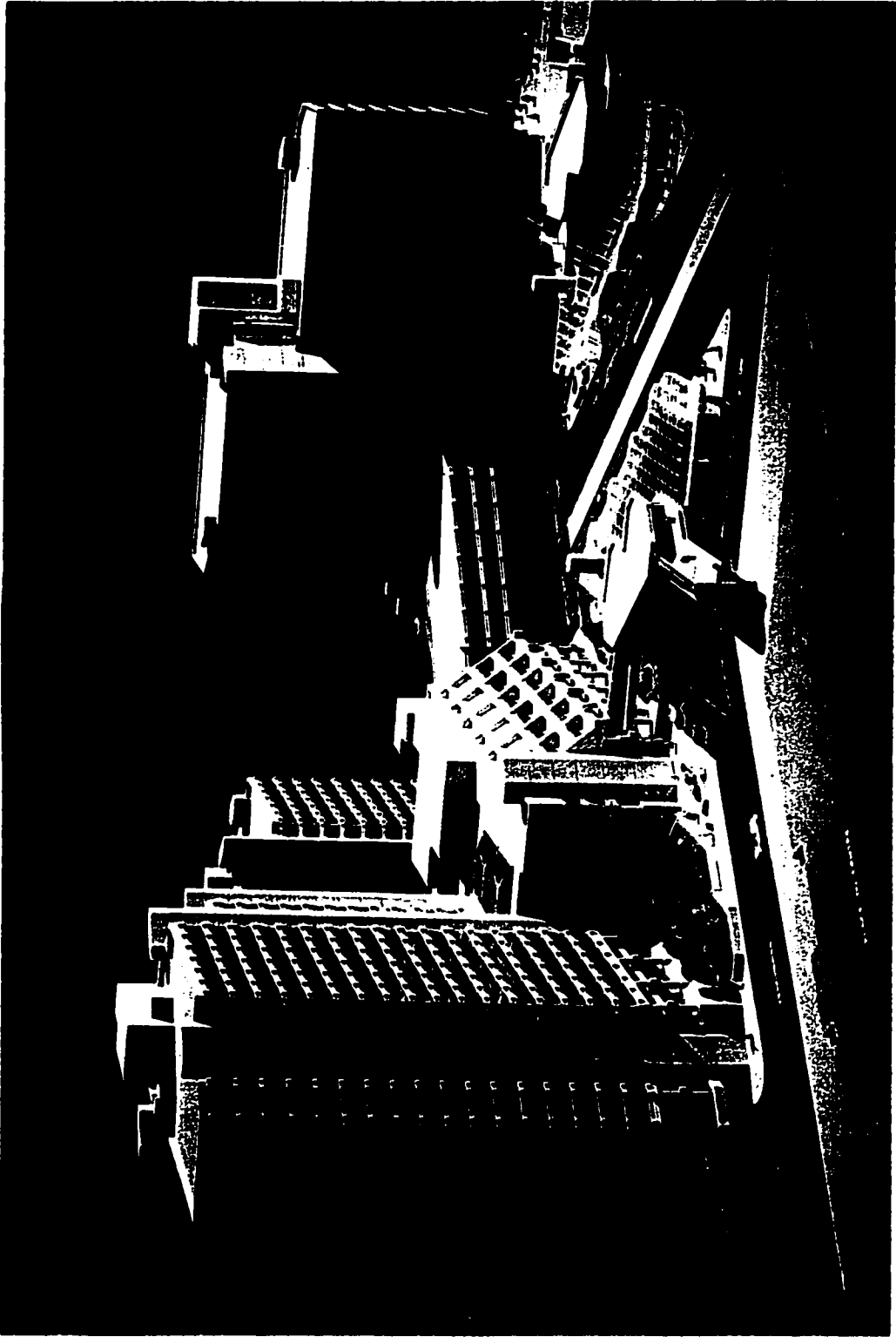

Fig. 51. Late Model. Place d'Accueil and Place du Portage III, Hull, c.1973.

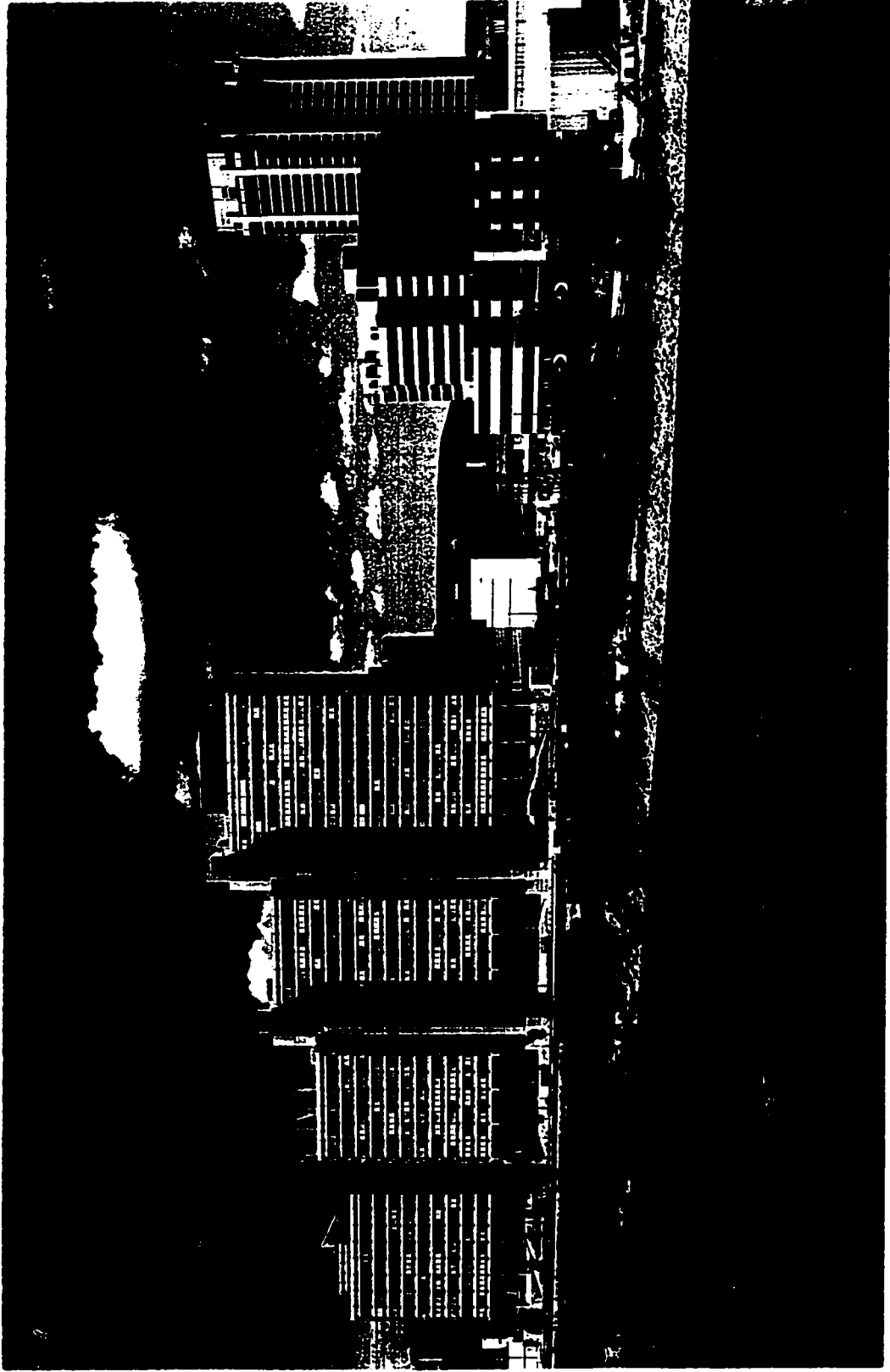

Fig. 52. Place du Portage III and Place du Centre, Hull, 1977.



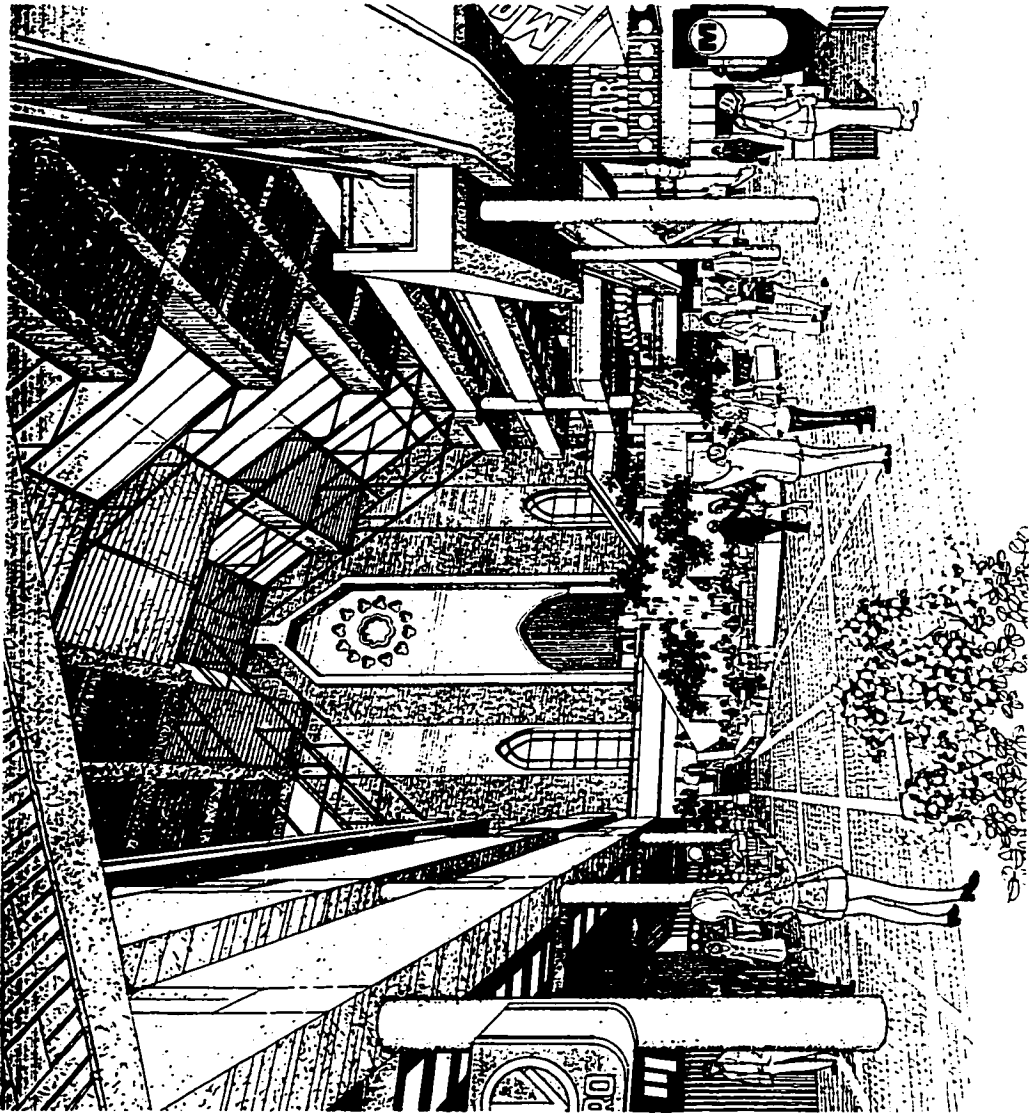

Fig. 53. Interior Perspective of Atrium, UQAM Phase I, Montreal, 1971-9.

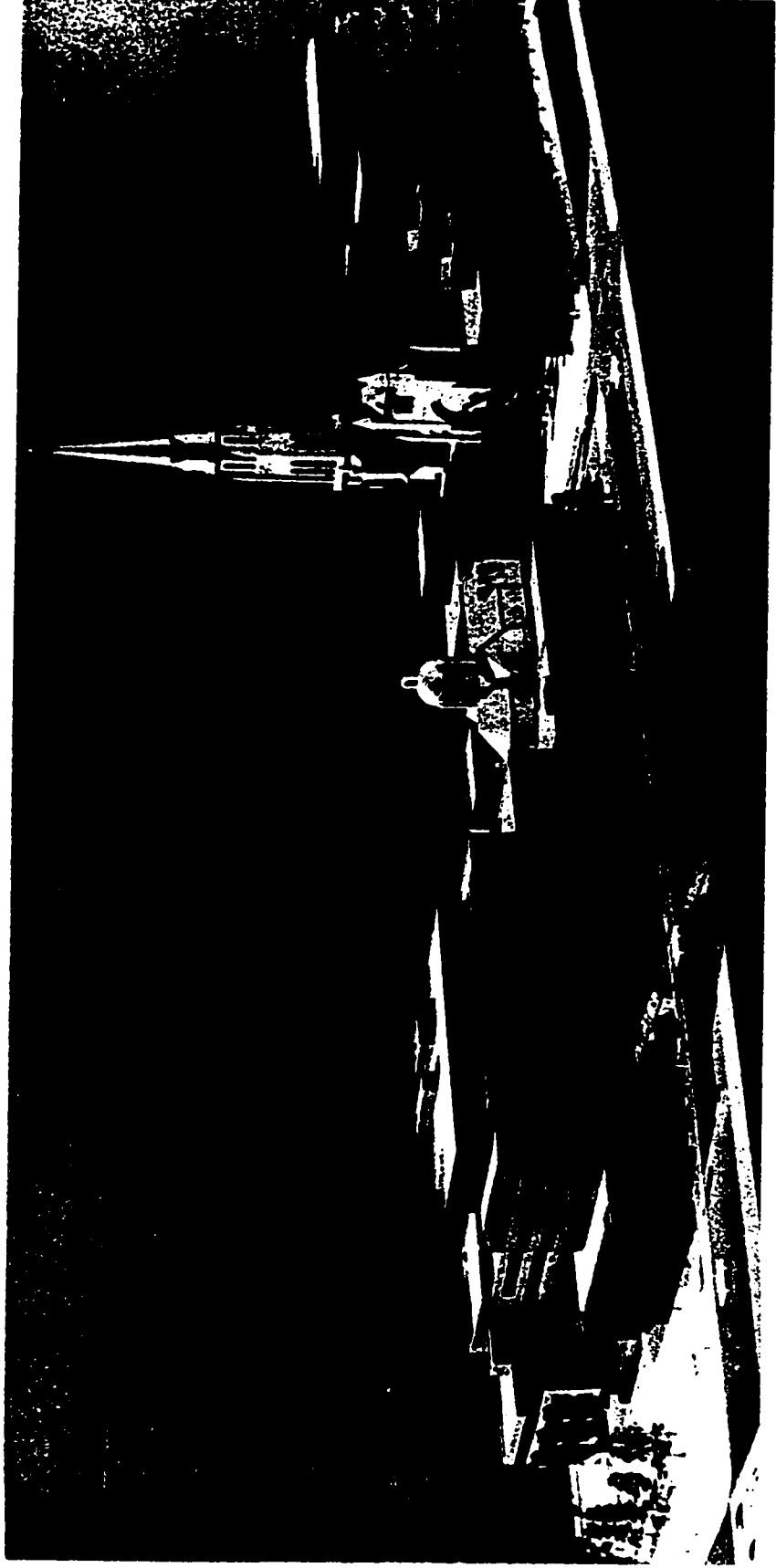

Fig. 54. Late Model. UQAM Phase I, Montreal, c.1975.

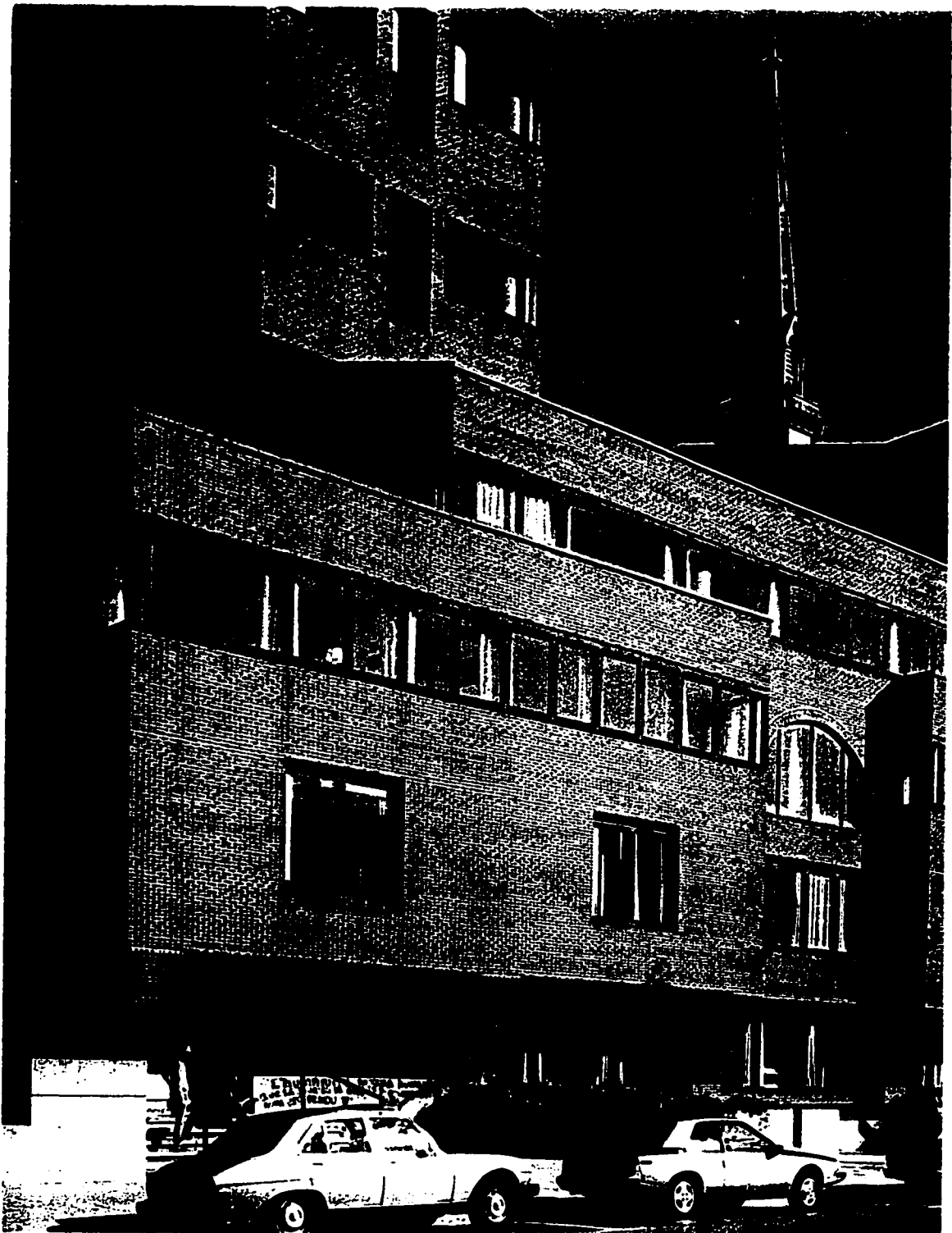

Fig.55. Brickwork. UQAM Phase I, Montreal, 1971-9.

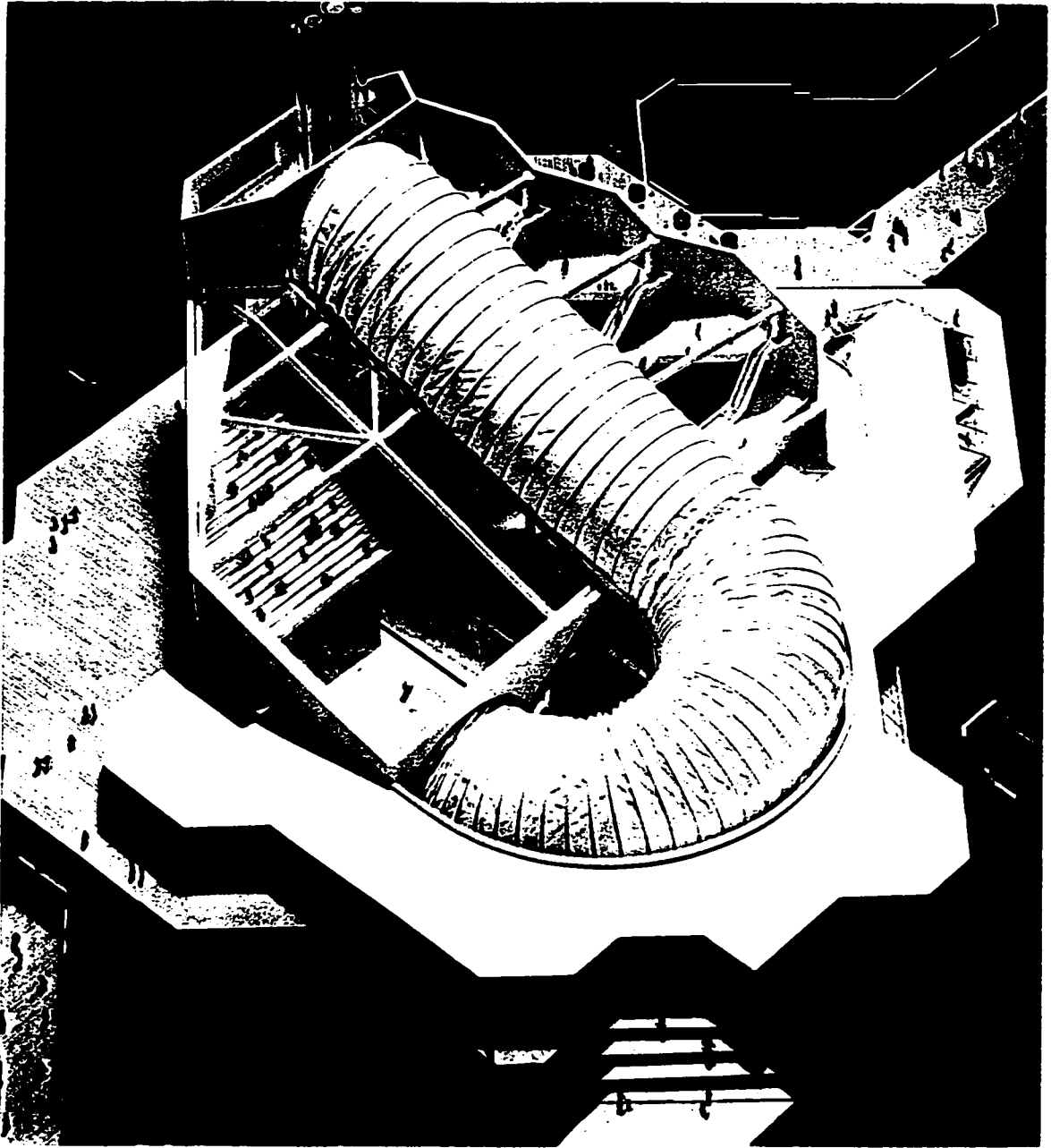

Fig. 56. Final Model. Winter Wondorlando Project, Orlando, Fla., 1974.

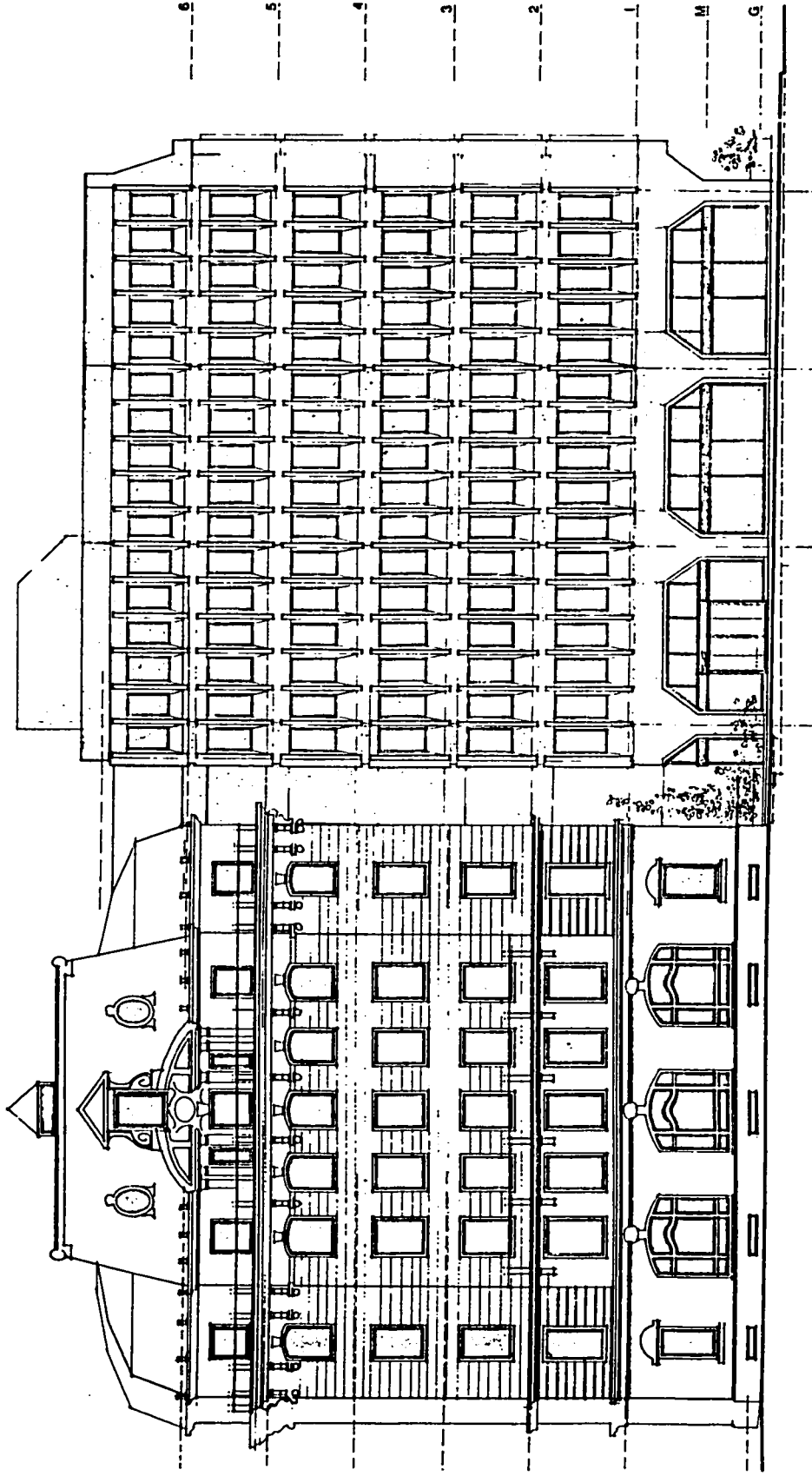

Fig. 57. Saint Jean Street Elevation. 244 St. James Street West Renovation/Expansion Project (London & Lancashire Building), Montreal, 1975.

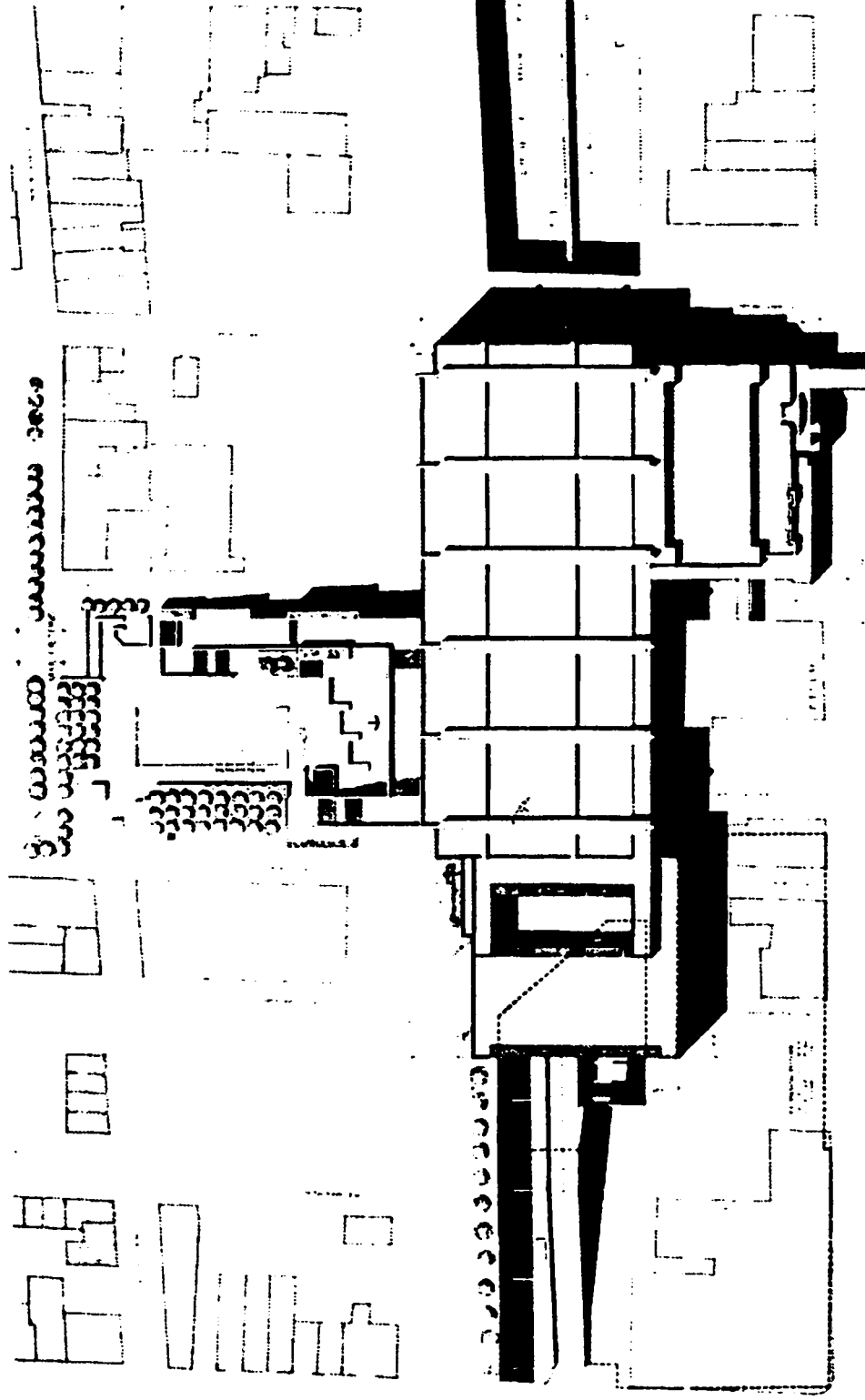

Fig. 58. Site Plan. Palais des Congrès, Montreal. Competition Project, 1978.



Fig. 59. Dimitri Dimakopoulos & Partners.

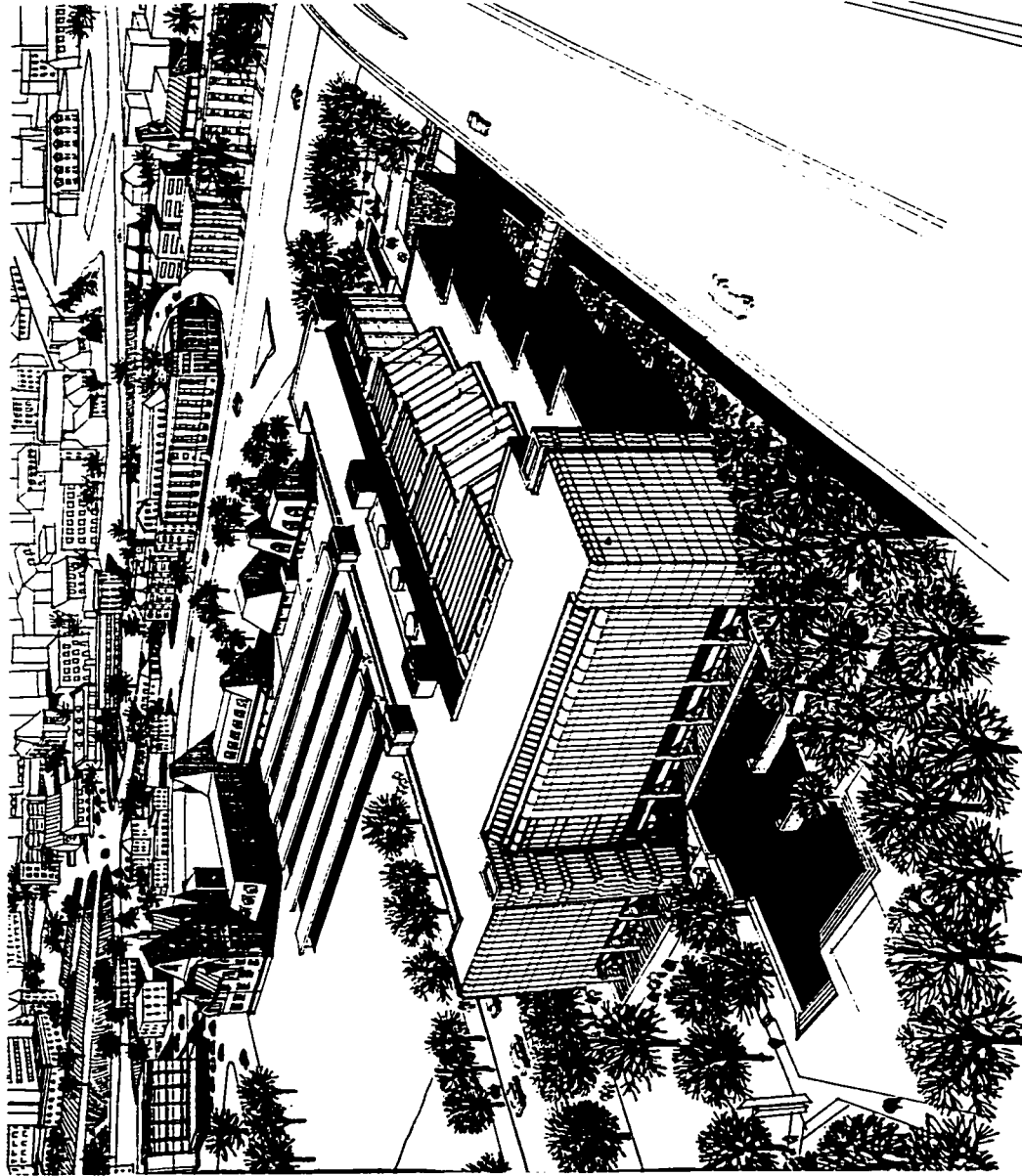

Fig. 60. Perspective. Palais de Justice de Québec Competition Project, 1979.



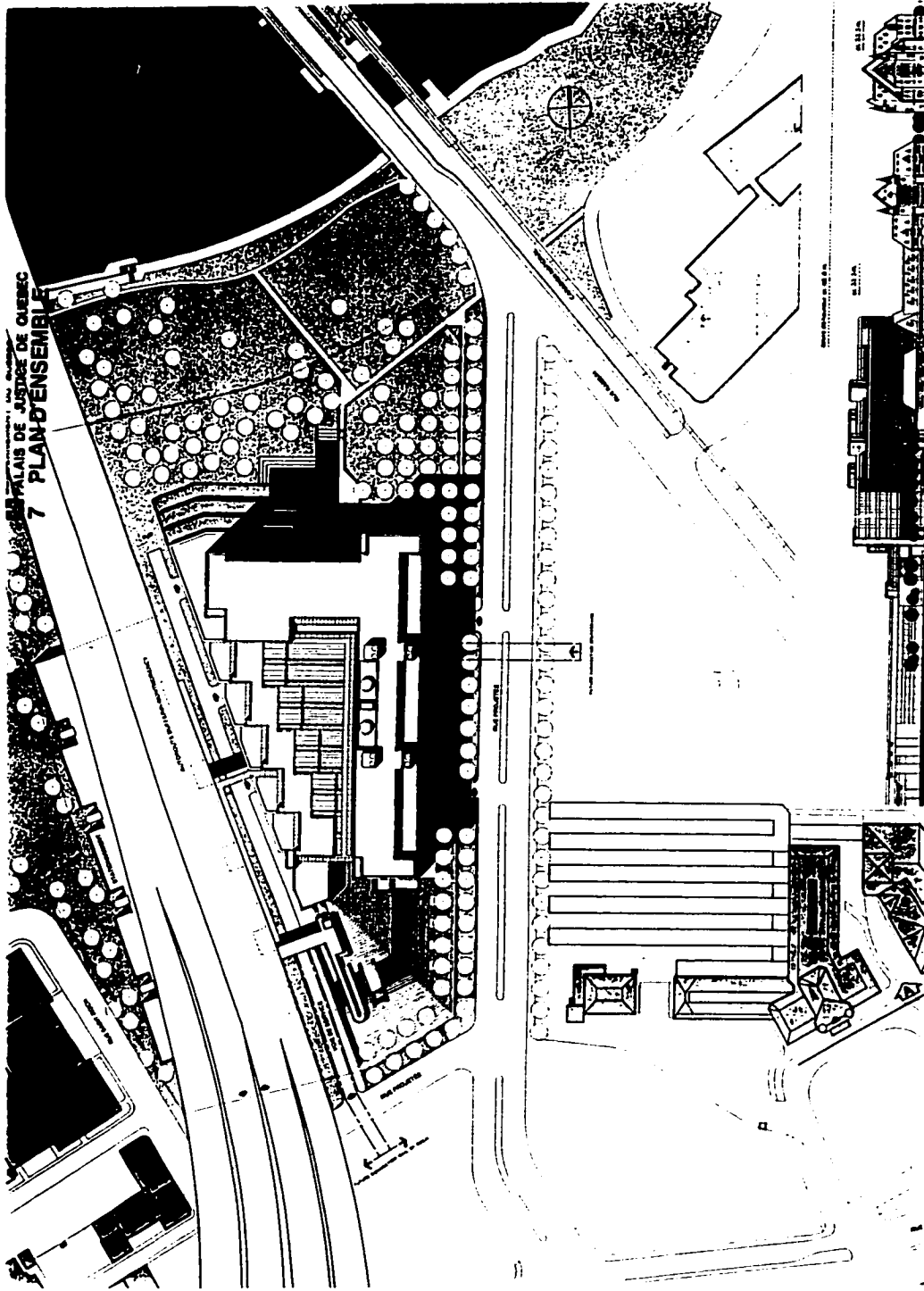

Fig. 61. Site Plan. Palais de Justice de Québec Competition Project, 1979.



Fig. 62. Dimitri with Model of Palais de Justice de Québec, August 1979.

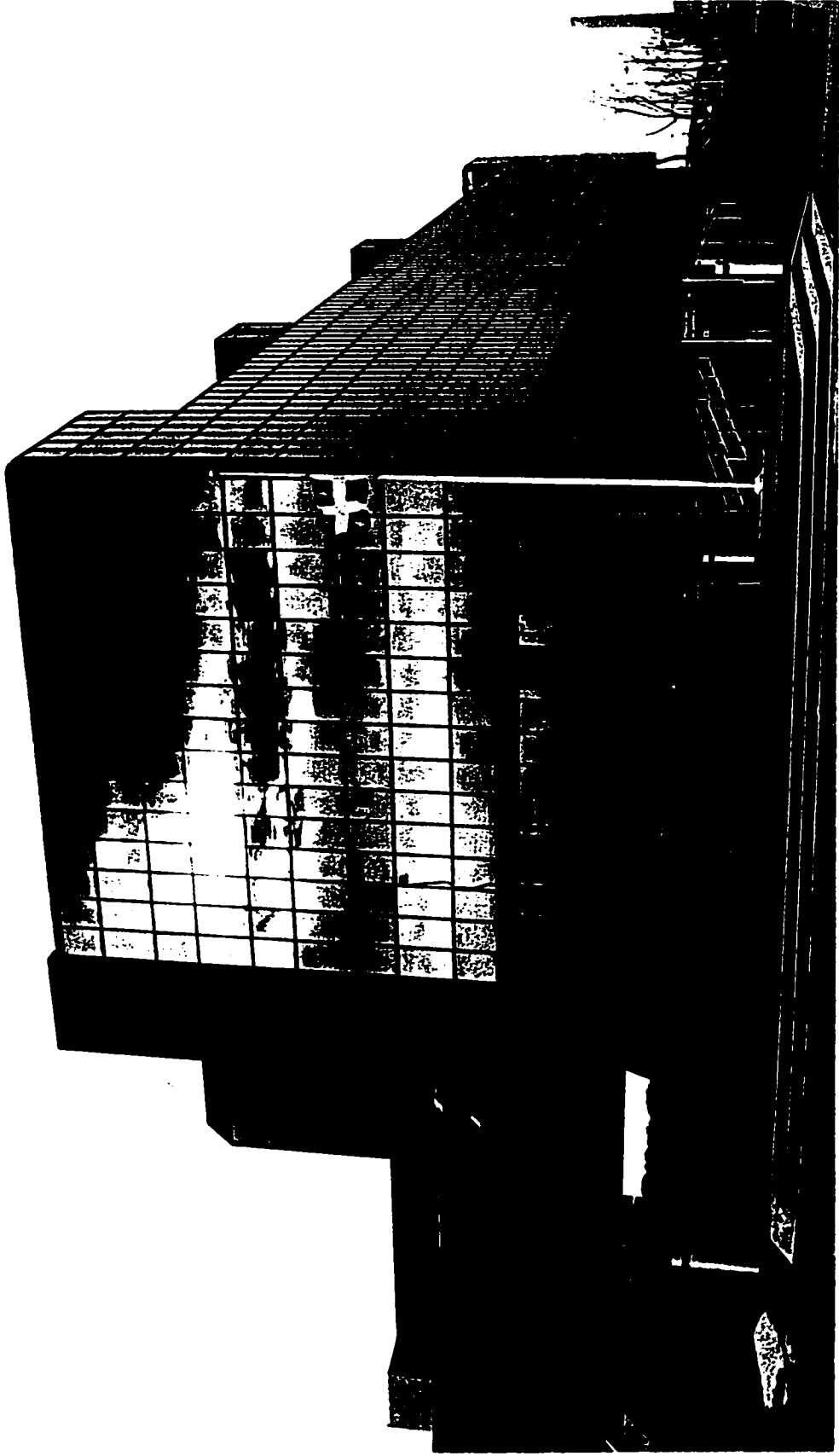

Fig. 63. Main Façades. Palais de Justice de Québec, 1979-83.

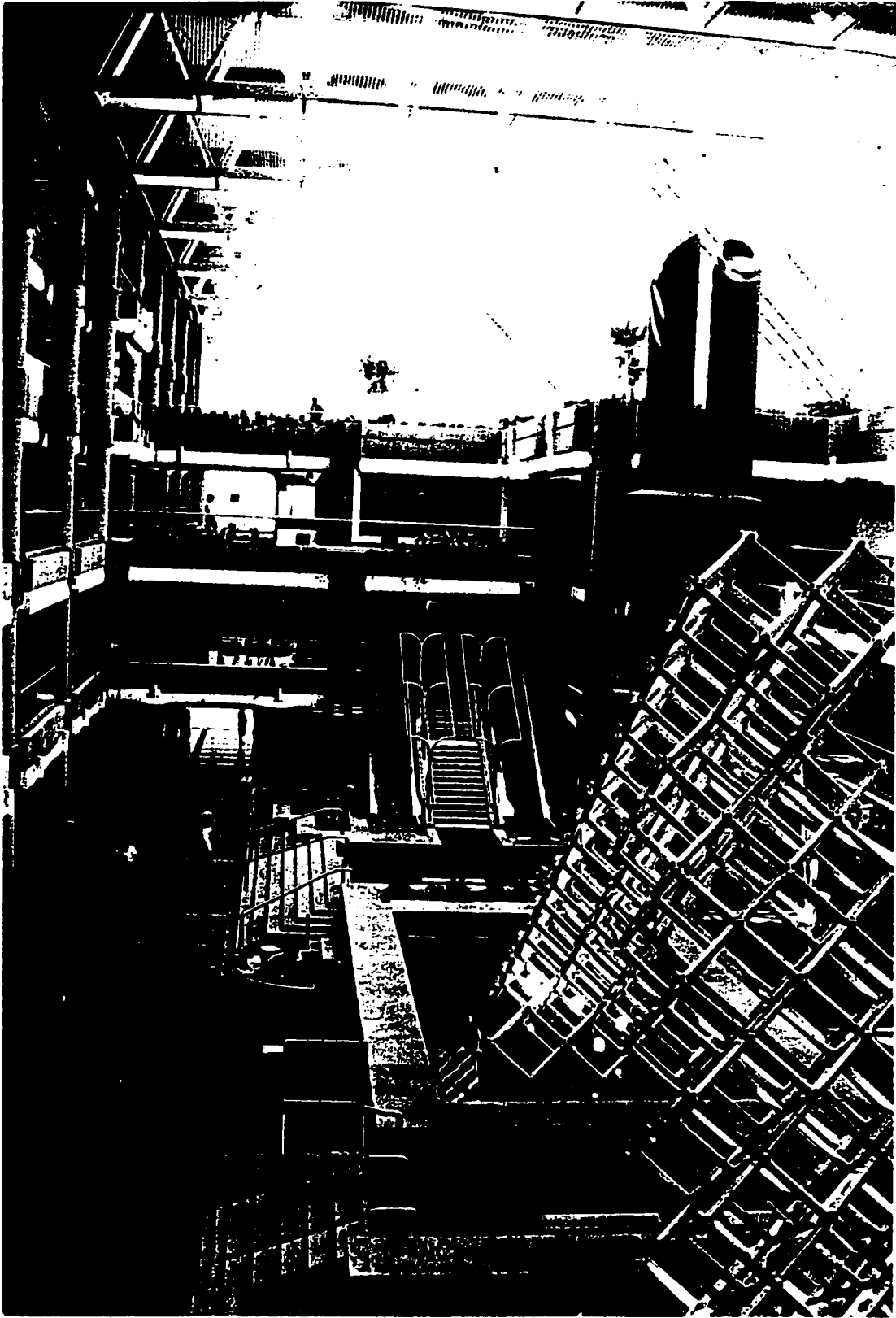

Fig. 64. Interior View on Atrium. Palais de Justice de Québec, 1979-83.



Fig. 65. Interior View on Freiman Mall, Ottawa, 1979-82.

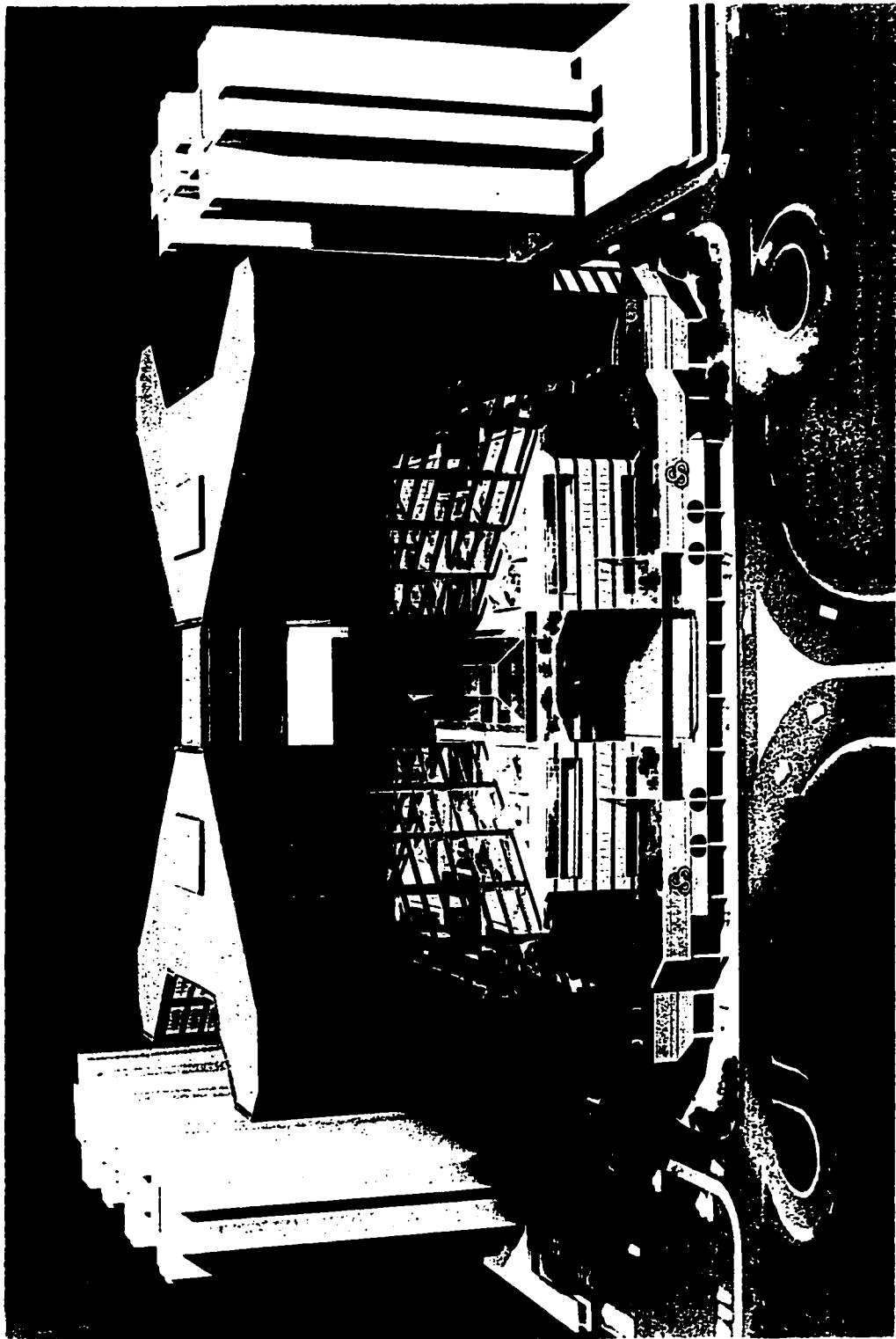

Fig. 66. Final Model. Taikoo Shing Site "B" Project, Hong Kong, 1980-1.

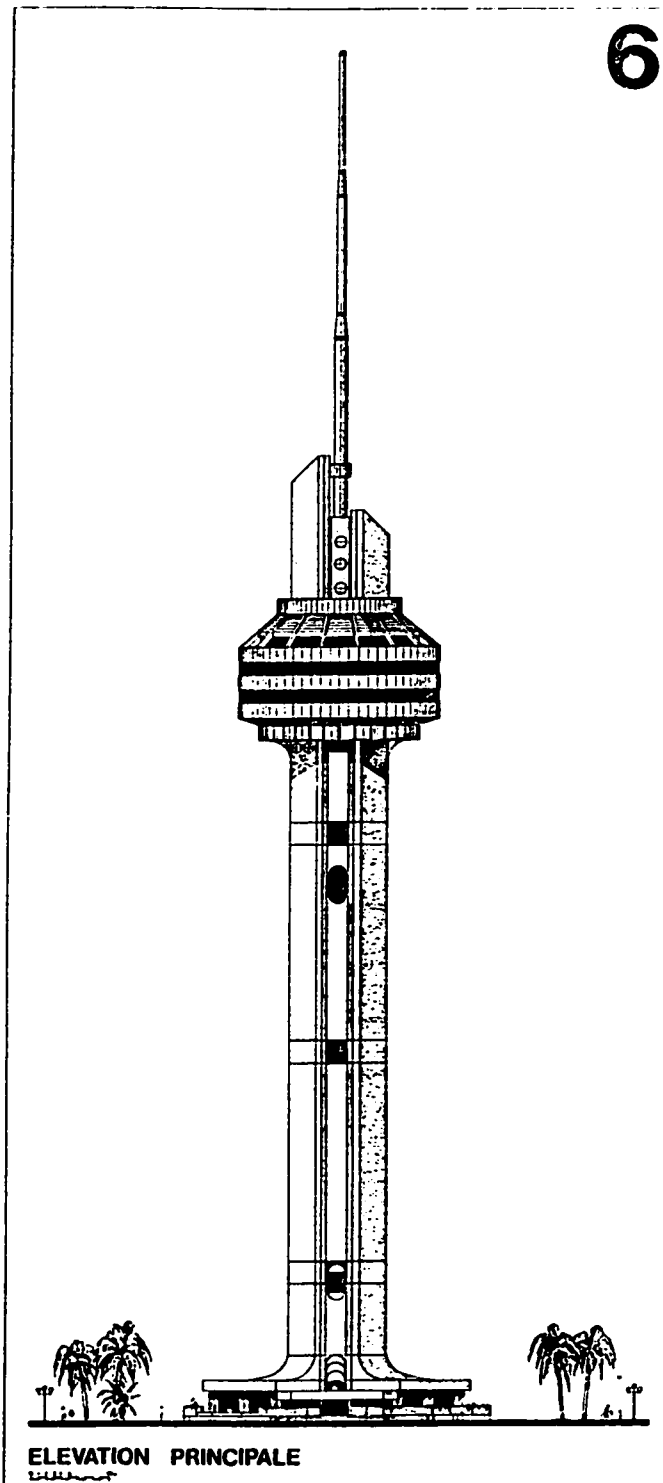

Fig. 67. Elevation. Tour Boumediene Competition Project, Algiers, 1980.

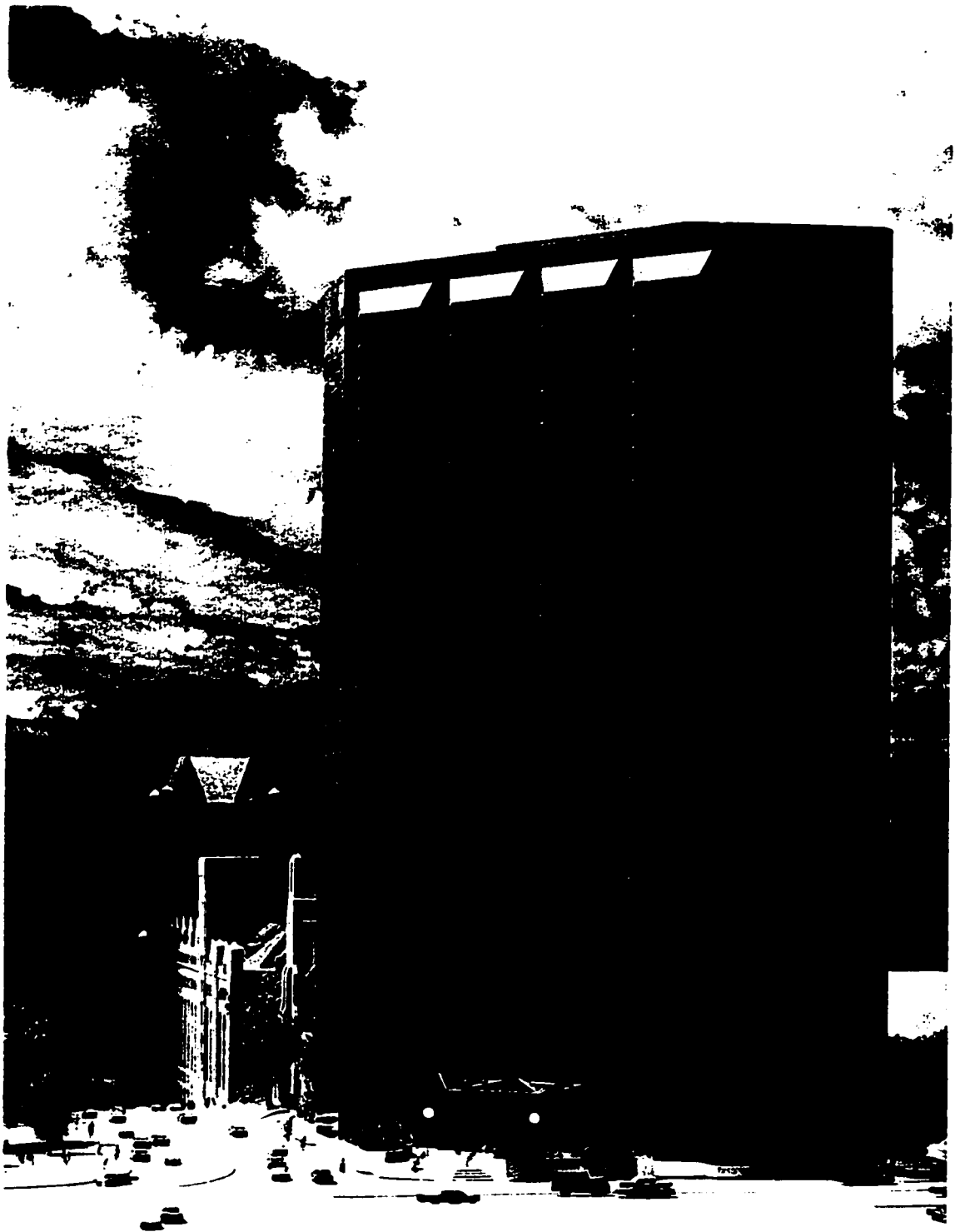

Fig. 68. Final Model. Edifice La Laurentienne, Montreal, 1980-6.



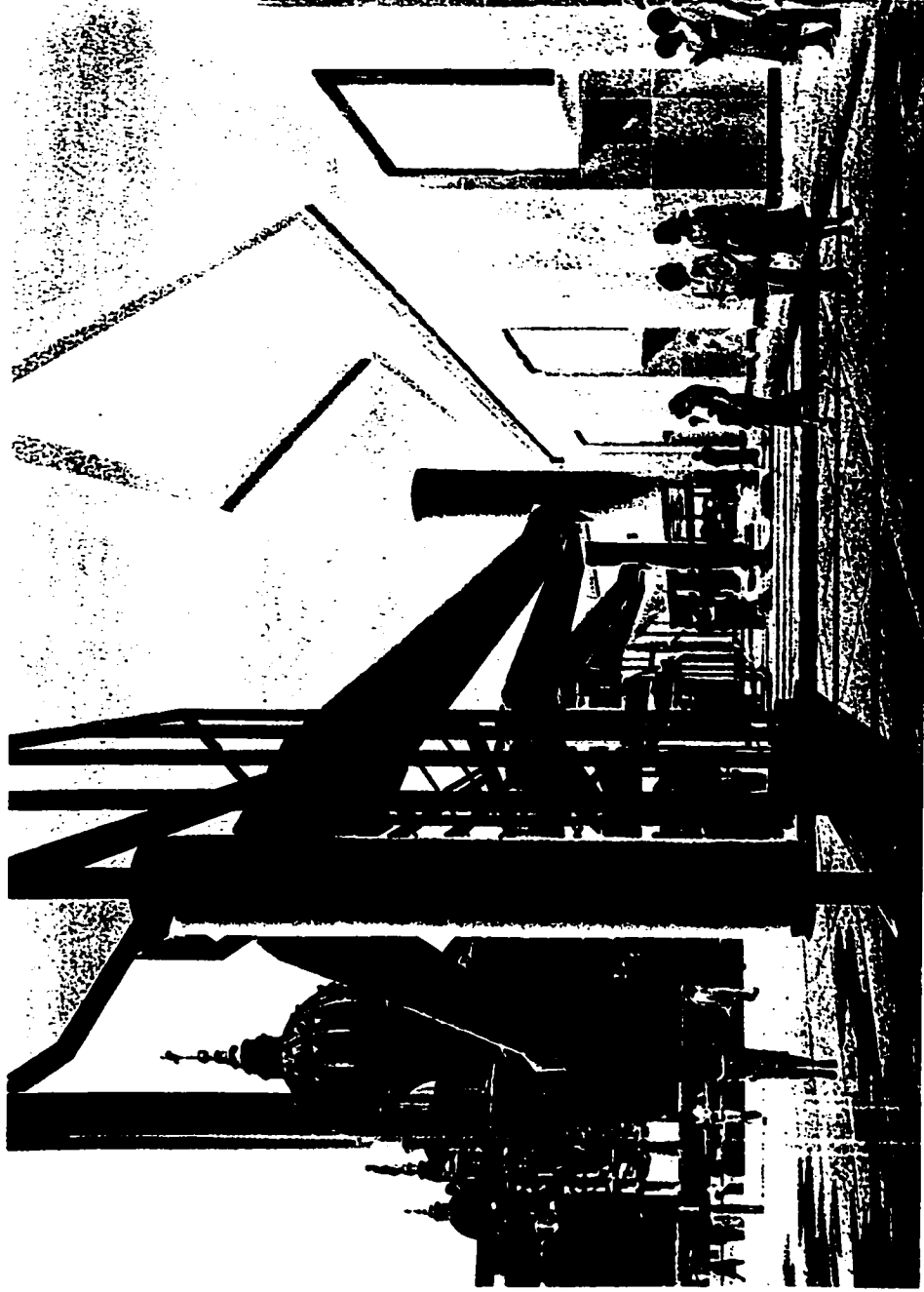

Fig. 69. Perspective. Entrance. Edifice La Laurentienne, Montreal, 1980-6.



Fig. 70. Lateral View. Edifice La Laurentienne, Montreal, 1980-6.



Fig. 71. Aerial View. Dawson College Atwater Campus, Montreal, 1982-8.

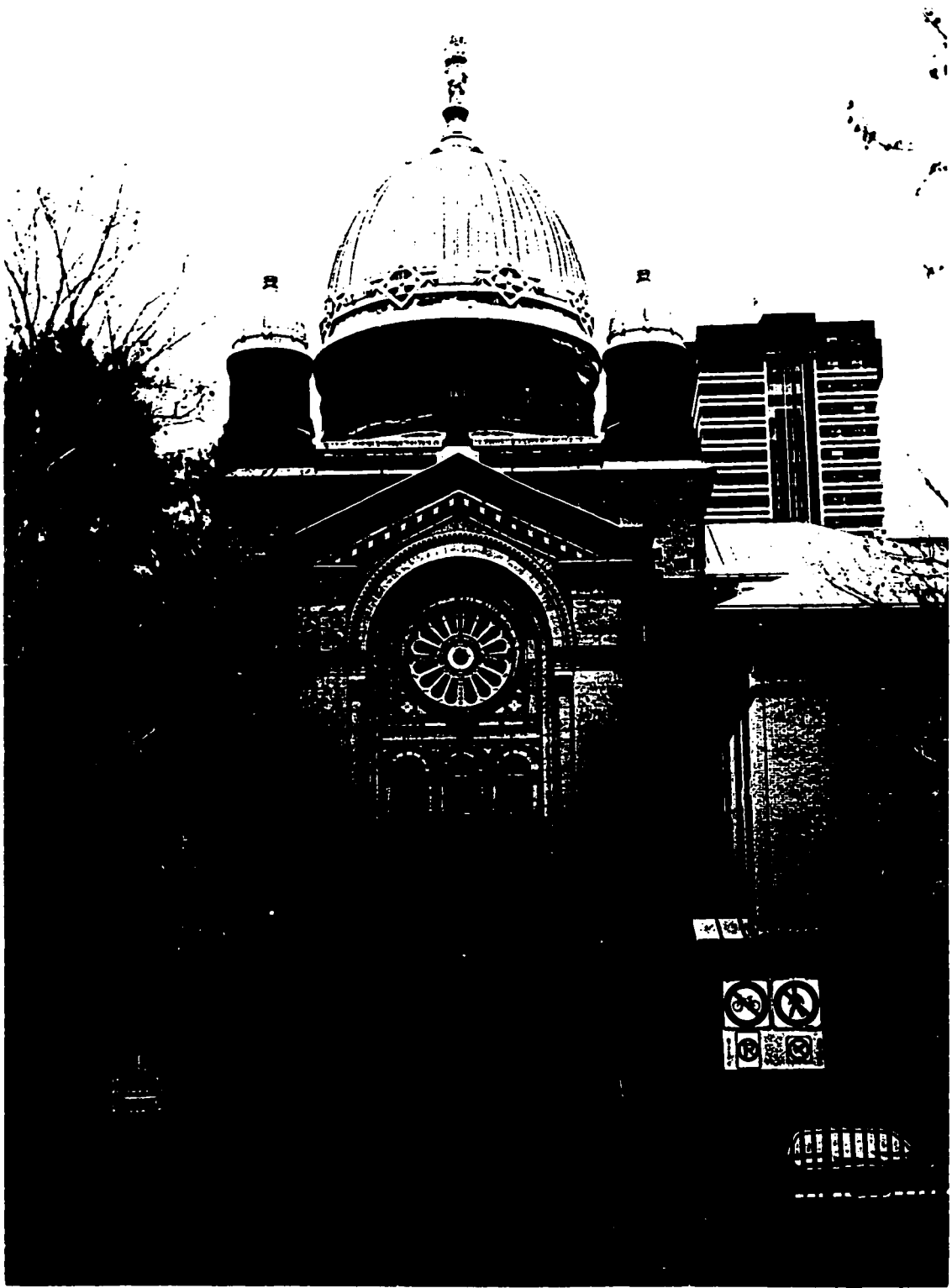

Fig. 72. Front Façade of Dawson College Library, Montreal, 1982-8.

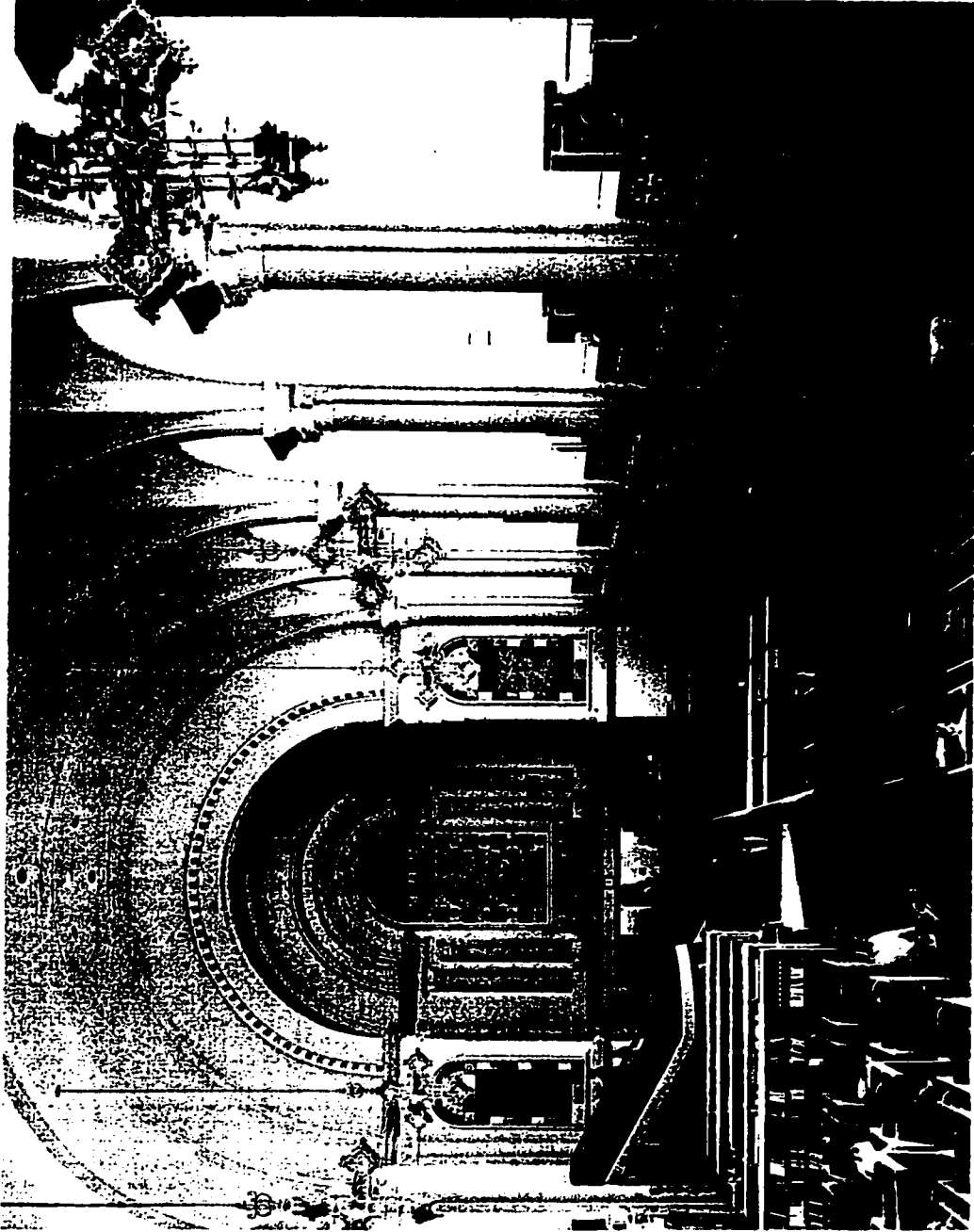

Fig. 73. Interior View of Dawson College Library, Montreal, 1982-8.

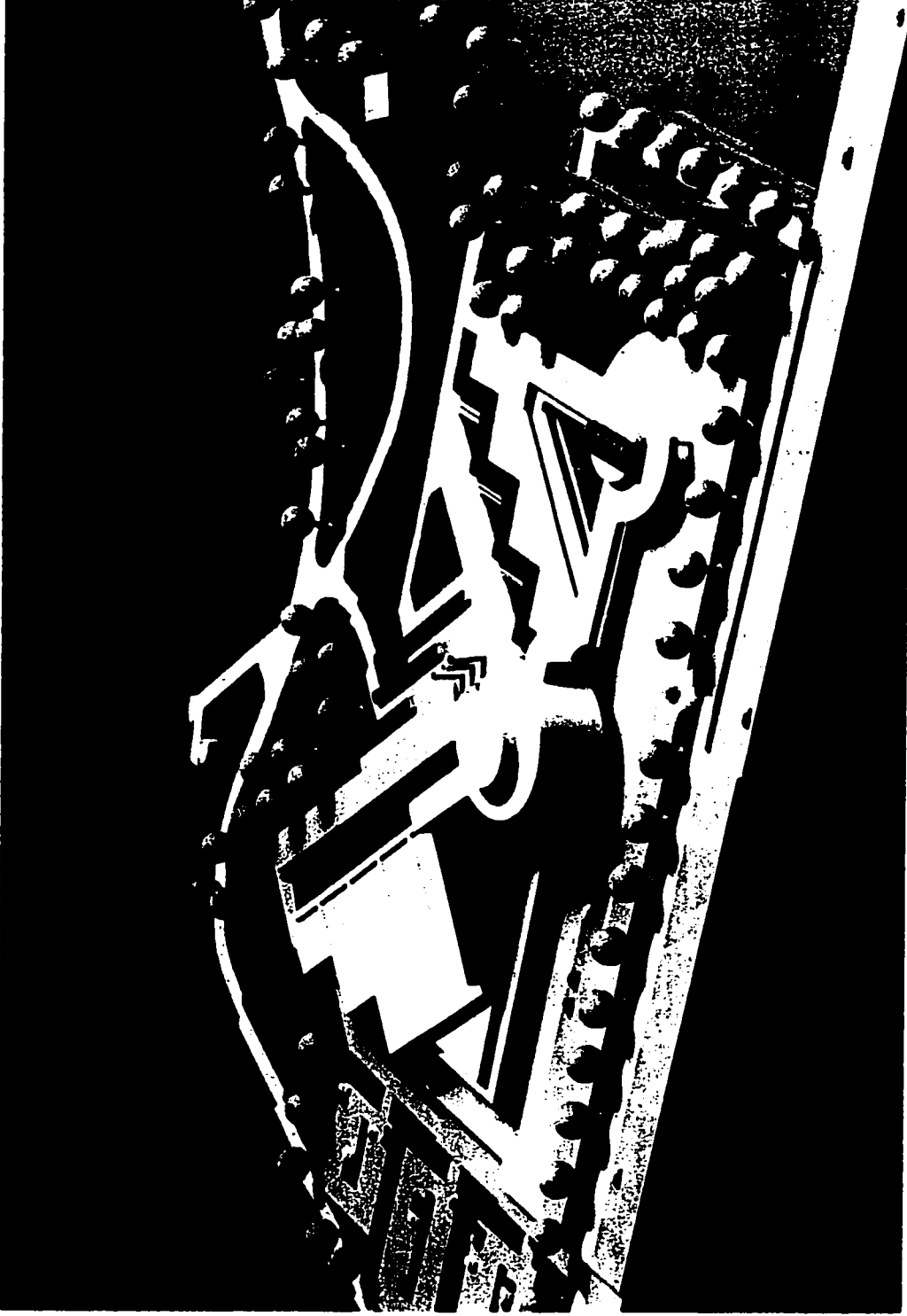

Fig. 74. Model. National Museum of Man Competition Project, Hull, 1982.

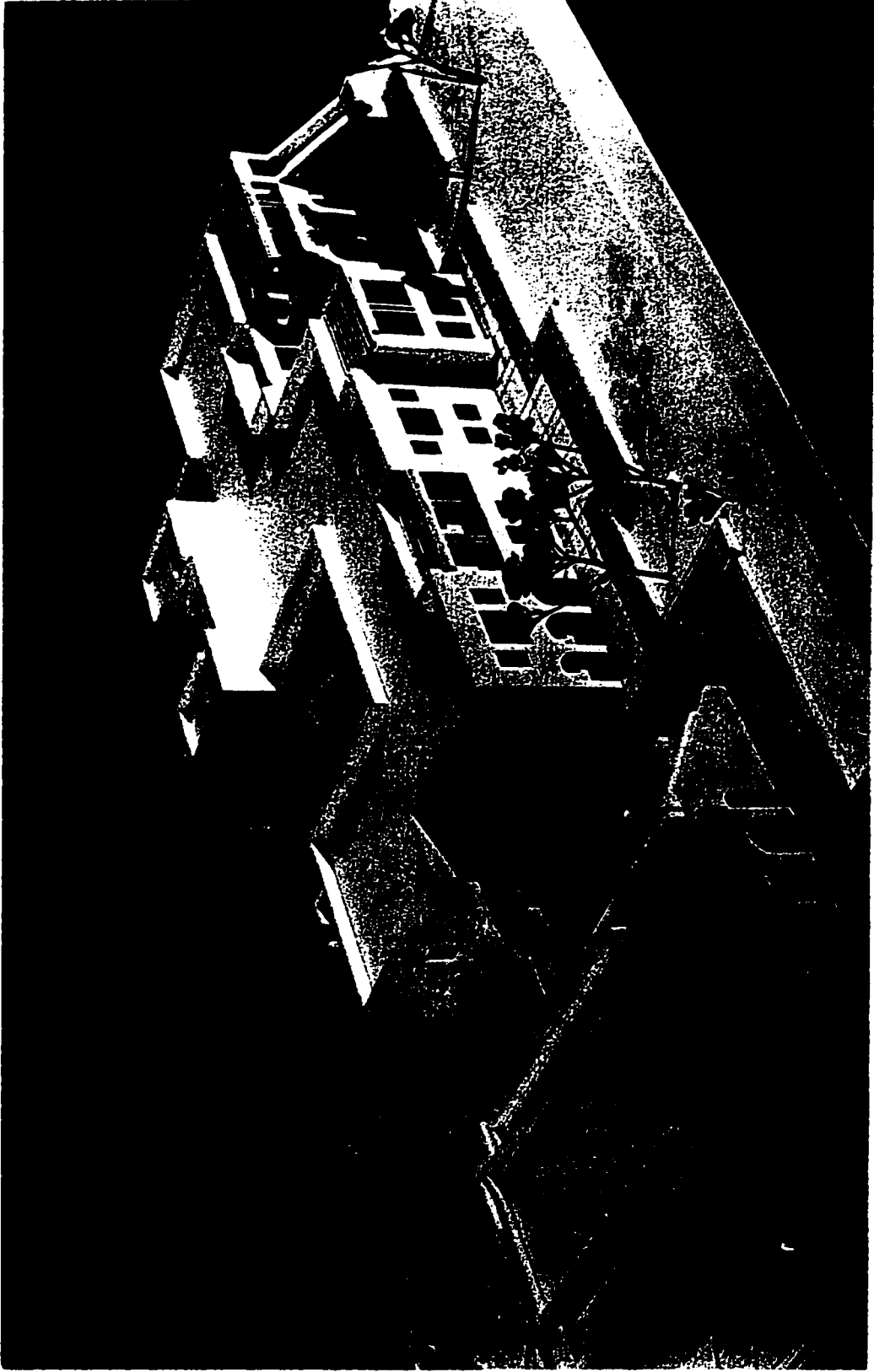

Fig. 75. Model. Yamani Residence, Manama, Bährein, 1983-4.

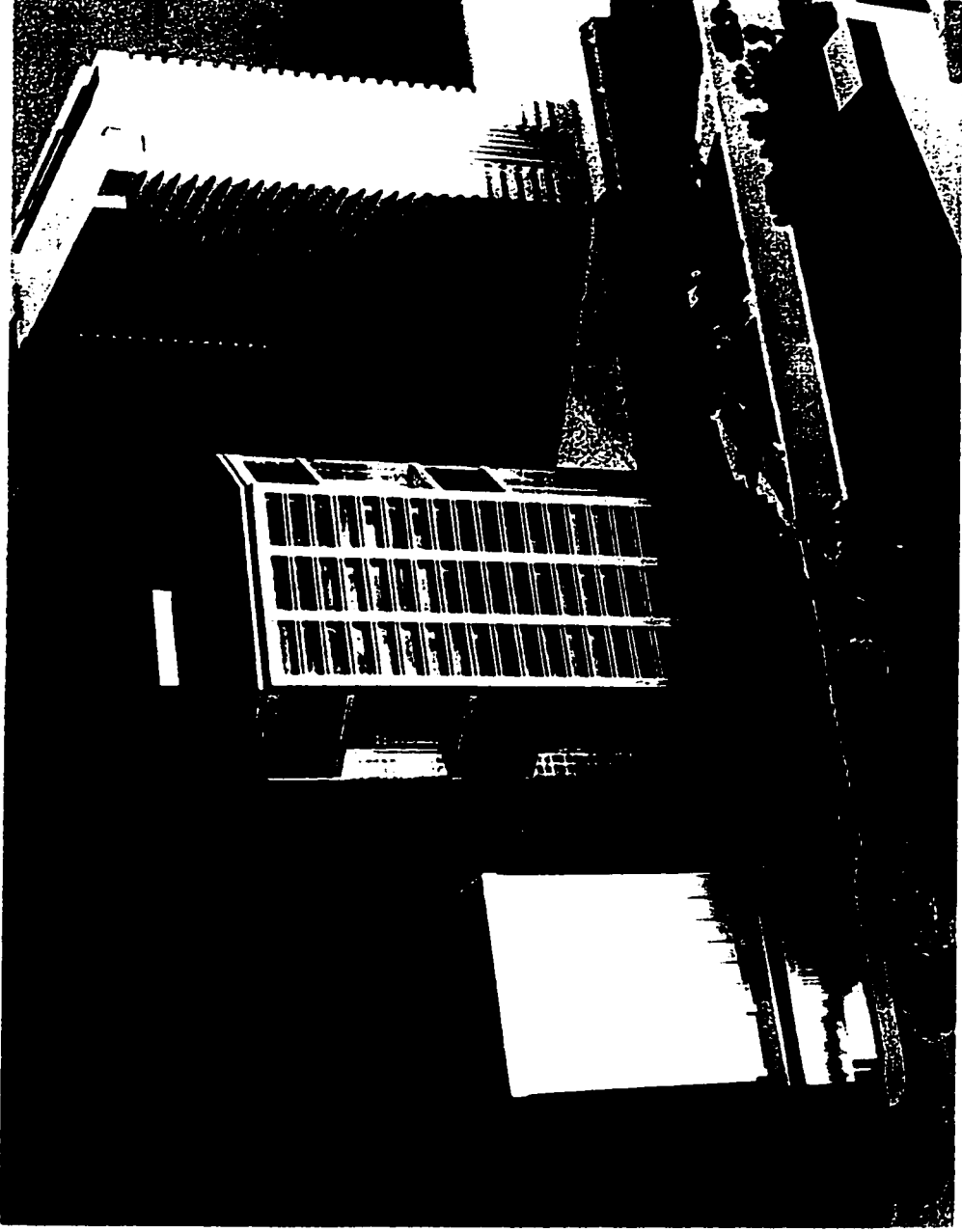

Fig. 76. Late Model. No. 2 Place Alexis Nihon, Montreal, 1983-6.



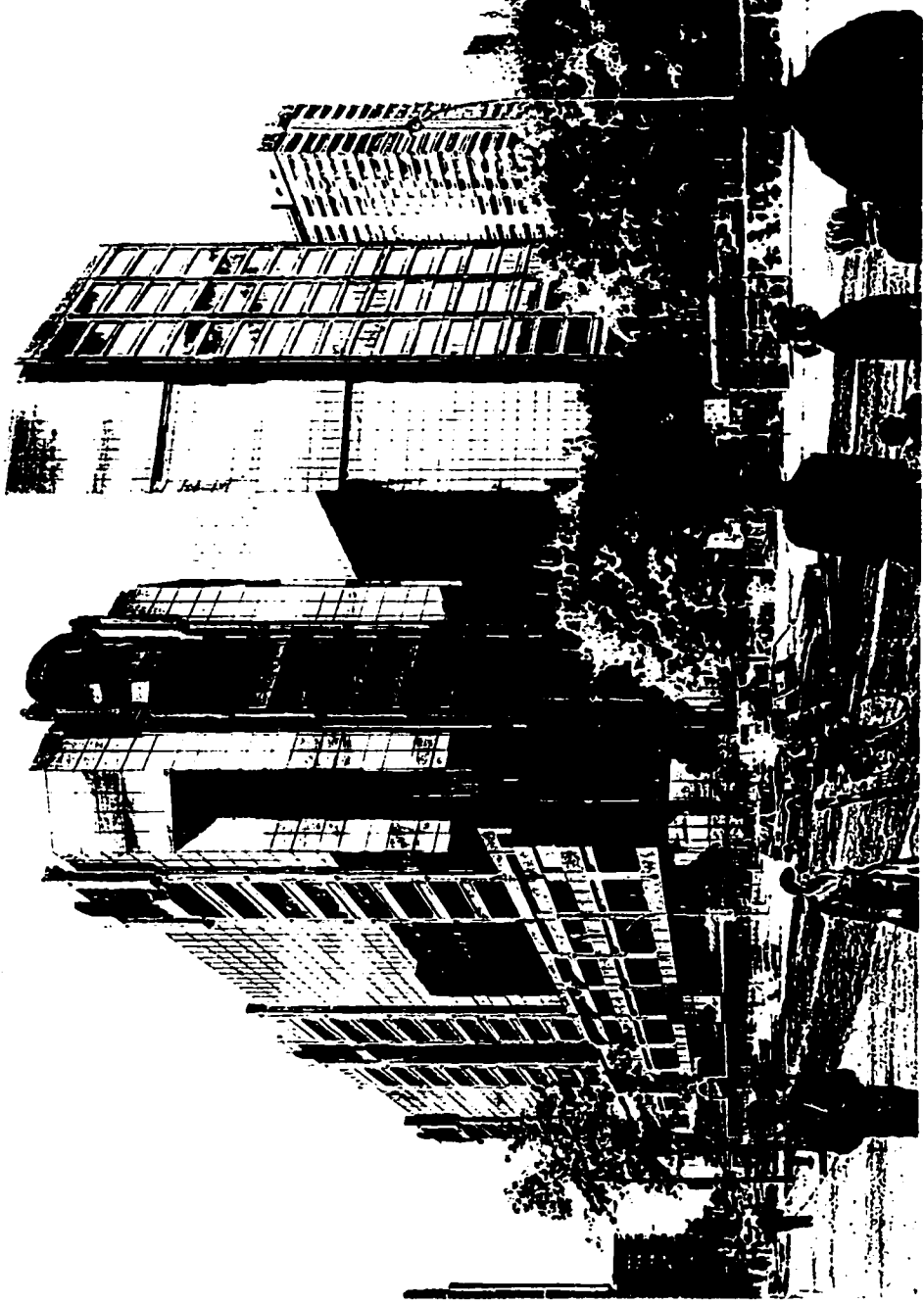

Fig. 77. Exterior Perspective. No 1 Place Alexis Nihon, Montreal, 1983-6.

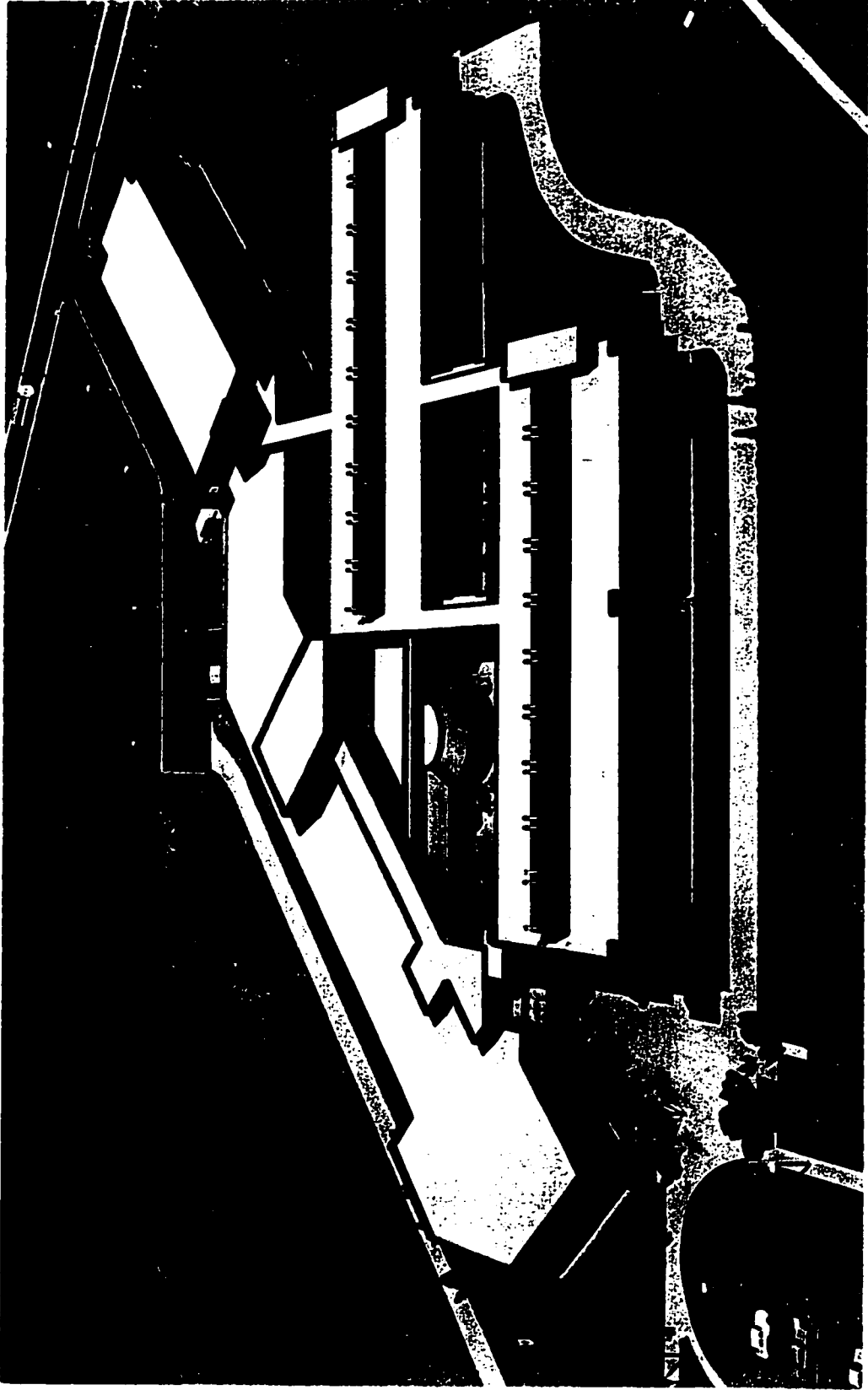

Fig. 78. Model. CNRC Bio-Technology Research Institute, Montreal, 1983-7.

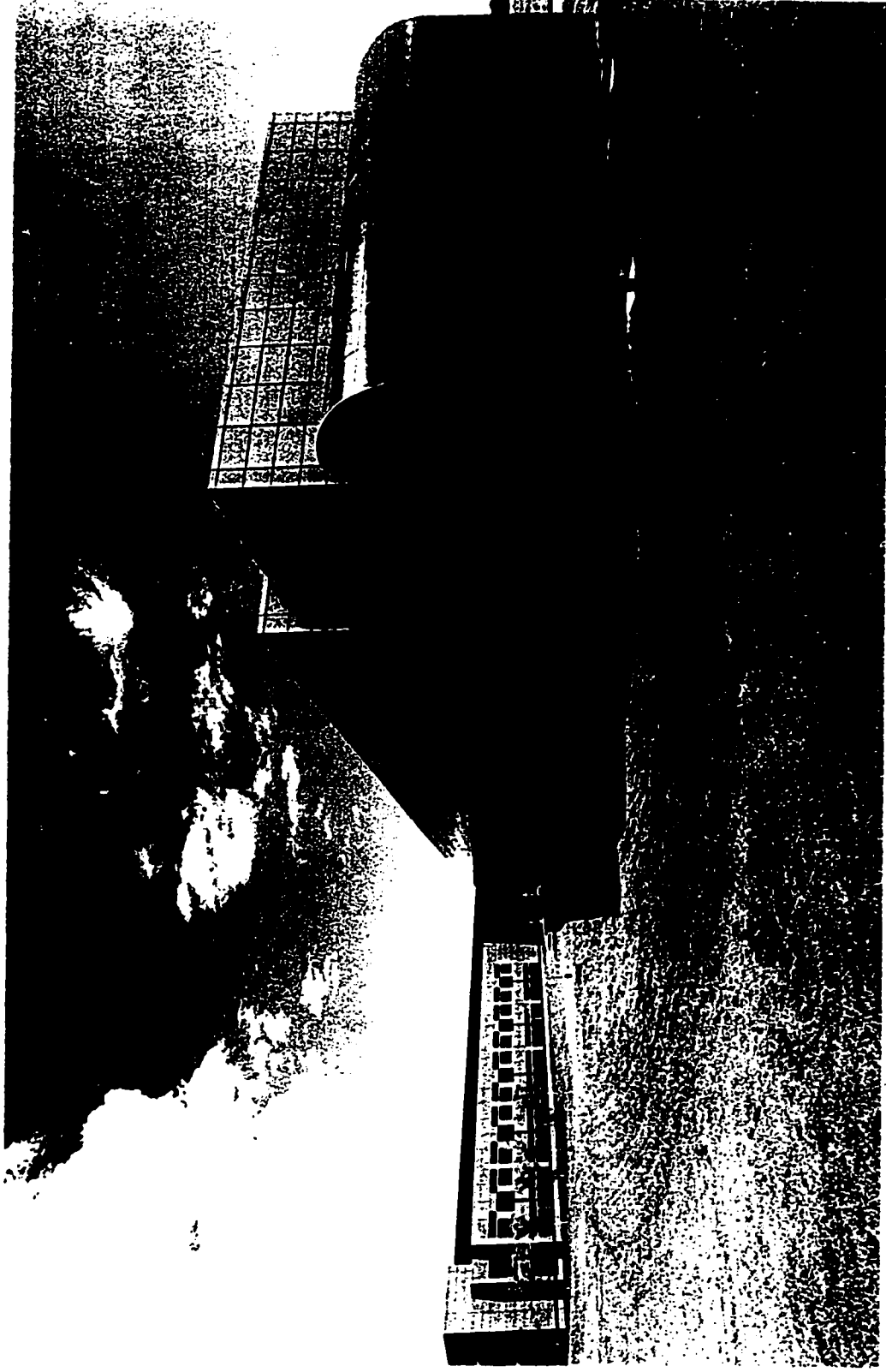

Fig. 79. Exterior View. CNRC Bio-Technology Research Institute, Montreal, 1983-7.

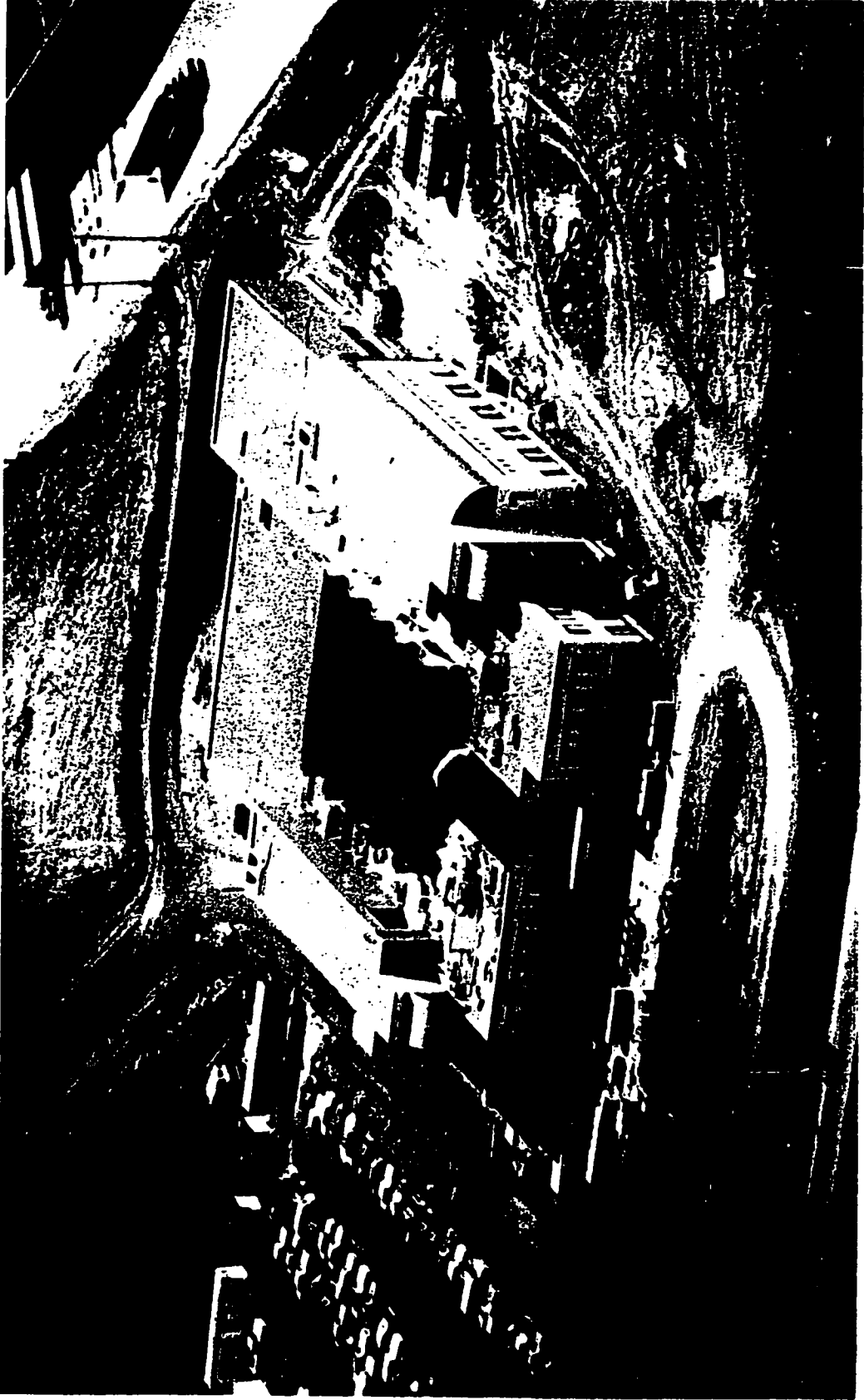

Fig. 80. Aerial View During Construction. Bio-Mega Laboratories, Laval, 1984-5.



Fig. 81. Interior View of Atrium. Bio-Mega Laboratories, Laval, 1984-5.

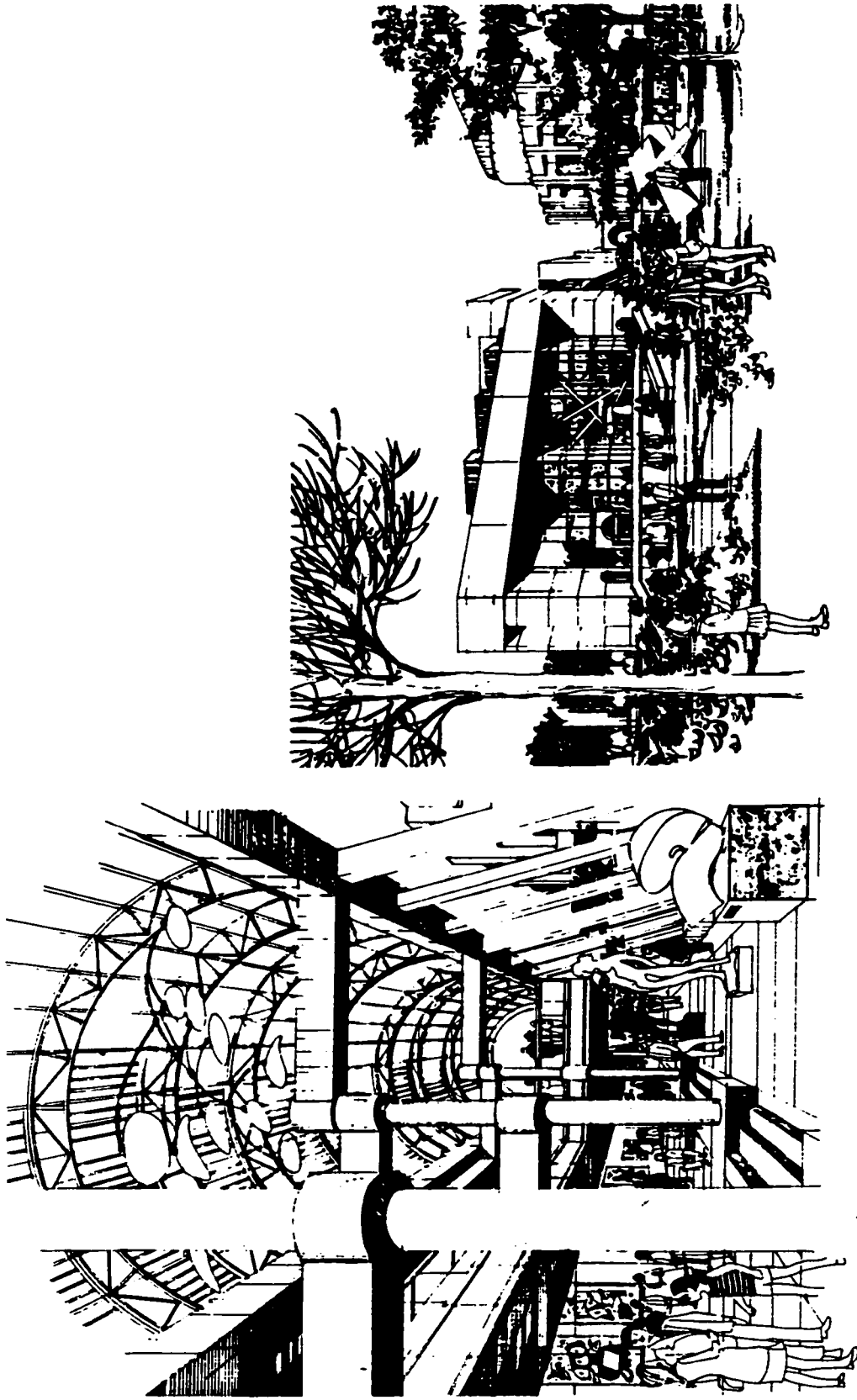

Fig. 82. Interior and Exterior Perspectives. Musée d'Art Contemporain de Montréal Competition Project, 1984.

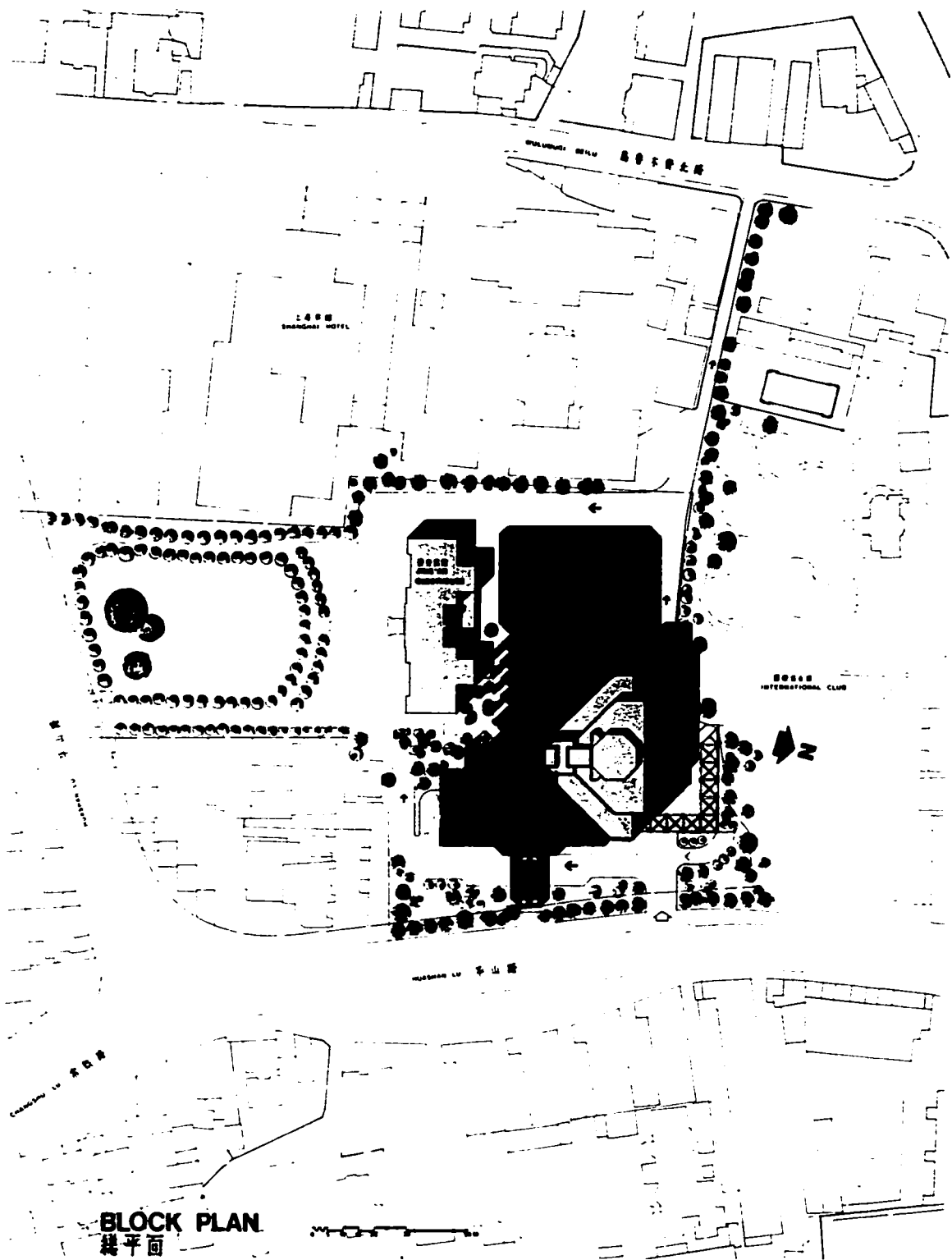

Fig. 83. Site Plan. Jing An Int'l Hilton Hotel, Shanghai, 1984.

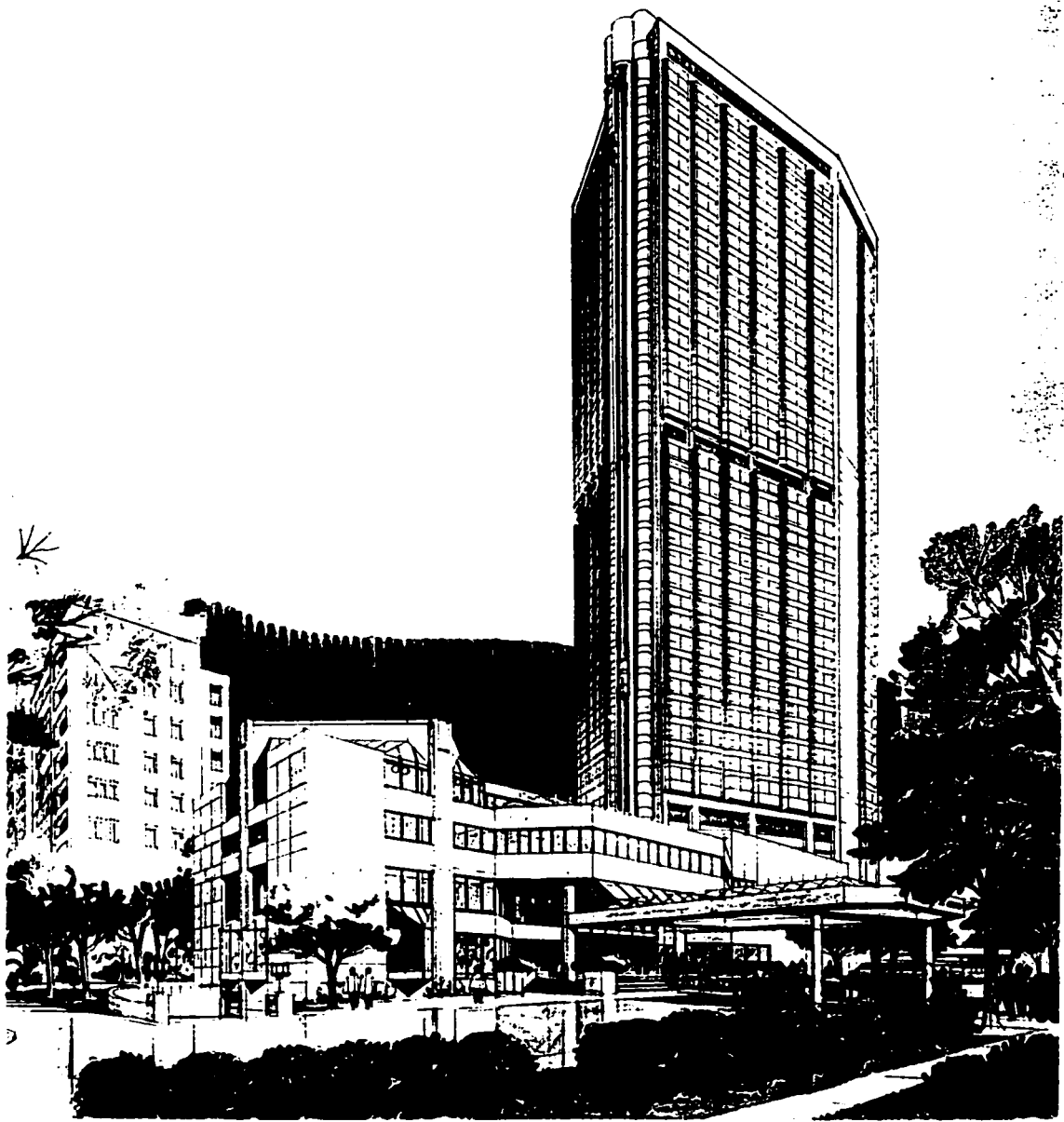

Fig. 84. Exterior Perspective. Jing An Int'l Hilton Hotel, Shanghai, 1984.





Fig. 85. Place Pasteur Perspective. UQAM Phase II, Montreal, 1985-92.

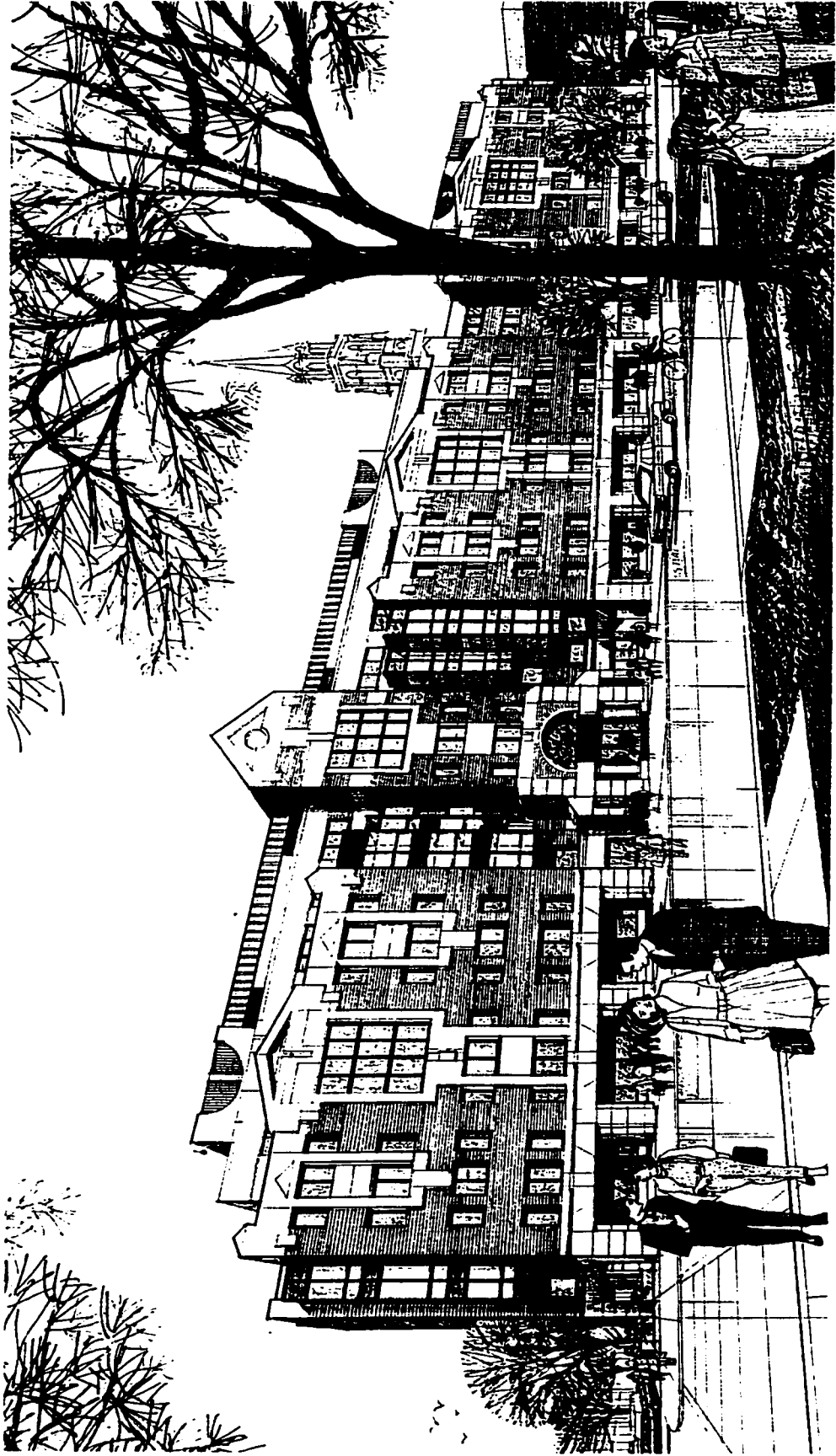

Fig. 86. Ste. Catherine Street Perspective. UQAM Phase II, Montreal 1985-92.

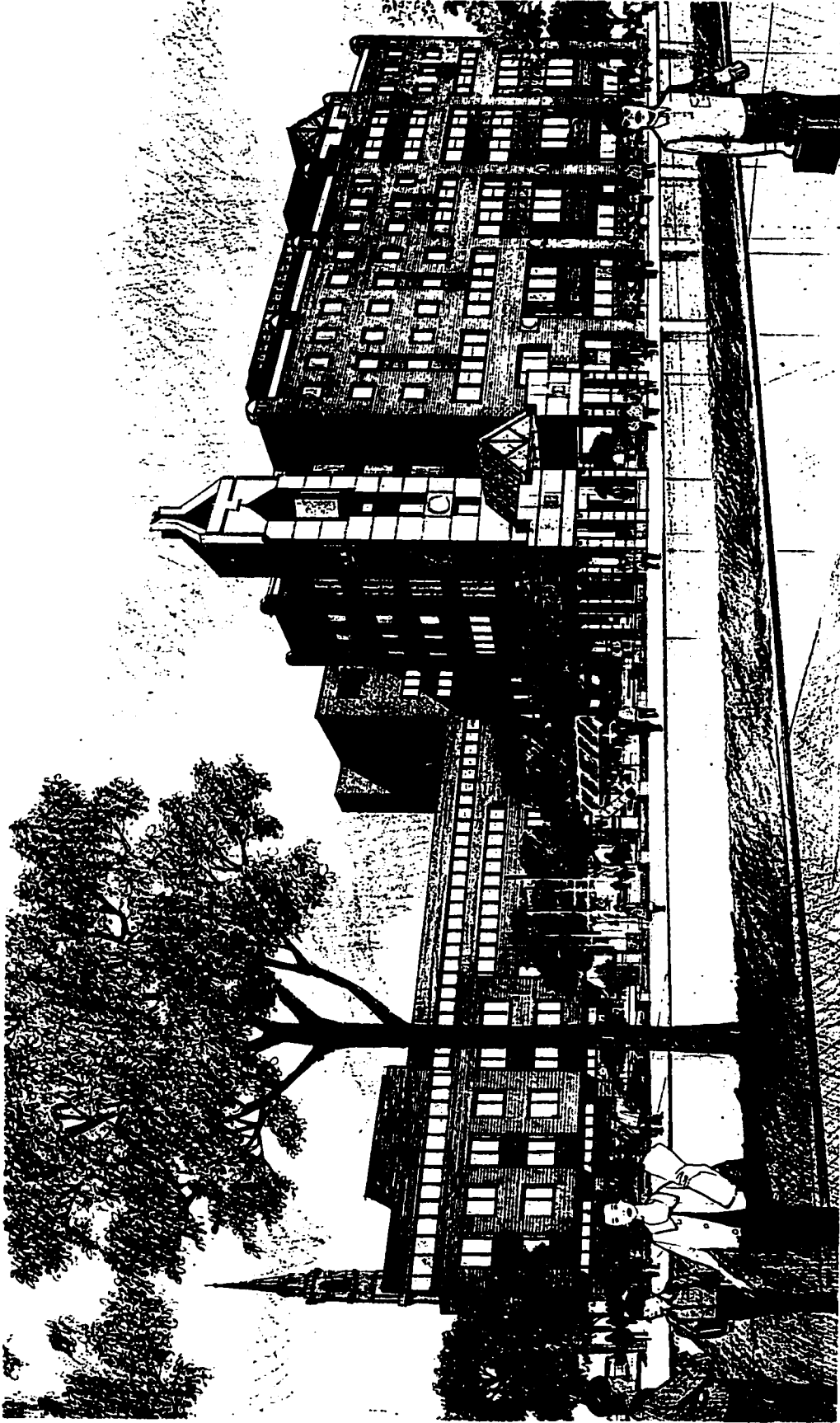

Fig. 87. Dorchester Boulevard Perspective. UQAM Phase II, Montreal, 1985-92.



Fig. 88. Interior View of Rehearsal Room, Salle Wilfrid Pelletier Expansion, Place des Arts, Montreal, 1987-92.

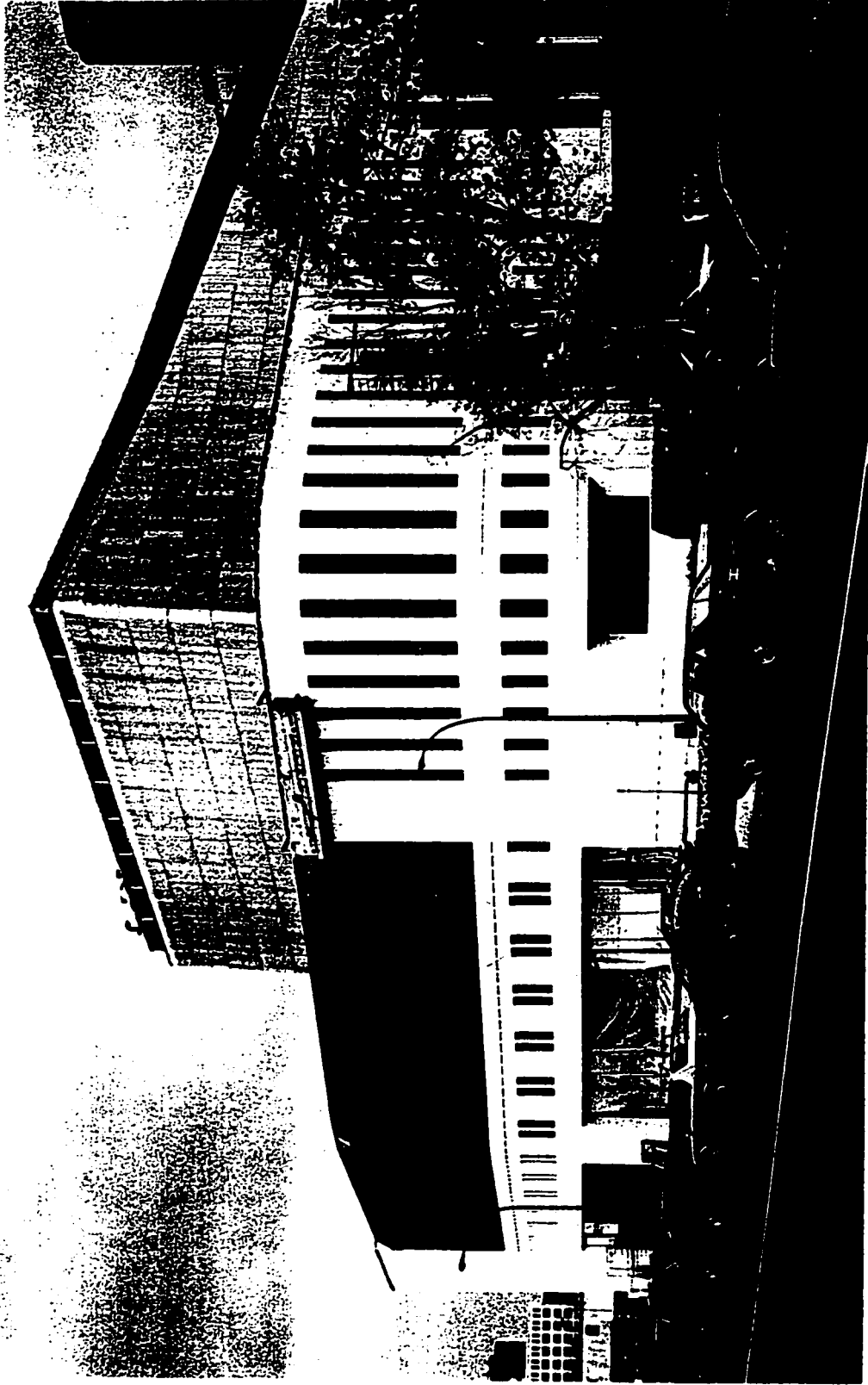

Fig. 89. Exterior View of Addition. Salle Wilfrid Pelletier Expansion, Place des Arts, Montreal, 1987-92.

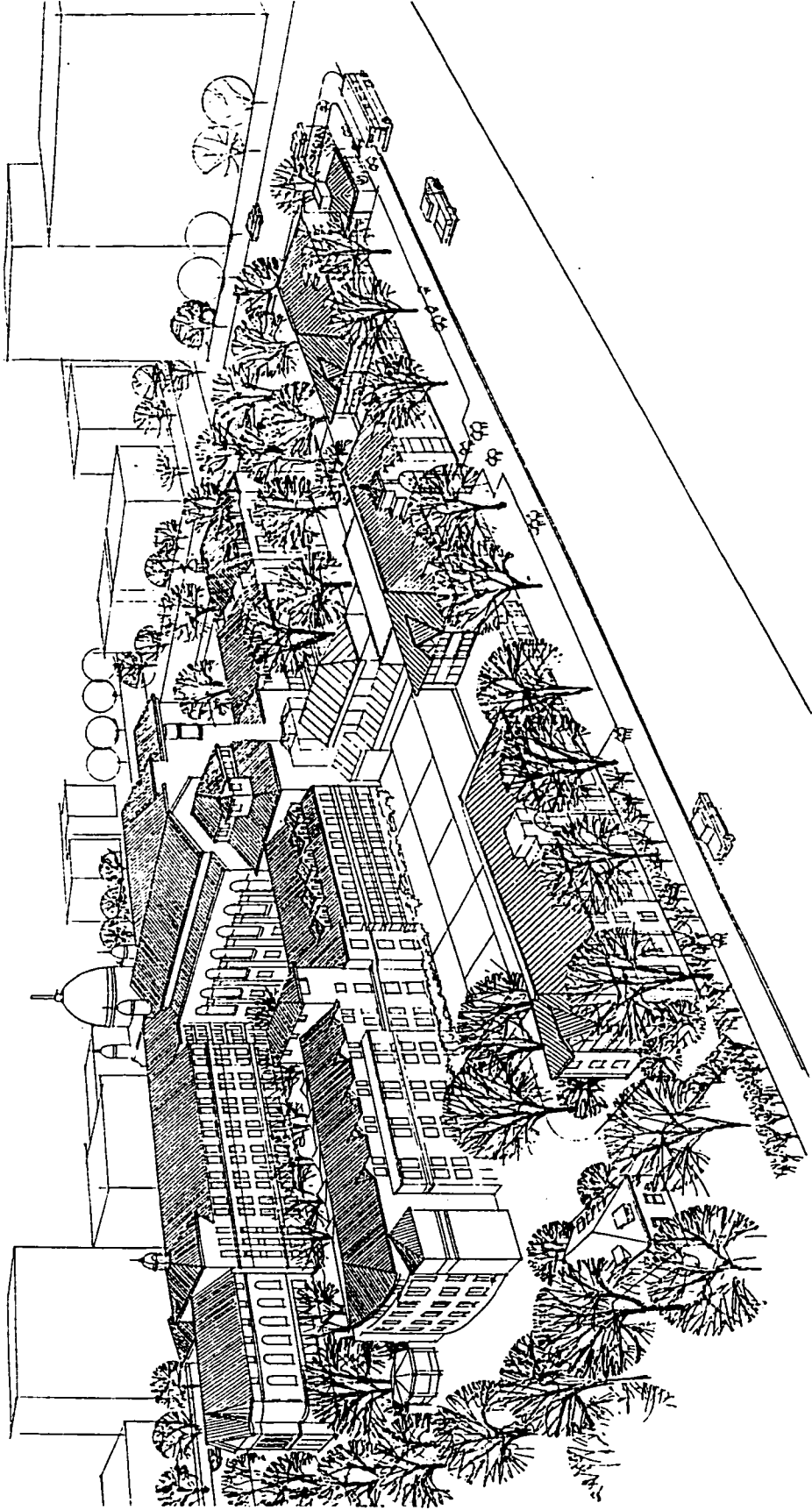

Fig. 90. Aerial Perspective of the Completed Atwater Campus, Dawson College Phase III, Montreal, 1988-90.



Fig. 91. Exterior View of the Phase III Wing. Dawson College Phase III, Montreal, 1988-90.

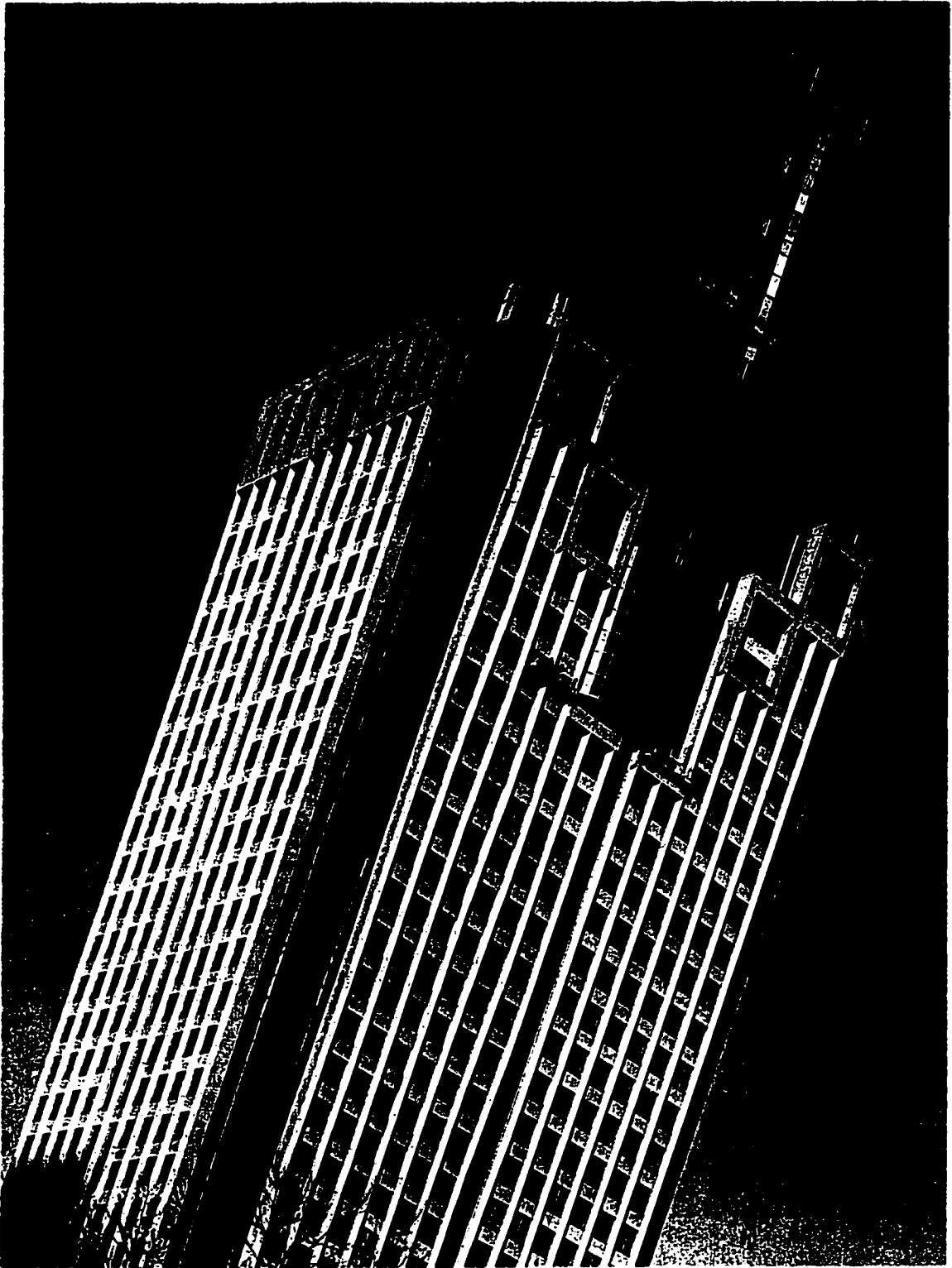

Fig. 92. Upper Shaft and Crown. Le 1000 de La Gauchetière, Montreal.



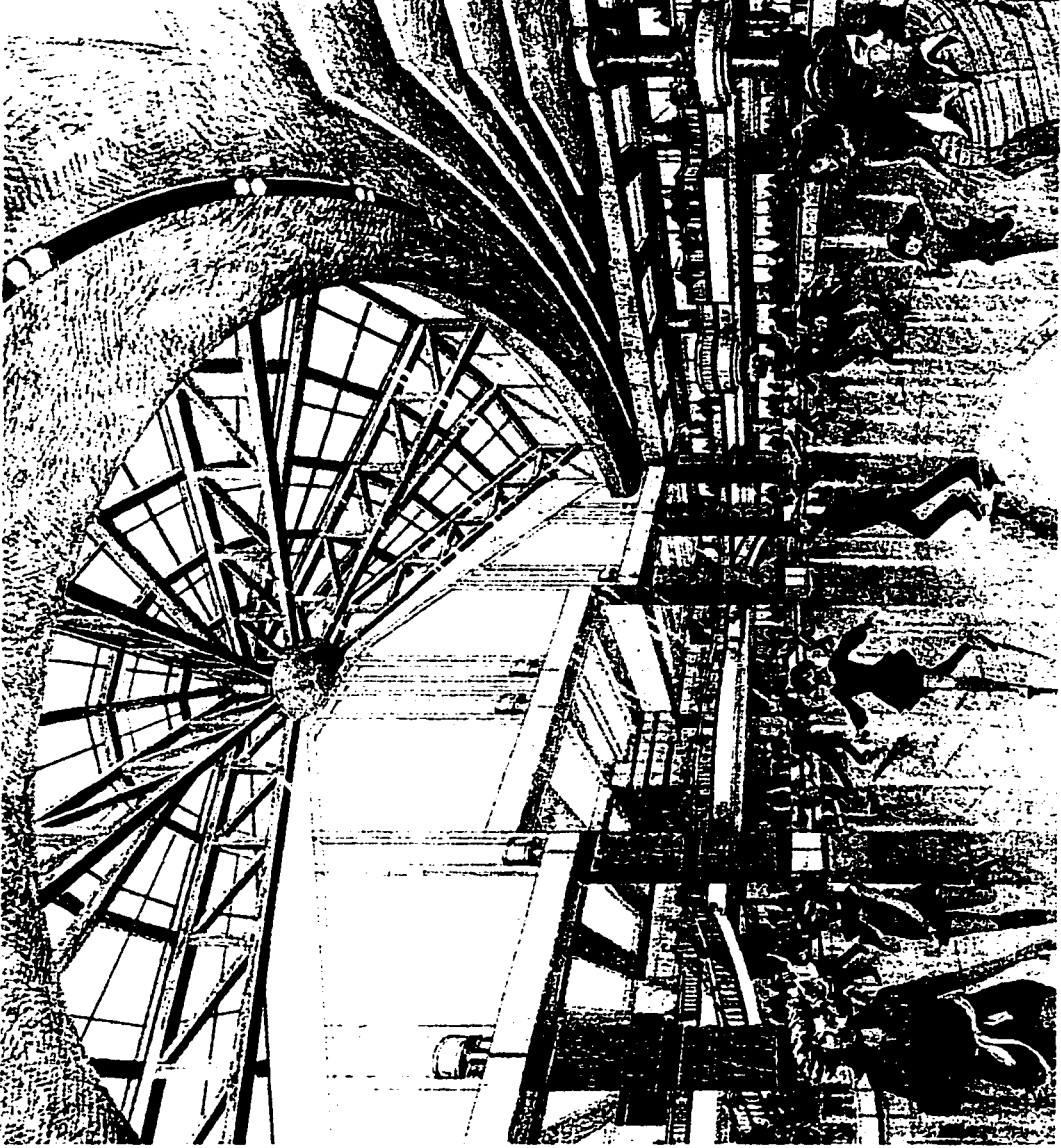

Fig. 93. Interior Perspective. Bell Amphitheatre Skating Rink. Le 1000 de La Gauchetière, Montreal, 1988-92.

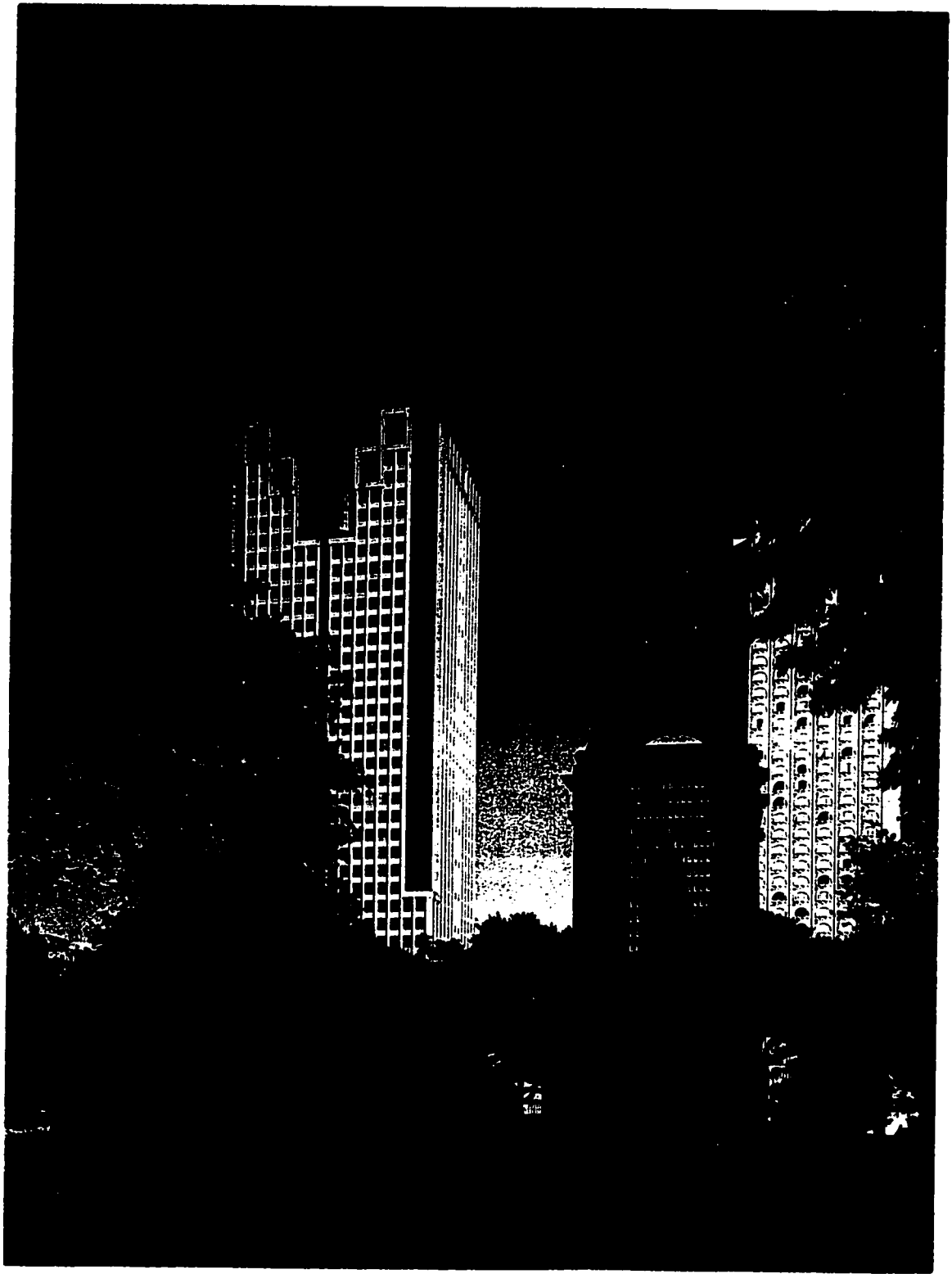

Fig. 94. Dorchester Square View. Le 1000 de La Gauchetière, Montreal.

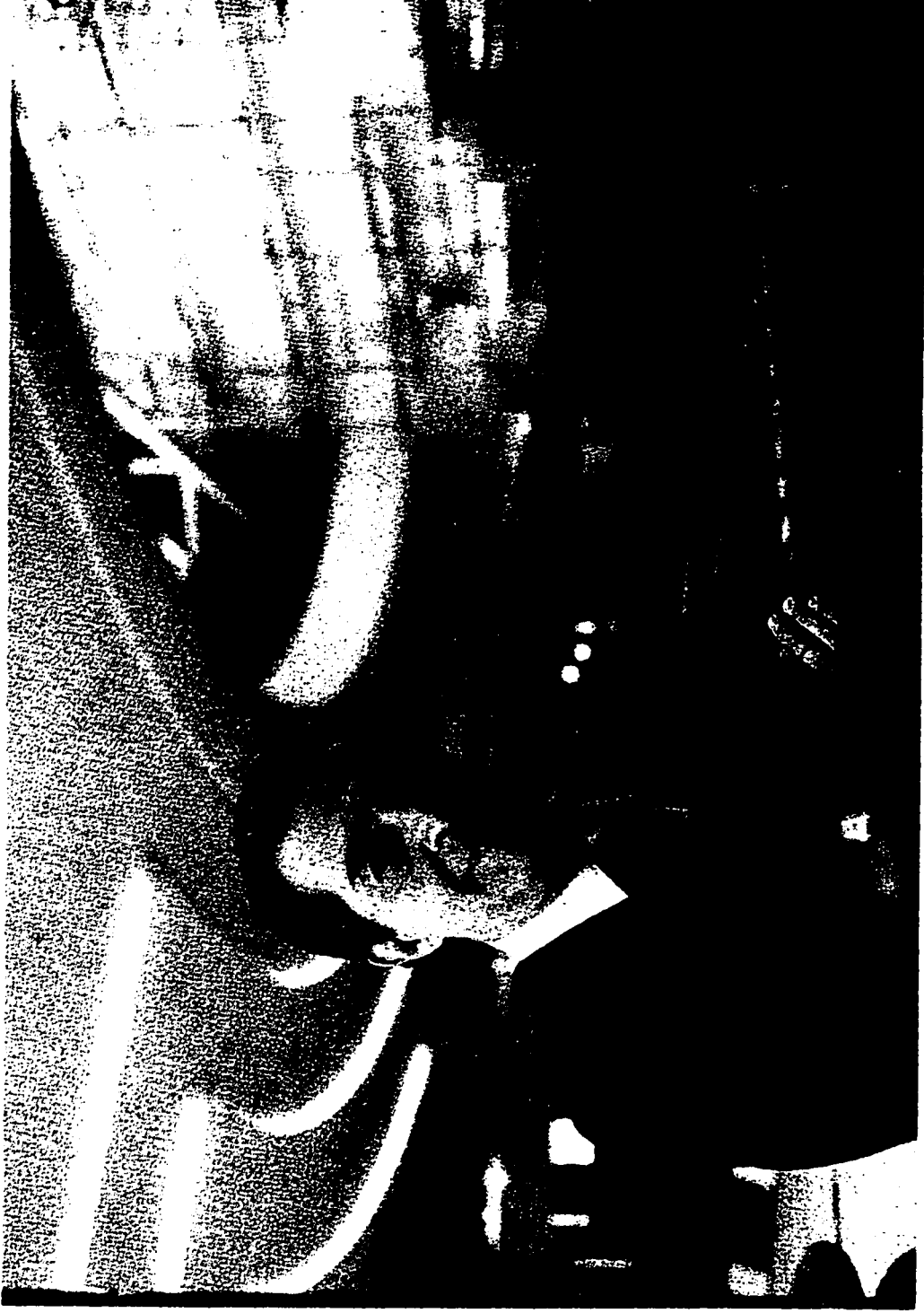

Fig. 95. Dimitri Dimakopoulos in the Bell Amphitheatre. Le 1000 de La Gauchetière, Montreal, 1988-92.

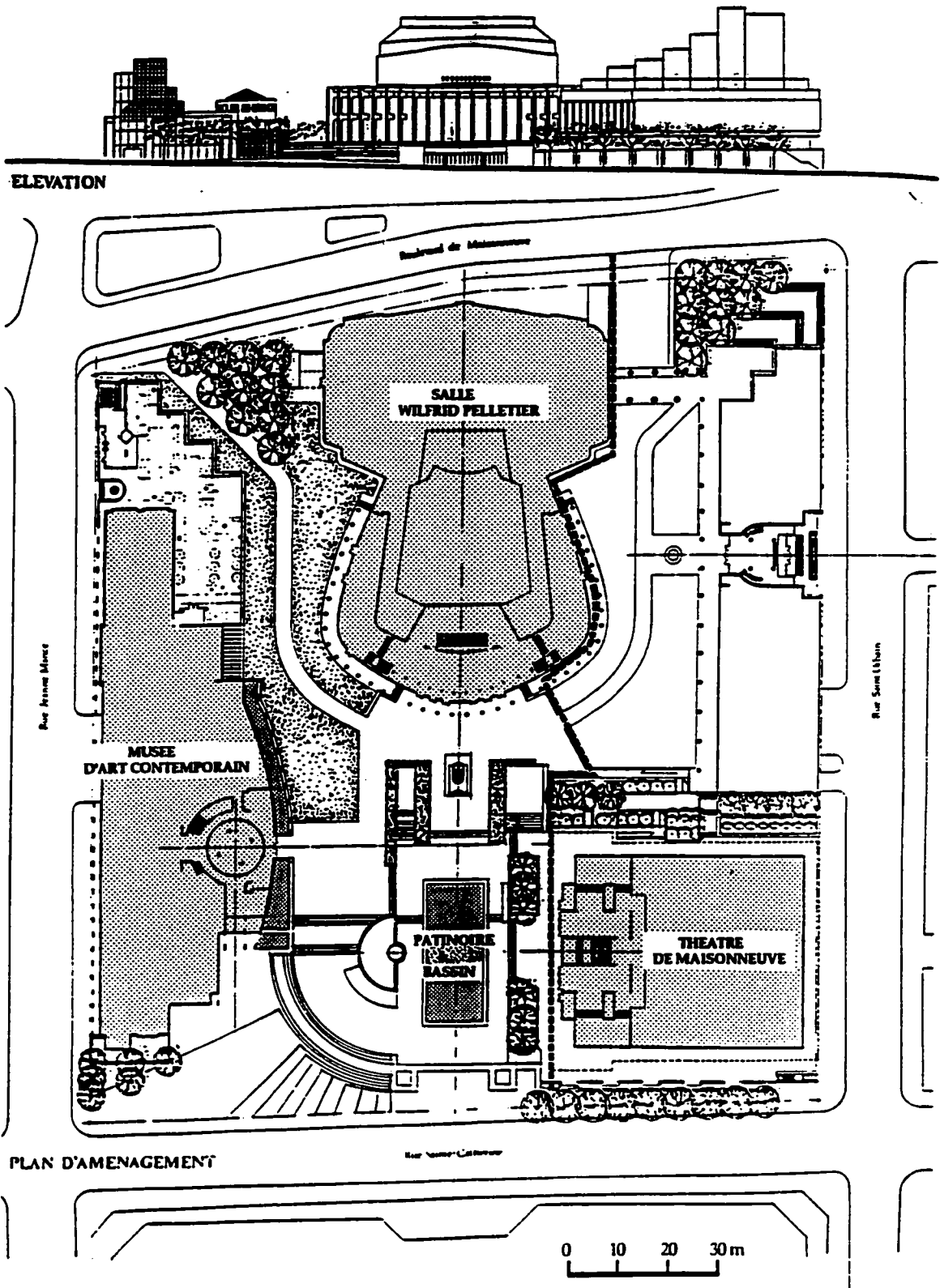

Fig. 96. Site Plan. Place des Arts Quadrilateral Competition Project, 1988.

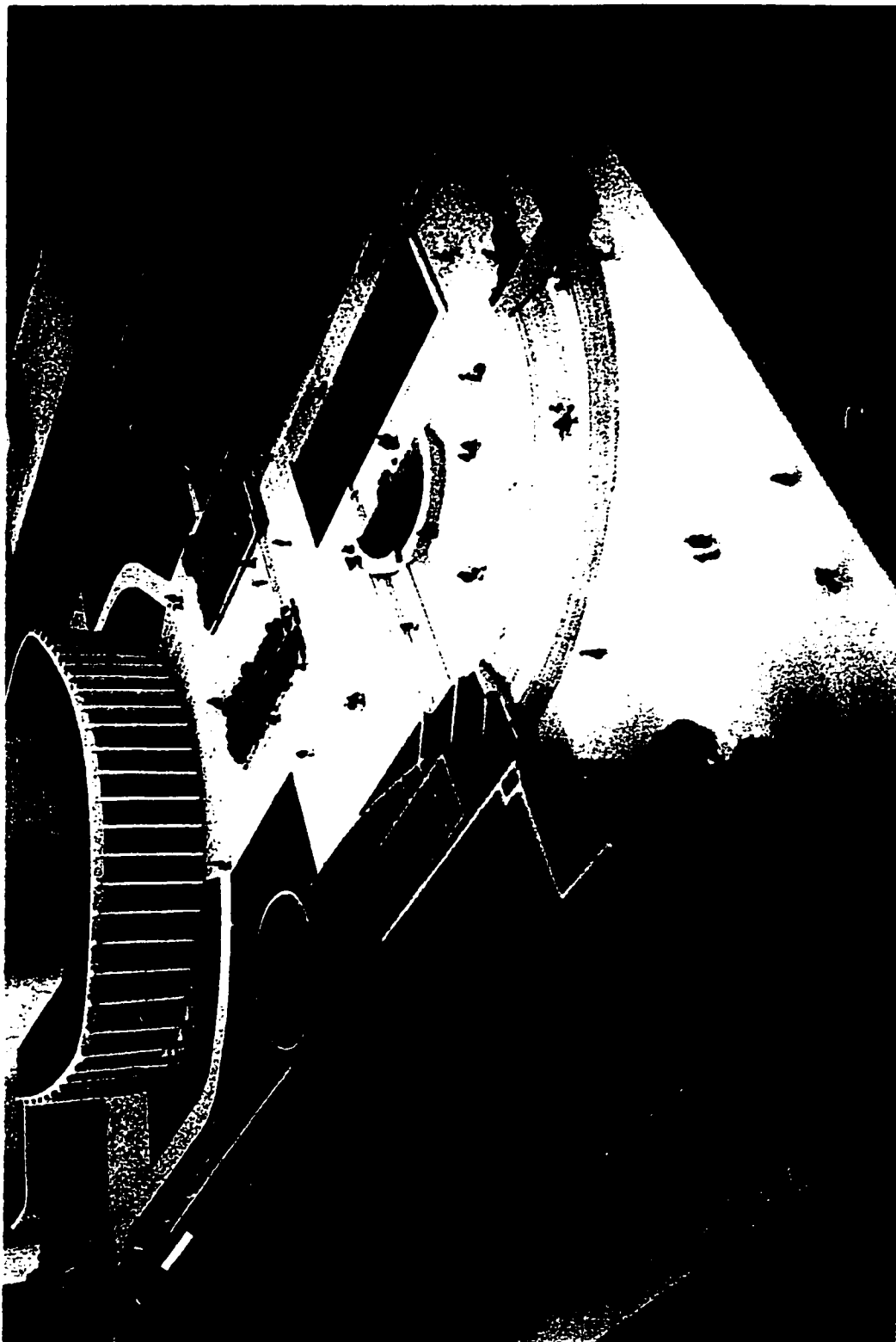

Fig. 97. Final Model. Place des Arts Quadrilateral, Montreal, 1988-93.



Fig. 98. Exterior View on Monumental Stairs. Place des Arts Quadrilateral, Montreal, 1988-93.



Fig. 99. Exterior View on Swimming Pool Pavilion. Apache Residence Expansion, Dorval, 1989-93.

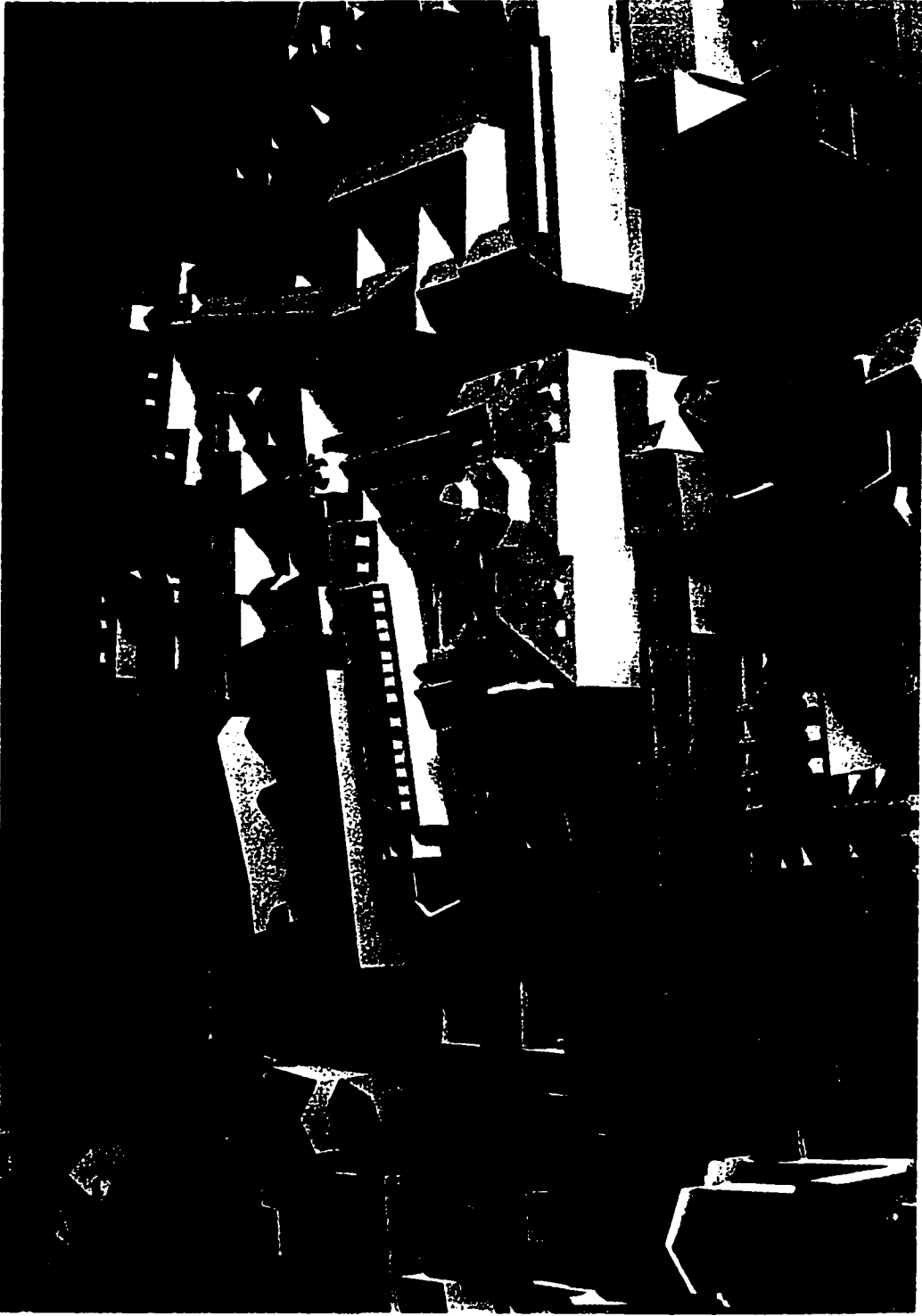

Fig. 100. Model. Hotel Complex Project, Mala Strana, Prague, 1990-91.



## BIBLIOGRAPHY

- Abell, Walter. "Young Canada: Gordon Webber," Canadian Art June-July 1944: 200-1.
- "About the Centre. History of the building." [Http://www.ConfederationCentre.com/history.Html](http://www.ConfederationCentre.com/history.Html) 11/7/00 7 pages.
- Achat Montréal timbres-monnaies inc. Telephone conversation, 31 Oct. 2000.
- Ackerman, James S. Palladio. England: Penguin Books, 1991. 196 pages.
- Acland, James H. "Place Bonaventure and municipal decision." The Canadian Architect Sep. 1967: 45-7.
- "Architecture 1945-1959. The eleven best buildings since the war." The Canadian Architect Oct. 1959: 52-69.
- Affleck/Desbarats/Dimakopoulos/Lebensold/Sise. "Confederation Centre, Charlottetown, Prince Edward Island. Comments by the architects." Journal RAIC Dec. 1964: 20-1.
- Affleck, Raymond T. "Recent Canadian experience in wall design." Architecture Canada Feb. 1969: 51-4.
- Affleck, R. T. "Coordination and organization of the Place Ville Marie project." Journal RAIC Feb. 1963: 61-2
- Affleck, R. T. "Place Bonaventure. The architect's view" Architecture Canada July 1967: 31-9.
- Alexis Nihon (Québec) Inc. One Place Alexis Nihon. Promotional brochure. Montreal: The Alexis Nihon Group, 1987. 10 pages.
- Annual report of the Department of Public Works for the Province of Prince Edward Island for the year that ended March 31st 1963 (until 1967) Charlottetown: Irwing Printing Co. Ltd., 1963 to 1967.
- Archer, Thomas. "Grande Salle completely conquers audience." The Gazette 23 Sep. 1963: 10.
- Architectes en consortium David Boulva Cleve, Dimakopoulos & associés, Gordon Edwards. Centre de recherche en biotechnologie. Document de proposition pour Travaux Publics Canada. Montreal: Architectes en consortium David Boulva Cleve, Dimakopoulos & associés, Gordon Edwards, June 28, 1983. 70 pages.

- Architectes en consortium David Boulva Cleve, Dimakopoulos & associés, Gordon Edwards. Centre de recherche en biotechnologie. Présentation du concept pour Travaux Publics Canada. Montreal: Architectes en consortium David Boulva Cleve, Dimakopoulos & associés, Gordon Edwards, September 1983. 25 pages.
- Architectes en consortium David Boulva Cleve, Dimakopoulos & associés, Gordon Edwards. Institut de recherche en biotechnologie. Présentation du concept pour Travaux Publics Canada. Montreal: Architectes en consortium David Boulva Cleve, Dimakopoulos & associés, Gordon Edwards, October 3, 1983. 16 pages.
- “Au chantier de l’Université du Québec à Montréal les échéanciers et les budgets sont respectés.” Bâtiment Oct. 1977: 18-9.
- “Award. College Montis Regii, Université de Montréal The Canadian Architect, 1969 Yearbook (1970): 54-5.
- “Award. Life Sciences Building, Dalhousie University, Halifax, N.S.” The Canadian Architect, Yearbook 1968 (1969): 54-5.
- Ayre, Robert. “Place des Arts: the artists.” The Canadian Architect Nov. 1963: 62-5.
- Baker, Joe. “Canadian landmarks revisited. 1. Place Ville Marie.” The Canadian Architect March 1994: 40-41.
- “Bank of Canada Head Office, Ottawa.” The Canadian Architect June 1978: 22-25.
- Barott, T. M. “Place des Arts. Garages.” Journal RAIC Nov. 1963: 50.
- Beaulac, Henri. “Place des Arts. La Grande Salle. La décoration.” Architecture-Bâtiment-Construction Jan. 1964: 24-8.
- Beaulieu, Claude. “La Salle de Concert de la Place des Arts.” Journal RAIC Nov. 1963: 38-9.
- Beaupré, Pierre, et al. “Hull 1970-1980: la décennie prodigieuse?” Architecture Québec ARQ #17 (Feb. 1984): 14-27.
- “Beaver Lake Pavilion, Montreal. Architects: Hazen Sise and Guy Desbarats.” The Canadian Architect Dec. 1958: 42-7.
- Bell Canada. Montreal telephone directory (White and Yellow Pages from 1953 to 74).
- Bergeron, Claude. Architecture du XXe siècle au Québec. Montreal: Editions du Méridien, 1989. 271 pages.

- Bervin, George, and France Galarnau. "C'était hier. Un palais et son histoire." Magazine Justice. Vol. V No. 8 Dec. 1983: 4.
- Bibliothèque nationale du Québec. Liste des documents du fonds ADDLS Montreal: Bibliothèque nationale du Québec, 1955-68. 19 pages.
- "Bills for museums will be \$186 million." The Gazette 29 Nov. 1983: B-1.
- "Biographie. Jean-Marie Roy." Architecture Québec. ARQ #36 April 1987: 34.
- "Bio-Mega Centre aid appeal renewed." The Gazette 13 Nov. 1983: D-1.
- Bisson, Pierre-Richard. "J.O. Marchand. Notes biographiques et pré-inventaire de l'oeuvre." Architecture Québec ARQ No. 31 June 1986: 18-21.
- Bisson, Pierre-Richard. "Un monument de classe internationale. La maison-mère de la congrégation Notre-Dame." Architecture Québec ARQ No. 31 June 1986: 14-18.
- Blanchet, S. "Le Palais des congrès: Enfin une réalité." Bâtiment March-April 1983: 20-22.
- Bland, John. Director of the McGill School of Architecture from 1945 to 67. Telephone conversation, 13 Dec. 1999.
- Bland, John. "McGill University School of Architecture." Journal RAIC May 1949: 142-3.
- Bland, John. "Place des Arts: A critical appraisal." The Canadian Architect Nov. 1963: 60-1.
- Bland, John. "Place Ville Marie. Appraisal." Journal RAIC Feb. 1963: 47-50.
- Bland, John. "Ray Affleck and the McGill School of Architecture." Architecture Québec ARQ No.34 Dec. 1986: 10-11.
- Blostein, Maier. McGill graduate in engineering, 1954. Telephone conversation. 7 Dec. 1999.
- Boddy, Trevor. "Calgary's Plus Fifteen." The Architectural Review 999 (May 1980): 310-312.
- Boddy, Trevor. "Critique: Architecture on the fast track." The Canadian Architect June 1988: 44-49
- Boggs, Jean Sutherland. "Twelve proposals for the National Gallery of Canada and for the National Museum of Man. Introduction." Section A Supplement Aug. 1984: 3.

- Bolt, Beranek & Newman Inc. "Acoustical design of the Grande Salle." Journal RAIC Nov. 1963: 49-50.
- Bonhomme, Jean-Pierre. "La phase II de l'UQAM: un design correct sans plus." La Presse 25 Sept. 1990: B7.
- Bonhomme, Jean-Pierre. "La Place des Arts aura sa vraie place urbaine." La Presse 5 May 1991: B 7.
- Bonhomme, Jean-Pierre. "L'aventure complexe du "1000 de la Gauchetière." La Presse 12 Aug. 1990: E 6.
- Bonhomme, Jean-Pierre. Le Comité conseil de l'arrondissement Centre rejette le projet de l'UQAM." La Presse 19 Jan. 1990: A 4.
- Bonhomme, Jean-Pierre. "L'UQAM ne se démarque pas beaucoup d'un immeuble à bureaux." La Presse 8 Oct. 1989: C3.
- Bonhomme, Jean-Pierre. "L'UQAM se déplace vers l'ouest pour relier ses deux campus." La Presse 22 April 1991: A 4.
- Bonhomme, Jean-Pierre. "Un "campanile" pour la cathédrale catholique" La Presse 22 Jan. 1989: C 3.
- Boulanger, Robert. Les Guides Bleus. Grèce. Paris: Librairie Hachette, 1967. 1014 pages.
- Bressani, Martin. "Critique: the impossible wave train." The Canadian Architect Nov. 1989: 23-31.
- Brett, J. E. "Structural design of Place Ville Marie." Journal RAIC Feb. 1963: 77-81.
- "Brief notes on the exhibition. Acknowledgements." 1976 Exhibition of the Greek Pavilion at Terre des Hommes in Montreal. Promotional brochure. Montreal: Dimitri Dimakopoulos & Partners Architects and Jacques Guillon Designers Inc., 1976.
- Brisebois, Marcel. "L'abandon de la solitude. 1992, la relocalisation du Musée d'art contemporain de Montréal en perspective." Musées Vol. 12 No.4 Dec. 1990: 24-29.
- Brisebois, Marcel. "Le Musée d'art contemporain," Vie des Arts No.145 (Winter 1991-92): 16-18.
- Brisson, Jean-Claude, and Jacques Poulin. Palais de justice. Fiche technique. Quebec: Société immobilière du Québec, 18 Oct. 1993. 5 pages.

- Brown, Craig, et al. Histoire générale du Canada. Montreal: Editions du Boréal, 1988.  
702 pages.
- Brown, Douglas B., Chairman. "Theatre building. A discussion." Journal RAIC Nov. 1963: 51-4.
- Canada's new capital - La nouvelle capitale du Canada. Ottawa-Hull: National Capital Commission, 1970's: 14 pages.
- "Canadian Museum of Civilization, Hull, Quebec." The Canadian Architect Nov. 1989: 18-22.
- Caragianis, Kimon. Associate architect with ARCOP on the Greek Orthodox Cathedral commission. Telephone conversation, 9 Oct. 2000.
- Cardinal, Douglas. "National Museum of Man." Architecture Québec ARQ No. 17 Feb. 1984: 28-29.
- Carin, Michael. "Dimitri Dimakopoulos. Take a downtown walking tour with a leading architect". Montreal Business Magazine June 1992: 30-32.
- Castro, M. "L'Edifice La Laurentienne." Bâtiment May-June 1985: 12-13.
- Castro, Marc. "PVM: un renouveau." Bâtiment Nov.-Dec. 1986: 16-17.
- "Celebrated architect designed many of Montreal's downtown landmarks. Montreal Obituary". The Gazette 9 Nov. 1995: A 5.
- "Centre des arts et de la culture, St-Jean, Terre-Neuve." Architecture - Bâtiment - Construction Jan. 1967: 11-13.
- "Centre des Pères de la Confédération Charlottetown." Architecture - Bâtiment - Construction Dec. 1964: 32-40.
- "Centre National des Arts." Architecture Concept Dec. 1969: 22-31.
- "Centre National des Arts. Ottawa." Architecture - Bâtiment - Construction Jan. 1966: 25-9.
- Chalvin, Solange. "Elégance, son et lumière samedi à la Place des Arts." Le Devoir 23 Sep. 1963: 7.
- Choueke, Esmond. "Montreal campus project designed as a mixed-use city core university." Canadian Building March 1977: 23-4.
- Cindic Consultants Ltd. Jing An Hilton Hotel Shanghai. Conceptual design scheme.

- Developer: Cindic Hotel Investment Co. Ltd. Hong Kong: Cindic Consultants Ltd, Sept. 6, 1984.
- “Citation: Place d’Accueil, Hull, Québec.” The Canadian Architect Jan. 1977: 38-9.
- Cité Concordia. Montreal: Concordia Estates Limited, 1970. Presentation brochure.
- “City of Ottawa Police Building Competition.” Journal RAIC March 1955: 91-4.
- Cobb, Henry N. “Some notes on the design of Place Ville Marie.” Journal RAIC Feb. 1963: 54-7.
- Collins, Peter. “Orthodoxy.” Journal RAIC Dec. 1962: 65-8.
- Collymore, Peter, “New atria of Canada.” Architectural Review No. 999 May 1980: 273-285.
- “Comment. Expo ’70 Competition.” The Canadian Architect Aug. 1967: 29-38.
- Communauté hellénique de Montréal. Brief history of the Hellenic community of Montreal Montreal: Communauté hellénique de Montréal, 1997. 8 pages.
- “Competition. Fathers of Confederation Memorial Building for Charlottetown, PEI.” The Canadian Architect March 1962: 57-63.
- “Complexe A. Nihon: la structure de la nouvelle tour à bureaux a été complétée.” Bâtiment Jul.-Aug. 1985: 10.
- “Concordia named construction manager for \$41.6-million federal project in Hull, Quebec.” Canadian Building May 1973: 41.
- Concorde West. Architectural. Montreal: Dimitri Dimakopoulos & Partners, 1972. Presentation brochure.
- “Confederation Centre, Charlottetown, Prince Edward Island.” Journal RAIC Dec. 1964: 19-64.
- “Construction hôtelière: Montréal au premier rang. Un édifice dont Montréal sera fière”. Bâtiment Jan. 1973: 11-12.
- Consultas Inc. Université du Québec. Rapport sur le choix d’un site en vue de l’implantation de l’Université du Québec à Montréal. Montreal: Consultas Inc., 1971: 37 pages.
- D’Amour, Henri-Julien “Hull au coeur de la capitale du Canada.” Architecture Québec ARQ #17 (Feb. 1984): 10-12.

Data Sheets - New buildings in downtown Hull. Ottawa - Hull: National Capital Commission, 1979: 14 pages.

Davenport, William Wyatt. Athènes. Les Grandes Cités. Amsterdam: Time-Life International, 1978, 200 pages.

“Début des travaux au Palais des congrès.” Le Devoir 19 Oct. 1979: 3.

“Decade.” The Canadian Architect Nov. 1969: 34-46.

Delean, Paul. “Levesque to open \$87-million palais.” The Gazette 27 May 1983: A1-2.

Desbarats, Guy. Former partner in Affleck Desbarats Dimakopoulos Lebensold Michaud Sise Architects. Telephone conversation, 7 Apr. 2000.

Desbarats, Guy. Answers to questionnaire written on 30 April 2000.

Desbarats, Guy. First interview in Georgeville, 25 Sept. 2000.

Desbarats, Guy. Second interview in Georgeville. 2 Oct. 2000.

Desbarats, Guy. Three views on architecture Georgeville: manuscript, 2000.

de Silva, Walter F. “Fathers of Confederation Memorial Buildings, Charlottetown. Critique.” The Canadian Architect Nov. 1964: 50-1.

Dimakopoulos & Partners. Dimakopoulos & Partners. Architecture and urban design. Promotional pamphlet. Montreal: Dimakopoulos & Partners, c.1978. 6 pages.

Dimakopoulos & Partners and Gordon Edwards Architects. “Twelve Proposals for the National Gallery of Canada and for the National Museum of Man. Dimakopoulos & Partners and Gordon Edwards Architects.” Section A Supplement Aug. 1984: 32-34.

Dimakopoulos, Irene. Dimitri’s older daughter. Answers to first questionnaire written on 17 Dec. 1999.

Dimakopoulos, Irene. Answers to second questionnaire written on 4 May 2000.

Dimakopoulos, Marina. Dimitri’s younger daughter. Answers to first questionnaire written on 6 Jan. 2000.

1890-1990. Un siècle à bâtir 1990-2090. Montreal: Corporation Architecture 1990, 1990. 96 pages.

“Drive-in restaurant, Montreal.” Journal RAIC May 1958: 183.

DuBois, Macy. “Bank of Canada: a contribution to office design.” The Canadian Architect June 1978: 26-37.

- DuBois, Macy. "National Arts Centre, Ottawa. Critique." The Canadian Architect July 1969: 44-8.
- Dupaul, Richard. "Bio-Méga Inc.: des retombées avantageuses attendues de la biotechnologie." Finance Vol. 6 No. 43 19 Aug. 1985: 25.
- DWA. Dimakopoulos Wigglesworth architectes. Promotional brochure and annexed sheets. Montreal: Dimakopoulos Wigglesworth architectes, 1995.
- Economou, Constantine. McGill graduate. Letter to the author. 31 Jan. 2000.
- Edifice La Laurentienne. Caractéristiques architecturales. Montreal: Edifice La Laurentienne, 1984: 2 pages.
- Edifice La Laurentienne. Caractéristiques générales du bâtiment. Montreal: Edifice La Laurentienne, 1984: 2 pages.
- Edifice La Laurentienne. Début des travaux de l'Edifice La Laurentienne à Montréal. Communiqué de presse. Montreal: Edifice La Laurentienne, 15 Feb. 1984: 2 pages.
- Edifice La Laurentienne. L'équipe. Montreal: Edifice La Laurentienne, 1984: 1 page.
- Edwards, Gordon. McGill graduate in architecture, 1954. Telephone conversation, 8 Dec. 1999.
- Ellwood, Michael. "Place Ville Marie. Offices for the Aluminum Limited Group of Companies." Journal RAIC Feb. 1963: 67-74.
- Enchin, Harvey. "Contract gives architect hope." The Gazette 29 Aug. 1979.
- En présence du maire de Montréal, M. Jean Doré. Inauguration de trois nouveaux pavillons de l'UQAM. Communiqué. Montreal: UQAM, 5 June 1992. 3 pages.
- "Entrepôt de Norman Wade Co. Ltd. à Pointe-Claire." Architecture Bâtiment - Construction June 1962: 32-5.
- "Expo '70, Osaka." Architecture Canada Aug. 1967: 45-7.
- "Fathers of Confederation Memorial Building Charlottetown PEI. Report of jury." Journal RAIC Feb. 1962: 31-41.
- "Fathers of Confederation Memorial Building, Charlottetown." Journal RAIC May 1964: 46.
- "Fathers of Confederation Memorial Buildings, Charlottetown." The Canadian Architect Nov. 1964: 41-59.



- Favreau, Marianne. "La Ville se livre-t-elle à des "tours" de passe-passe?" La Presse 22 Sept. 1988: A 10.
- Favreau, Marianne. "Le futur gratte-ciel, rue de La Gauchetière, sera terminé dans les délais prévus." La Presse 1st Nov. 1989: A 8.
- Favreau, Marianne. "Pavillon à corriger." La Presse 21 Jan. 1990: B 5.
- Favreau, Marianne. "Une manne pour les bureaux d'études." La Presse 29 Jan. 1989.
- Ferrabee, James. "For the Place des Arts... Glittering opening night." The Gazette 23 Sep. 1963: 9.
- Fiore, Francine. "Tours à bureaux: les impératifs de la mode." Bâtiment March-April 1989: 21-24.
- "Flash sur l'UQAM." Perspective. La Presse Vol.21 No. 35 1er Sept. 1979: 11.
- Francisco, Rosemary. Public representative for Place Ville-Marie. Telephone conversation. 11 Oct. 2000.
- Freedman, Adele. "Architectural contest for museum, gallery. Strictly private affair." The Globe and Mail 5 Jan. 1983: 1.
- Freedman, Adele. "\$186-million projects unveiled." The Globe and Mail 29 Nov. 1983: 17.
- Gauthier, Paul, et al. "Jean-Marie Roy" Architecture Québec ARQ No.36 (April 1987): 21, 26-7, 34.
- Gérin-Lajoie, Guy. McGill graduate in architecture. 1956. Telephone Conversation. 19 Dec. 1999.
- Giddings, Ken. "Better precast concrete." Journal RAIC Aug. 1963: 34-8.
- Gingras, Claude, et al. "Le 30e anniversaire de la Place des Arts. Cahier spécial". La Presse 23 Oct. 1993: 1-16.
- Giovannini, Joseph. "Urban diplomat." Architectural Record (May 1993): 74-79.
- Godfrey, Stephen. "Sad portrait of a second-class citizen. The National Museum is to have a new home - It needs one." The Globe and Mail 27 Aug. 1983: E-13.
- Goldschmidt, Nicholas. "The musician's view." The Canadian Architect Jan. 1960: 58-9.
- Gosselin-Geoffrion, Hélène. "Hôtel Le Concorde, Québec." Architecture Concept Nov. /

- Dec. 1974: 14-18, 43.
- Grant, Alastair. "The National Arts Centre." Architecture Canada May 1969: 35-6.
- Grant, Alastair. "National Arts Centre. Planning and technical data." Architecture Canada May 1969: 38-9.
- Gravel, Pierre. "Il aura fallu une intervention humaine pour déclencher l'alarme à la Place Alexis-Nihon." La Presse 17 March 1987: A-3.
- Gravel, Pierre. "Le feu de la Place Alexis-Nihon devrait servir de leçon, disent les assureurs." La Presse 15 March 1987: B-1.
- Gravel, Pierre. "Les pompiers estimaient pouvoir faire face à un tel incendie." La Presse 19 March 1987: A-3.
- "Greek Orthodox Cathedral, Montreal." The Canadian Architect Aug. 1960: 42.
- "Greek Orthodox Cathedral, Montreal." The Canadian Architect Nov. 1961: 17-26.
- Grenier, Cécile and Joshua Wolfe. Explorer Montréal. 2nd Ed. Montréal: Editions Libre Expression, 1990: 341 pages.
- Harvey, M.J. "Feedback: Dalhousie Life Sciences Centre." The Canadian Architect Feb. 1974: 34-6.
- Hartley, Nadia. Lydia Chabaline's sister. Letter to the author. 3 Jan. 2000.
- Hayes, Bob. "Giant Place Ville Marie opened." The Gazette 14 Sep. 1962: 15.
- Hénault, Odile. "A Montréal. Trois musées. Bricolage ostentation sobriété." Vie des Arts No. 145 Winter 1991-92: 14-18.
- Hicks, Laureen. "Place des Arts opening is colorful and glittering spectacle. Glamorous formality overshadows disturbances." The Montreal Star 23 Sep. 1963: 14.
- Honour, Hugh & John Fleming. The Visual Arts. A History. New Jersey: Prentice Hall. 1995. 864 pages.
- "Hotel. Hotel, Quebec City." The Canadian Architect Nov. 1969: 62.
- Hull. Hull-Ottawa: National Capital Commission, 1974: 18 pages.
- "Hull. L'impact du programme fédéral de construction d'édifices à bureaux." Bâtiment Aug. 1974: 17-18.
- "Hull no longer Ottawa's "poor cousin"!" Canadian Building Dec. 1973: 18.
- Inauguration du pavillon de l'éducation. Communiqué. Montreal: UQAM, 13 Oct. 1993.

- 3 pages.
- “Inauguration officielle de la “Place de la Justice” de Québec.” Journal Constructo 1st Nov. 1983: 1.
- “Institut de biotechnologie: fin des travaux prévue pour mars.” Bâtiment March-April 1985: 7.
- Jacques, Lucien. “La structure de la Grande Salle.” Journal RAIC Nov. 1963: 42-...
- Janson, H. W. and Anthony E. Janson. History of Art. 5th Ed. revised. New York: Harry N. Abrams Inc., 1997. 1000 pages.
- Jencks, Charles. The Language of Post-Modernism. 6th rev. & enl. ed. London: Academy Editions, 1991. 204 pages.
- Jencks, Charles. Post-Modern Classicism. The New Synthesis. London: Architectural Design, 1980. 144 pages.
- J.L.P. et associés, Dimakopoulos & associés architectes. Dawson College. Atwater Campus. Phase III. Montreal: J.L.P. et associés, Dimakopoulos & associés architectes, September 27, 1988. 18 pages.
- Kelly, Norma. “Place des Arts. Design stresses comfort.” The Montreal Star 17 Sep. 1963:10.
- Knott, Leonard L. La Place Montreal: Rolph Clark Stone Benallack Limited, 1962. 128 pages.
- Kutshke, Caroline. “Renovating Dawson College no easy feat: architect.” The Westmount Examiner 29 Sept. 1994: 12.
- Labatt. 26 semaines à / weeks at Expo 67 Montreal: Labatt, 1967. 64 pages.
- Lachaud, Annie. “Michel Saint-Cyr: “Le 1000 de La Gauchetière sera le nouveau carrefour de Montréal.” Bâtiment Nov.-Dec. 1989: 14-15.
- La Cité. Des vacances à vie dans une maison de cèdre, aux portes de Montréal. Promotional brochure. La Prairie, Quebec: Gulf Development of Laprairie Inc., c.1978: 16 pages.
- “La gare modale projetée...” Le Soleil 29 Sept. 1983: B-6.
- “La Laurentienne: Un investissement de 75 millions de dollars.” Bâtiment March-April 1984: 9.

- Lamarche, Dominique. "Bio-Méga. Au-delà des dunes, quelque part où n'importe où veut dire ailleurs qu'ici..." Décor No.161 May 1987: 89-94.
- Lamoureux, Marie-Claude. Order of Architects of Quebec. Telephone conversation, 8 Dec. 1999.
- Lamy, Raymond, Project Manager for Public Works Canada. Telephone conversation, Dec. 4, 2000.
- Lannois, Philippe. A Athènes. France: Hachette, 1981, 221 pages.
- Lapierre, Vallier. "Bio-Méga compte synthétiser de nouveaux médicaments d'ici deux à trois ans." Les Affaires Vol. 63 No. 6 9 Feb. 1991: C-18, 19.
- "La "Place de la Justice": Un contrat réalisé à l'intérieur des coûts et des échéanciers prévus. Autres contrats accordés." Journal Constructo 1st Nov. 1983: 20.
- "La Place Ville-Marie officiellement ouverte." Le Devoir 14 Sep. 1962: 3.
- Larivière, Joseph Ernest. McGill graduate in architecture, 1953. Telephone conversation, Dec. 1999.
- Larose Gilles-L. Partner in Larose Laliberté Petrucci. Telephone conversation. !6 Jan. 2001.
- Lasserre, Fred. "A Canadian looks at his profession." Canadian Art Oct.-Nov. 1945 24-9.
- "L' avant-première. Le Centre National des Arts, Ottawa." Architecture - Bâtiment - Construction Dec. 1968: 11-17.
- Laurier, Marie. "La salle Wilfrid-Pelletier améliore tant son esthétique que son acoustique." La Presse 19 Aug. 1991: 11.
- Laurier, Marie. "Connaissez-vous la place de tout le monde." Le Devoir 28 May 1993: A 3.
- "Lavalin pourrait ne jamais déménager dans son nouveau siège social." Les Affaires 15 Sept. 1990: B 2.
- "Lavalin songe à réduire ses investissements immobiliers." Les Affaires 29 Sept. 1990: 75.
- Lavoie, Denis. "20 millions \$ ont été investis au théâtre Saint-Denis et à la salle Wilfrid-Pelletier". La Presse 17 Feb. 1990: D 4.

- Lazarus, Charles. "Place Ville Marie opened officially." The Montreal Star 14 Sep. 1962 Section II: 1.
- Lazarus, Charles. "Place Ville Marie to get addition within 12 months." The Montreal Star 13 Sep. 1962: 1.
- Lazosky, Daniel. "Place Bonaventure: design build." The Canadian Architect Sep. 1967: 59-64.
- Lazosky, Daniel. Telephone conversation, 13 Nov. 2000.
- Lebensold, D. F., "La Grande Salle / Place des Arts." Journal RAIC Nov. 1963: 32-7.
- Lebensold, Fred. "Place des Arts, Montreal, P.Q." The Canadian Architect Nov. 1963: 48-59.
- Lebensold, D. F. "Theatre: A need for dialogue." The Canadian Architect Aug. 1966: 51-3.
- Leblanc, Gérald. "Les Grecs dans la région de Montréal. Dimitri Dimakopoulos arrivé en 1948." La Presse. 14 Sep. 1991.
- Le Blanc, Yvon. "Centre de Confédération. Critique par Yvon Le Blanc." Journal RAIC Dec 1964: 38-9.
- "L'échéancier est respecté pour le Palais des congrès de Montréal et le Palais de Justice de Québec". Bâtiment March 1980: 18-19.
- "Le concours du musée de la Civilisation." Architecture Québec ARQ Oct. 1981: 27-29.
- Legault, Céline, et al. Place de la Justice de Québec. Quebec: Gouvernement du Québec, Ministère de la Justice, 1983. 59 pages.
- Lehrman, Jonas. "Place Ville Marie. Critique two." The Canadian Architect Feb. 1963: 63-4.
- Lemieux, Louise. "Palais de justice: dans cinq jours le déménagement." Le Soleil 24 Sept. 1983: C-9.
- Le 1000 De La Gauchetière. A new vision of Montreal. Promotional brochure. Montreal: Brookfield Development Corporation, 1992. 22 pages.
- "Le 1000 de La Gauchetière déjà érigé." Bâtiment May-June 1991: 8.
- "Le 1000 La Gauchetière: Ce sera de l'acier." Bâtiment Feb. 1980: 10.
- Le Ministère des Travaux Publics. Le complexe scientifique du Québec. Cahiers 1 et

2. Québec: Thérien Frères (1960) Limitée, Imprimeurs, 1969.
- “Le ministre des Travaux publics et de l’Approvisionnement...” Le Soleil 28 Oct. 1983: A-10.
- “Le miracle de la tour infernale.” Revue Commerce 89e Année No. 1, Jan. 1987: 18.
- Lemire, Robert and Monique Trépanier. Inventory of buildings constructed between 1919 and 1959 in old Montreal and Saint-Georges and Saint-André wards. Ottawa: Ministry of Supplies and Services, 1981.
- “Les nouvelles tours du centre-ville s’adaptent mieux à leur environnement.” Les Affaires 13 April 1991: B 8.
- Lepage, Danielle, and André Steenhaut. Communiqué. Un appel à tous les architectes du Québec. Réseau Telbec Code 01. Quebec: Gouvernement du Québec; Ministère des Travaux publics et de l’Approvisionnement, 29 Nov. 1983. 4 pages.
- Lepage, Jocelyne. “Trente ans plus tard, les Montréalais ont leur place des uns et des autres!” La Presse 28 May 1993: C 1.
- “Le Palais des congrès: une course contre la montre.” La Presse 7 April 1983: A1-2.
- Le prochain Palais de Justice de Québec. Quebec: Gouvernement du Québec; Ministère des Travaux publics et de l’Approvisionnement, 1979: 8 pages.
- “Le projet de Palais de Justice de Québec...” Bâtiment Oct. 1979: 7.
- “Les nominations 1985. Dimitri Dimakopoulos chevalier (1985).” [Http:ééwww.cex.Gouv.qc.ca/Ordre/86/86.](http://www.cex.gouv.qc.ca/Ordre/86/86)
- ““Life Sciences Building, Dalhousie University, Halifax, N.S.” The Canadian Architect Feb.1974: 29-36.
- “L’important n’est pas d’être le plus gros, mais d’avoir une identification propre et distinctive.” Les Affaires 26 Aug. 1989: 41.
- Lincourt, Michel. “Centre National des Arts. Commentaires.” Architecture Concept Dec. 1969: 23-6.
- Loews Le Concorde, Place Montcalm, Québec, Canada. Québec: Loews Le Concorde, 1974. Promotional brochure.
- Lord, Dave. “\$5 million to rejuvenate Lachine Canal.” The Montreal Star 28 June 1977: A-2.

- “L’UQAM renaît.” Le Devoir 15 Sept. 1979: 1.
- “L’UQAM: un campus très spécial au coeur de Montréal.” Bâtiment March 1975: 7-10.
- MacKinnon, Frank. Honour the founders! Enjoy the arts! Charlottetown: Fathers of Confederation Buildings Trust, 1990. 68 pages.
- Malter, Fran. “Plaza’s owners are part of a secretive real-estate empire.” The Gazette 1st Nov. 1986: G-1.
- Marcoux, Alain J. “From Post-Modernism to Neo-Stylism: analysis of stylistic developments in late 20th century architecture.” Non-published essay for Concordia University, March 2000. 30 pages.
- Marcoux, Alain J. “From Pre-Modernism to Post-Modernism: analysis of stylistic developments in early 20th century architecture.” Non-published essay for Concordia University, March 2000, 35 pages.
- Marcoux, Alain J. “Persistence of Classicism in Postmodern Architecture.” Non-published essay for Concordia University, April 1998. 17 pages.
- Marcoux, Alain J. “Précisions sur le Brutalisme (1950-1970).” Le Journal d’Outremont Dec. 1995: 26.
- Marcoux, Alain J. “Précisions sur le Minimalisme (c.1970).” Le Journal d’Outremont Feb. 1996: 22.
- Marcoux, Alain J. “Précisions sur le Style Miesien (1939-1973).” Le Journal d’Outremont Oct. 1995: 21.
- Marcoux, Alain J. “Précisions sur le Post-Modernisme.” Non-published article for Le Journal d’Outremont April 1996.
- Marcoux, Alain J. Styles et mouvements architecturaux du dix-neuvième et vingtième siècles Montreal: incomplete manuscript, 1992-2002.
- Marcoux, Alain, ministre, et al. Musée d’art contemporain, Montréal. Esquisses soumises au concours d’architecture. Quebec: Gouvernement du Québec, August 1984.
- “Massey Medals 1964.” Journal RAIC Nov. 1964: 34-134.
- Marsan, Jean-Claude. Montréal en évolution sec. ed. (Laval: Editions du Méridien, Architecture, 1994). 418-9.

- “Massey Medals 1970.” Architecture Canada 12 Oct.1970.
- Matthews, Grace. McGill friend of Dimitri Dimakopoulos. Telephone conversation, 8 Dec 1999. Answers to questionnaire written on 17 Jan. 2000.
- Matthews, Ronald. McGill graduate in architecture, 1955. Telephone conversation, 9 Dec. 1999.
- McDougall, Anne. “John Bland and the McGill School of Architecture.” The Canadian Architect March 1988: 33-37.
- McLean, Eric. “Opening of Place des Arts. Our wonderful new hall!” The Montreal Star 23 Sep. 1963: 10.
- “McGill University. University Library. R.T. Affleck.” Journal RAIC May 1947: 164.
- McGill University. Annual convocation. Wednesday, 25th May, 1955 at 10:00 A.M. Montreal: McGill University, 1955. 46 pages.
- McGill University. McGill University Calendar (from 1948-49 to 1958-59). Montreal: McGill University Press, yearly publications, from 1948 to 1958.
- McGill University. Old McGill’ 53. Volume 56. Montreal:McGill University Press, 1953.
- McGill University. Old McGill’ 54. Volume 57. Montreal:McGill University Press, 1954.
- McGill University. Old McGill’ 55. Volume 58. Montreal McGill University Press, 1955.
- McGill University. Old McGill’ 56. Volume 59. Montreal McGill University Press, 1956.
- McGill University. Old McGill’ 58. Volume 61.Montreal McGill University Press, 1957.
- Ménard,André. Architectures du musée. Competition projects exhibition brochure. Montreal: Musée d’art contemporain de Montréal, 1st July - 16 Sept. 1984.
- Menkès, René. McGill graduate in architecture, 1955. Telephone conversation, 15 Dec. 1999.
- Michelin. Guide de tourisme Michelin Canada. Clermont-Ferrand, France: Michelin et Cie, propriétaires éditeurs, 1994. 252 pages.
- Miller, Jerry. Architect formerly with ARCOP (1959-63). Telephone conversation, Oct. 2000.
- Montpas, Denise. “Aux marches du palais.” Magazine Justice Vol.5 No.8 Dec. 1983: 26-31.
- Montpetit, Caroline. “Chagnon injecte 19 millions dans le collège Dawson.” Le Devoir



- 7 Aug. 1994: A 5.
- “Montreal museum to be relocated.” The Globe and Mail 1st Oct. 1983: Entertainment 5.
- “Montreal’s University of Quebec plans \$90 million two-phase project.” Canada Building Feb. 1975: 8.
- “Montreal’s hotel - building explosion: 4,000 new rooms before ’76 Olympics.” Canadian Building Dec. 1973: 14.
- “Montreal’s \$250 million Cité Concordia poised for early construction start.” Canadian Building Dec. 1973: 19.
- Morisset, Paul. “La trinité des musées.” L’Actualité Vol.12 No. 3. March 1987: 60-8.
- Murray, Irena and Norbert Schoenauer ed. John Bland at Eighty. A Tribute. Montreal: McGill University, 1991. 102 pages.
- Murray, James A., John C. Parkin and Dimitri Dimakopoulos. “The Canadian Architect Yearbook Award 1973. Jury comments.” The Canadian Architect Yearbook 1973: 24-57.
- Murray & Murray & Partners, Mathers & Haldenby with Dimitri Dimakopoulos & Partners. Rideau Street enclosure study Ottawa and Montreal: Consultant report, Sept. 1978. 56 pages.
- Musée d’art contemporain de Montréal. La petite histoire de la construction du Musée d’art contemporain de Montréal. Montreal: Musée d’art contemporain, 11 Jan. 1991. 2 pages.
- “Museums plans unveiled.” The Gazette 29 Nov. 1983: B-6.
- “National Arts Centre.” Architecture Canada May 1969: 29-52.
- “National Arts Centre, Ottawa.” The Canadian Architect July 1969: 30-63.
- National Capital Commission. Annual report 1977-1978 Ottawa-Hull: National Capital Commission, 1978: 77 pages.
- “National Gallery, Museum invites architects’ proposals.” The Gazette 8 Jan. 1983: F-8.
- Nichol, Arthur B. Former ARCOP associate. Answers to questionnaire written on 30 April 2000.
- “Norman Wade Building, Pointe Claire, P.Q.” The Canadian Architect July 1963: 41-5.
- Norwich, John Julius, General Editor. Great Architecture of the World. New York: Bo-

- nanza Books, 1978. 288 pages.
- “Nouveau musée.” Bâtiment Nov.- Dec. 1983: 16.
- “Odds and ends.” The Canadian Architect Dec. 1958: 10.
- “Odds and ends. Arts Centre.” The Canadian Architect Sep. 1965: 5
- “Opinion. Opposing Montreal’s super-project - Cité Concordia.” Architecture Canada Jul. 1970: 4-5.
- Ouellet, André, and C. M. Drury. Hull Centre-Ville. Ottawa-Hull: National Capital Commission: 1978: 23 pages.
- Ouellet, Jean. “Réplique. Le Palais de Justice de Québec.” Le Devoir 19 oct. 1979: 4.
- “Palais de Justice à Québec.” Le Devoir 22 Fev. 1979: 8.
- Palais de Justice de Québec. Concours d’architecture. Membres du comité de sélection des groupes professionnels. Annexe A. Quebec: Gouvernement du Québec; Ministère des Travaux publics et de l’Approvisionnement, 1979. 1 page.
- Palais de Justice de Québec. Concours de projet - première étape. Equipes retenues par le comité de sélection. Annexe B. Quebec: Gouvernement du Québec; Ministère des Travaux publics et de l’Approvisionnement, 1979. 3 pages.
- Pashalis, Sophie Phocas. Niece of Dimitri Dimakopoulos. Answers to questionnaire written on Jan. 7, 2000.
- Paul, Henri. “L’insonorisation de la Grande Salle.” Architecture - Bâtiment -Construction Jan. 1964: 29-30.
- “Perspective. Projects.” The Canadian Architect Aug. 1972: 6-7.
- Pevsner, Nikolaus. An Outline of European Architecture. Reprinted 7th Ed. London: Penguin Books, 1990. 496 pages.
- Picard, Geneviève. “En plein dans le 1000.” L’Actualité 15 May 1992: 46-48.
- Picard, Geneviève. “L’architecte le plus haut en ville.” L’Actualité 15 May 1992: 50-1.
- Pinker, Donovan. “Place Ville Marie. Planning.” Journal RAIC Feb. 1963: 75-6.
- Pitt, Françoise. “La Cité, C’est la formule de l’avenir.” Bâtiment June 1975: 7-8.
- “Place Bonaventure. Montréal.” Architecture - Bâtiment -Construction Dec. 1967: 13-30.
- “Place Bonaventure.” The Canadian Architect Sep. 1967: 41-66.
- “Place de la Justice, un défi pour le maître-d’oeuvre.” Journal Constructo 1st Nov.

- 1983: 20.
- “Place de la Justice.” Bâtiment Nov./Dec. 1983: 20-22.
- “Place des Arts.” The Montreal Star 17 Sep. 1963: Special Section 1-14.
- “Place des Arts.” The Gazette 21 Sep. 1963: 17-28.
- “Place des Arts.” Le Devoir 20 Sep. 1963: 10-5.
- “Place des Arts. Etudes d’ avant-projet pour un centre.” Architecture - Bâtiment - Construction Jan. 1959: 28-32.
- Place des Arts Montreal: Librairie Beauchemin Limitée, 1970. 22 pages.
- “Place Ville Marie.” Journal RAIC Feb. 1963: 45-87.
- “Place Ville Marie.” The Canadian Architect Feb. 1963: 53-88.
- “Place Ville Marie, Montreal.” The Canadian Architect Oct. 1962: 41-2.
- “Place Ville Marie opens Thursday September 13 at 4 P.M.” The Montreal Star 11 Sep. 1962: special section 1-28.
- “Place Ville Marie.” The Gazette 12 Sep. 1962: 21-32.
- “Place Ville Marie.” The Gazette 13 Sep. 1962
- “+15 Calgary. A development plan for downtown.” Architecture Canada Nov. 1969: 9-12.
- Poddubiuk, Mark. “Grave disappointments and unexpected pleasures. The new museums.” Architecture Québec ARQ Aug. 1992: 4,5,7.
- Pontbriand, Chantale. “Enjeux actuels du Musée d’art contemporain.” Parachute No. 45 Jan-Feb 1986-7: 42-44.
- Poulain, Yvan. “En réaménageant Hull, on a oublié l’aspect social.” La Presse 30 Nov. 1981.
- “Première phase du campus de l’UQAM: \$37 millions.” Bâtiment Jan. 1975: 7.
- Pressman, Norman. “Anatomy of the pedestrian mall.” The Canadian Architect March 1971: 49-55
- Prévost, Robert. “Le 1000 de La Gauchetière.” Actualité Immobilière Vol. XV No. 3 Autumn 1991: 36-46.
- Prévost, Roland. “Une université vraiment intégrée au milieu urbain.” Bâtiment Dec. 1973: 28-29.

- “Project: Canadian Centre for the Performing Arts, Ottawa.” The Canadian Architect Sep. 1964: 64-5.
- “Projects.” The Canadian Architect Aug. 1970: 8-9.
- “Projet de \$42 millions à Hull”. Bâtiment May 1973: 6.
- “Projets. Hôtel Concorde-Québec.” Architecture Concept July/Aug. 1972: 12.
- “Projet primé de la salle de concert de Vancouver.” Architecture - Bâtiment - Construction Aug. 1955: 30-2.
- Public Works Canada. Report on the development concept. Canal de Lachine. Montreal: Public Works Canada, 1977: 51 pages.
- “QE. The Queen Elizabeth Theatre.” The Canadian Architect Jan. 1960: 43-66.
- “Quebec invests in Bio-Mega project.” The Globe and Mail 13 Nov. 1984: B5.
- Ravensbergen, Jan. “4 Firms find a home at biotechnology institute.” The Gazette 3rd Dec. 1987: E-1.
- Ravensbergen, Jan. “Quebec seeking partners for its Laval pharmaceuticals company”. The Gazette 4 Dec. 1987.
- “Rectificatif...” Bâtiment Jan.-Feb. 1985: 8.
- “Regards. Projets. Hôtel Concorde-Québec.” Architecture Concept July-Aug. 1972: 12.
- “Regards. Projets. Hôtel Concorde Ouest.” Architecture Concept Jan./Feb. 1973: 8.
- “Regards. Projets. Hôtel, Cité Concordia.” Architecture Concept Jan./Feb. 1973: 8-9.
- Reid, Dennis. A concise history of Canadian painting. 2nd ed. Toronto: Oxford University Press Canada 1988, 418 pages.
- Rémillard, François and Brian Merrett. L’architecture de Montréal. Guide des styles et des bâtiments. Montréal: Editions du Méridien, 1990. 222 pages.
- Renaud, Daniel. “La SGF cède Bio-Méga au secteur privé.” Finance 15 Aug. 1988: 6.
- Renaud, George. “Les grands projets.” Bâtiment May-June 1989: 9.
- Renaud, George. “Montréal ... en pleine effervescence.” Bâtiment Sept.-Oct. 1988: 9.
- Répertoire d’architecture traditionnelle sur le territoire de la Communauté Urbaine de Montréal. Architecture commerciale I. Les banques. Montreal: Communauté Urbaine de Montréal, Service de la planification du territoire, 1980: 128-9.
- “Report: What’s happening to downtown Montreal.” The Canadian Architect April

1959: 66-71.

“Restaurant for Vistarchi Building Corporation, Dorval.” Journal RAIC June 1958: 237.

Revel, Jean-François et al. L'architecture du XXe siècle. Lauzanne: Julliard, 1964. 284 pages.

“Revêtement du cuivre. Palais de Justice de Québec.” Revue Cuivre Canadien No. 93 Summer 1983: 9-11.

Rioux, Daniel. “Le quadrilatère de la PdA est remis à la population.” Le Journal de Montréal 28 may 1993: 34.

Roberts, Suzanne, and André Poitras. La “Place de la Justice” ... confort assuré par des techniques sophistiquées! Telbec : Code 1, communiqué no 5. Quebec: Gouvernement du Québec; Ministère des Travaux publics et de l'Approvisionnement, 27 Oct. 1983. 2 pages.

Roberts, Suzanne, and André Poitras. La “Place de la Justice”... déjà quatre ans d'Histoire! Telbec: Code 1. Communiqué no 1. Quebec: Gouvernement du Québec; Ministère des Travaux publics et de l'Approvisionnement, 27 Oct. 1983. 5 pages.

Roberts, Suzanne, and André Poitras. La “Place de la Justice” ... quelques particularités architecturales. Telbec: No 1. Communiqué no 3. Quebec: Gouvernement du Québec; Ministère des Travaux publics et de l'Approvisionnement, 27 Oct. 1983. 2 pages.

Roberts, Suzanne, and André Poitras. La “Place de la Justice”... un défi relevé! Telbec - No 1. Communiqué no 4. Quebec: Gouvernement du Québec; Ministère des Travaux publics et de l'Approvisionnement, 27 Oct. 1983. 2 pages.

Roberts, Suzanne, and André Poitras. La “Place de la Justice”. Une réalisation tout à l'honneur des travailleurs du Québec. Telbec. Code 1. Quebec: Gouvernement du Québec; Ministère des Travaux publics et de l'Approvisionnement, 28 Oct. 1983. 2 pages.

Roberts, Suzanne, and André Poitras. La “Place de la Justice ”... un projet intégré au développement du Québec! Telbec. Code 1, Communiqué no 6. Quebec: Gouvernement du Québec; Ministère des Travaux publics et de l'Approvisionnement, 27 Oct. 1983. 2 pages.

- Roberts, Suzanne, and André Poitras. La "Place de la Justice" ... un projet réalisé à l'intérieur des coûts et des échéanciers prévus. Telbec: Code 1. Communiqué no 2. Quebec: Gouvernement du Québec; Ministère des Travaux publics et de l'Approvisionnement, 27 Oct. 1983. 3 pages.
- Rogatnik, Abraham. "Criticism" The Canadian Architect Jan. 1960: 63-6.
- "Royal Bank Plaza, Toronto." The Canadian Architect April 1977: 38-48.
- Sabbath, Lawrence. Spanking new home puts Musée on the map. Three-storey building is first art museum construction project since 1912." The Gazette 28 April 1984: A-13.
- Sauvé, Mathieu-Robert. "Théâtres sous surveillance." L'Actualité Vol.14 No. 6 June 1989: 152-4.
- Schoenauer, Norbert. Former McGill student and associated as consultant with ARCOP. Telephone conversation, 8 Dec. 1999.
- Schoenauer, Norbert. "Fathers of Confederation Memorial Buildings, Charlottetown. Design considerations." The Canadian Architect Nov. 1964: 42-3.
- Schoenauer, Norbert. "Place Ville Marie. Critique One." The Canadian Architect Feb. 1963: 55-7.
- Schulze, David. "Le Musée d'art contemporain. Mme Lise Bacon, ministre des affaires culturelles." Letter to La Presse 4 Dec. 1986: B2.
- Schupp, Patrick. "Pro-cathédrale St-George de la Communauté grecque de Montréal." Architecture - Bâtiment - Construction March 1962: 32-7.
- "Second-place architect sues over museum." The Gazette 30 May 1984: A-3.
- Shadbolt, Douglas. "Confederation Centre. An appraisal by Douglas Shadbolt MRAIC." Journal RAIC Dec. 1964: 24-36.
- Simpson, Kieran, Editor. Canadian Who's Who. Vol. 17. Toronto: University of Toronto Press, 1982.
- "Sites set for gallery and museum." The Globe and Mail 2 Oct. 1982: E-7.
- "6,000,000 \$ pour la Nouvelle Salle de Concert de l'UQAM." La Presse 2 Oct. 1990: B7.
- "Smart move, Montreal." News & views. Kone in-house magazine. No. 4 1992: 16-23.
- "Special issue. 25. 1955-1980." The Canadian Architect Nov. 1980: 16-49.

- Stankiewicz, Audrey. "Place Bonaventure: hotel interior." The Canadian Architect Sep. 1967: 65-6.
- Stenman, Hans. Former ARCOP and Dimitri's associate. Answers to questionnaire written on 30 April 2000.
- Stenman, Hans. Telephone conversations, 1st and 10 Nov. 2000.
- "Summerlea Golf & Country Club, Pointe Cascades, P.Q." The Canadian Architect Sep. 1963: 47-56.
- Sung, William. "Office towers can also be friendly." Architecture of Israël No. 17 January 1994: 22-33.
- "Supplément. La recherche industrielle. La part du Québec est meilleure qu'en recherche fondamentale." Finance Vol. No. 43 19 Aug. 1985: 23.
- Swartzman, Monte Theodore. McGill graduate in architecture, 1955. Telephone conversation, 17 Dec 1999.
- Théberge, Pierre, et al. L'architecture de Edward & W.S. Maxwell Montreal: Musée des Beaux-Arts, 1991: 191 pages.
- Thivierge, Marc. "L'incendie d' Alexis Nihon. Quand la cigale s'en tire aussi bien que la fourmi." Direction Informatique Vol. 2 No. 12 1st Sept. 1989: 15.
- "Toronto will have 6,000 new hotel rooms by mid-1972 - A 50% increase - But Montreal had its boom for Expo' 67." Canadian Building Sept. 1970: 32.
- "The 1974 Canadian Architect Yearbook Award of Excellence. Dimitri Dimakopoulos & associates and Jodoin Lamarre Pratte: Université du Québec à Montréal - Downtown Campus, Québec." The Canadian Architect Yearbook 1974: 36-7.
- "The 1974 Canadian Architect Yearbook Award of Excellence. Dimitri Dimakopoulos & associates: Winter Wondorlando, Orlando, Florida." The Canadian Architect Yearbook 1974: 34-5.
- "The initial phase of Cité Concordia..." Canadian Building Aug. 1970: 6.
- "The National Gallery of Canada, Ottawa." The Canadian Architect June 1988: 28-43.
- "The outstanding Canadians of 1964." Maclean's 2 Jan. 1965: 7-11.
- "The shopping promenade Place Ville Marie opens Thursday at 4:45." The Gazette 12 Sep. 1962: 37-44.

- “The shopping promenade Place Ville Marie opens today at 4:45.” The Gazette 13 Sep. 1962: 25-32.
- “To be Montreal’s tallest building ...” Canadian Building July-Aug. 1989: 5.
- “25. Special issue.” The Canadian Architect Nov. 1980: 16-49.
- “Un édifice dont Montréal sera fière.” Bâtiment Jan. 1973: 12-13.
- “Une nouvelle tour...” Bâtiment Nov.-Dec. 1984: 7.
- “Un évènement historique à la Banque Royale du Canada, Place Ville-Marie.” Le Devoir 12 Sep. 1962: 10.
- Université du Québec à Montréal. Construction de la phase II du campus. Montréal: UQAM, 1986. 20 pages.
- “Université du Québec à Montréal.” La brique d’argile au Canada Vol. 4 No. 2 June 1987: 8 pages.
- “Un Palais des congrès sortant de l’ordinaire conçu par une équipe du Québec.” Bâtiment Oct. 1978: 16-19.
- “UQAM. Planification.” Architecture Concept Jan./Feb. 1973: 20-22.
- “Urban renewal. The “reactionary nonsense” of cherishing old buildings.” Architecture Canada Jul. 1970: 1-2.
- “Urban renewal. Two Calgary projects move ahead.” Architecture Canada 16 Feb. 1970: 3.
- Utas, Gregory. “Evolving images in Ottawa.” Architecture Québec ARQ (April 1989): 23, 30-1.
- Valiquette, André. Inauguration du Pavillon Thérèse Casgrain, première étape de la phase II de construction du campus de l’UQAM. Montreal: service de l’information externe, UQAM, 1989. 2 pages.
- “Vancouver’s Civic Auditorium.”, The Canadian Architect, May 1956: 17-45.
- Vanlaethem, France, et al. “Ernest Cormier 1885-1980” Architecture Québec ARQ No. 53 (Feb. 1990): 7-29.
- Vanlaethem, France. “L’architecture n’a pas bonne presse.” Architecture Québec ARQ June 1988: 15-19.
- Vanlaethem, France. “Le campus de l’UQAM: prix d’excellence 1980 et pourquoi pas?”



- Architecture Québec ARQ Aug. 1986: 23.
- Vanlaethem, France. "Raymond T. Affleck. Un professionnel, au plein sens du terme." Architecture Québec ARQ No.34 Dec. 1986: 12-23.
- Varry, Jacques. "Place des Arts. La Grande Salle." Architecture - Bâtiment - Construction Jan. 1964: 16-23.
- Varry, Jacques. "Place Bonaventure. Montréal. Discussion." Architecture - Bâtiment - Construction Dec. 1967: 24-5.
- Vecsei, Eva. Former ARCOP and Dimitri's employee and associate. Telephone conversation, 7 Apr. 2000.
- Vecsei, Eva. Answers to questionnaire written on 30 April 2000.
- Viau, René. "Le nouveau Musée d'art contemporain." Vie des Arts Vol. XXIX No.116 Sept.-Oct. 1984: 66-7.
- Viau, René. "L'UQAM ... ou le bain de jouvence du quartier Saint-Jacques." Habitat Vol. 23 No.2 (1980): 10-17.
- Viau, René. "L'UQAM. Un campus greffé au centre-ville." Le Devoir 22 Sept. 1979 17.
- Viau, René. "L'UQAM, une université au coeur de la ville." Vie des Arts Vol. XXV No. 99 Summer 1980: 18-21.
- Viloria, James A., Place Bonaventure: process, form, and interpretation. M.A. Thesis. Montreal: Concordia University, 1994. 132 pages.
- Vleminckx, Marcl. "Place des Arts: splendeur et chahut. Le tout Montréal était là." Le Devoir 23 Sep. 1963: 1.
- Warshaw, Leonard D. McGill Graduate in architecture, 1955. Telephone conversation, 9 Dec. 1999.
- Wells, Paul. Dawson gets \$19 million to merge campuses." The Gazette 6 Aug. 1994: A 3.
- Wigglesworth, David. Former ARCOP employee and Dimitri's associate. Answers to questionnaire written on 30 April 2000.
- Wigglesworth, David. First interview in Montreal on Dec. 2nd, 2000.
- Wigglesworth, David. Second interview in Montreal on Dec.18, 2000.

Wigglesworth, David. Third interview in Montreal on Jan. 9, 2001.

Wigglesworth, David. Fourth interview in Montreal on Jan. 31, 2001.

Wigglesworth, David. Fifth interview in Montreal on Feb. 7, 2001.

Wigglesworth, David. Sixth interview in Montreal on Feb. 21, 2001.

Winter Wondorlando. Right in the center. Montreal: Jacques Guillon / Designers Inc.,  
1974: Promotional brochure.

Woodsworth, Dr. Patrick. Letter to whom it concerns. 29 Sept. 1994. 2 pages.

Zeckendorf, William. "Financing of Place Ville Marie." Journal RAIC Feb. 1963: 52-3.